



**RG-NPE**

**RGOS 10.3(4b7)**



RGOS®10.3(4b7)

- 
- 
- 

1.

//

3.



---

---



---

# 1

- 
- 
- 
- no default
- CLI
- 
- 
- CLI
- CLI

## 1.1

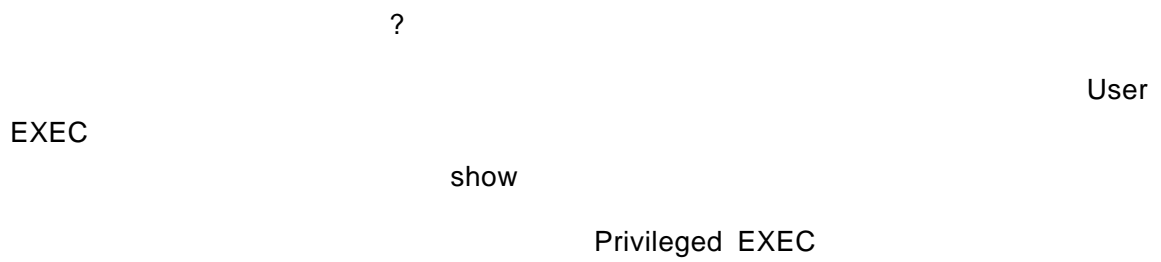

|                         |                               |                      |  |      |
|-------------------------|-------------------------------|----------------------|--|------|
|                         |                               |                      |  |      |
| User EXEC               |                               | Ruijie>              | <b>exit</b><br><b>enable</b>   |      |
| Privileged EXEC         | <b>enable</b>                 | Ruijie#              | <b>disable</b><br><b>configure</b>   |      |
| Global configuration    | <b>configure</b>              | Ruijie(config)#      | <b>exit</b> <b>end</b><br>Ctrl+C<br><b>interface</b><br><b>interface</b><br><br>VLAN<br><b>vlan</b> <i>vlan_id</i> |      |
| Interface configuration | <b>interface</b>              | Ruijie(config-if)#   | <b>end</b> Ctrl+C<br><br><b>exit</b><br><b>interface</b>   |      |
| Config-vlan<br>VLAN     | <b>vlan</b><br><i>vlan_id</i> | Ruijie(config-vlan)# | <b>end</b> Ctrl+C<br><br><b>exit</b>   | VLAN |

## 1.2

---

?

| <b>Help</b>                                 |  |
|---|--|
| <b>abbreviated-command-entry?</b>           | Ruijie# <b>di?</b><br>dir disable  |
| <b>abbreviated-command-entry&lt;Tab&gt;</b> | Ruijie# <b>show conf&lt;Tab&gt;</b><br>Ruijie# <b>show configuration</b>               |
| <b>?</b>                                    | Ruijie# <b>show ?</b>  |
| <b>command keyword ?</b>                    | Ruijie(config)# <b>snmp-server</b><br><b>community ?</b><br>WORD SNMP community string |

### 1.3

**show configuration**

Ruijie# **show conf**

### 1.4

**no default**

**no**

**no**

**no shutdown**

**shutdown**

**no**

---

default

default

default

no

default

no

default

## 1.5

## CLI

CLI

CLI

| % Ambiguous command: "show c"           |   |  |
|---|---|--|
| % Incomplete command.                   |   |  |
| % Invalid input detected at '^' marker. | ^ |  |

## 1.6

| Ctrl-P |        |
|--------|--------|
| Ctrl-N | Ctrl-P |

---

## 1.7

- 
- 

### 1.7.1

|  | Ctrl-B    |  |
|--|-----------|--|
|  | Ctrl-F    |  |
|  | Ctrl-A    |  |
|  | Ctrl-E    |  |
|  | Backspace |  |
|  | Delete    |  |
|  | Return    |  |
|  | Space     |  |

### 1.7.2

---



1)

**Show**

2)

**show**

| Ruijie# <b>show</b> <i>any-command</i>  <br><b>exclude</b> <i>regular-expression</i> | show |
|--|------|
| Ruijie# <b>show</b> <i>any-command</i>  <br><b>include</b> <i>regular-expression</i> | show |



**show**

"|"

## 1.9

"ip route 0.0.0.0 0.0.0.0 192.1.1.1"\_\_\_\_\_

"mygateway"

---

.....

\*

*\*command-alias=original-command*

EXEC "s" "show" "s?" 's'

Ruijie#**s?**

\*s=show show start-chat start-terminal-service

EXEC

"sv" "show version"

Ruijie#**s?**

\*s=show \*sv="show version" show start-chat  
start-terminal-service

Ruijie# **s?**

show start-chat start-terminal-service

"ia"

"ip address"

Ruijie(config-if)#**ia ?**

A.B.C.D IP address

dhcp IP Address via DHCP

Ruijie(config-if)#**ip address**

**"ip address"**

**show aliases**

## **1.9.1 CLI**

CLI

PC

CLI

Console

Outband

Telnet

---

# 2

## 2.1

Flash

---

```

USB          flash          USB
flash        512K
flash        flash          512M          4M
flash        flash
USB          flash          USB
flash        4M
flash        110%
          10MB          flash          10MB
          flash          11MB

```

---

## 2.2.2

| Ruijie# <b>cd</b> <i>directroy</i> | directory |
|------------------------------------|-----------|
| Ruijie# <b>cd</b> <i>../</i>       |           |
| Ruijie# <b>cd</b> <i>./</i>        |           |

MNT Document

Ruijie# **cd** *mnt/document*

MNT/Document

## 2.2.3

### copy

| Ruijie# <b>copy</b> <i>flash: filename flash: directoryname</i> |  |
|---|--|
| Ruijie# <b>copy</b> <i>flash: filename sour directoryname</i>   |  |



---

|                    |  |
|--------------------|--|
|                    |  |
| Ruijie# <b>pwd</b> |  |

## 2.2.8

|                             |  |
|-----------------------------|--|
|                             |  |
| Ruijie# <b>del filename</b> |  |

MNT

large.c

```
Ruijie# del mnt/large.c
```

## 2.2.9

|                                       |  |
|---------------------------------------|--|
|                                       |  |
| Red-Giant# <b>rmdir directoryname</b> |  |

MNT

```
Ruijie# rmdir mnt
```





tftp

**copy tftp://localtion/filename flash:filename [vrf vrfname]**

**copy tftp://localtion/filename flash:"filename" [vrf vrfname]**

---

### 3.2.2 XMODEM

CLI

Windows

Windows

“ ”

“ ”

”

1

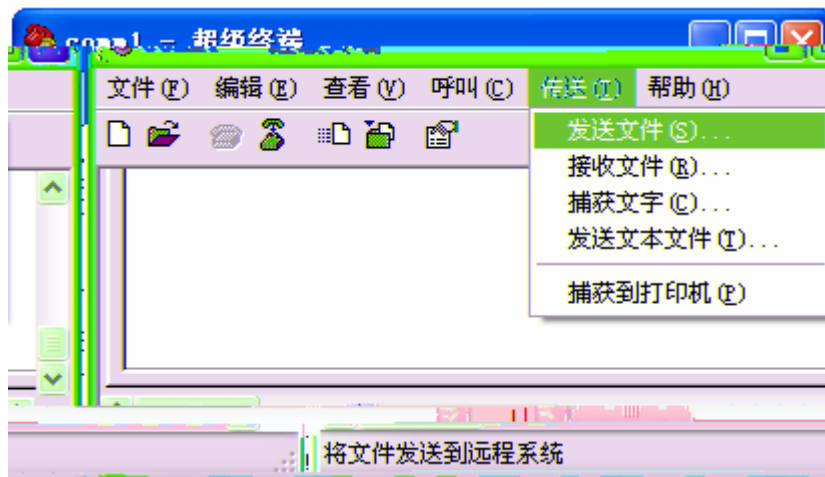

1

“Xmodem”

“ ”

Windows

2

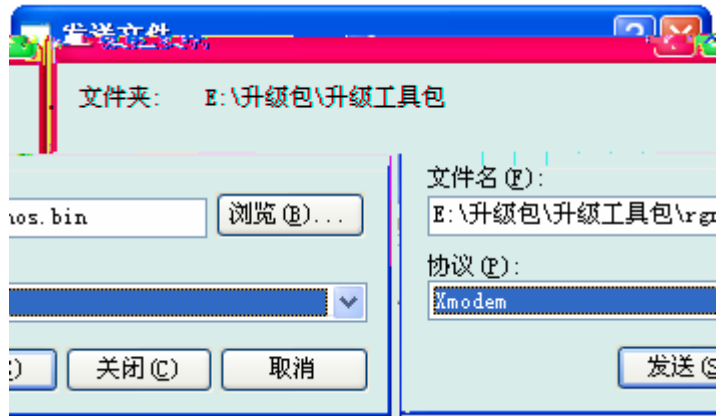

2

|   |                 |
|---|-----------------|
|   |                 |
| Ruijie# <b>copy xmodem flash:filename</b> | <i>filename</i> |

CLI

Windows

Windows

“ ” “

”

3

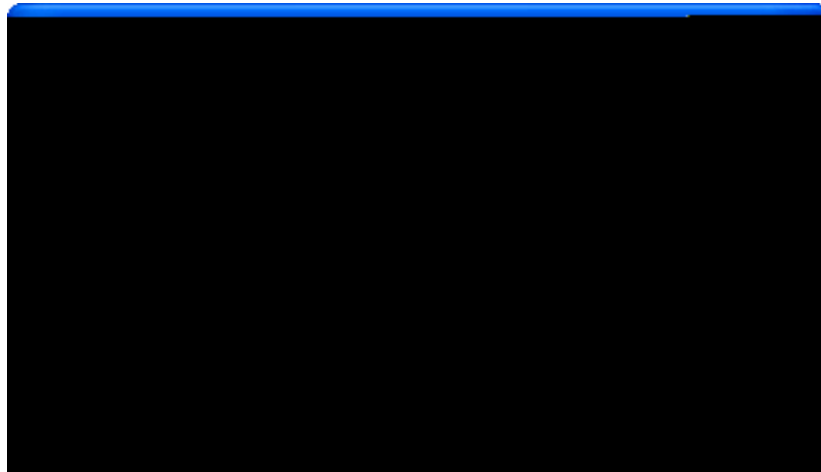

3

“Xmodem” “ ”

“ ”

4

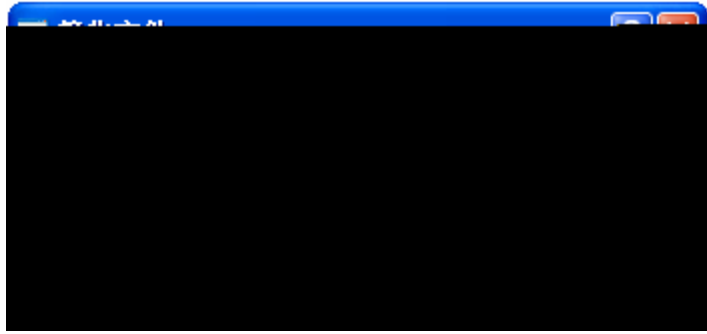

4



Ruijie# **copy flash:***filename* **xmodem**

*filename*

---

**show version**

**redundancy**

**force-switchover**

---

●

1 **rgos.bin**

2 **copy**

3

Upgrade Slave CM MAIN successful!!

Upgrade CM MAIN successful!!

1

2

Installing is in process .....

Do not restart your machine before finish !!!!!!

.....

3

Installing process finished .....

Restart machine operation is permitted now !!!!!!

4

System restarting, for reason 'Upgrade product !'.

5

5 6

7

System load main program from install package .....

6

A new card is found in slot [1].

System is doing version synchronization checking .....

Current software version in slot [1] is synchronous.

System needn't to do version synchronization for this card .....

---

System is doing version synchronization checking .....  
Card in slot [3] need to do version synchronization .....

Version synchronization began .....  
Keep power on, don't draw out the card and don't restart your machine  
before finished !!!!!!

Transmission is OK, now, card in slot [3] need restart ...  
Software installation of card in slot [3] is in process .....  
!!  
!!  
!!!!!!!!!!!!!!  
Software installation of card in slot [3] has finished  
successfully .....  
The version synchronization of card in slot [3] get finished  
successfully.



# 4 HTTP

## 4.1 HTTP

### 4.1.1 HTTP

HTTP HTTP HTTP  
HTTP  
- % " HTTP - % "

## 4.2

HTTP

|   |         |
|---|---------|
|   |         |
|   | 0.0.0.0 |
|   | 80      |
| 8 | 4AW!    |

```
Ruijie# http update web character-db // WEB
updating files, please wait...
update success!
```

### 4.3.2

HTTP 0.0.0.0 80

| Step 1 | Ruijie# <b>configure terminal</b>  |  |
|--------|--|--|
| Step 2 | Ruijie(config)# <b>http update server host</b><br>[ <b>port port-value</b> ] |  |
| Step 3 | Ruijie# <b>show running</b>  |  |



```
#
Ruijie# configure terminal
Enter configuration commands, one per line. End with CNTL/Z.
Ruijie(config)# http update server 10.83.132.1
Ruijie(config)# exit
```

## 4.4 HTTP

- \_\_\_\_\_

### 4.4.1

HTTP

|  |  |
|--|--|
|  |  |
|--|--|

## HTTP

---

|               |  |  |
|---------------|--|--|
| <b>Step 1</b> | Ruijie# <b>configure terminal</b>          |  |
| <b>Step 2</b> | Ruijie(config)# <b>http update set oob</b> |  |
| <b>Step 3</b> | Ruijie# <b>show running</b>                |  |

**no http update set oob**

# HTTP

Ruijie# **configure terminal**

Enter configuration commands, one per line. End with CNTL/Z.

Ruijie(config)# **http update set oob**

Ruijie(config)# **exit**



---

# 5

## 5.1

Ruijie

Dialer      NULL      Loopback

Ruijie

|          | GigabitEthernet<br>tenGigabitEthernet | IEEE802.3 RFC894 |
|----------|---------------------------------------|------------------|
| Dialer   | dialer                                | —                |
| Loopback | Loopback                              | —                |
| NULL     | NULL                                  | —                |
|          | GigabitEthernet<br>0/0.10( )          | —                |

## 5.2

### 5.2.1

| Ruijie(config)# <b>interface</b> <i>interface-type</i><br><i>interface-number</i>    |  |
|--|--|
| Ruijie(config)# <b>no interface</b> <i>interface-type</i><br><i>interface-number</i> |  |

0      0

---

## 5.2.2 IP

NULL IP IP

| Ruijie(config-if)# <b>ip address</b> <i>ip-address</i><br><i>ip-mask</i> |  |
|--|--|
| Ruijie(config-if)# <b>no ip address</b>                                  |  |

IP IP

## 5.2.3

| Ruijie(config-if)# <b>description</b><br><i>interface-description</i> | 80 |
|---|----|
| Ruijie(config-if)# <b>no description</b>                              |    |

## 5.2.4 MTU

MTU IP 64 65535

| Ruijie(config-if)# <b>mtu</b> <i>bytes</i> | MTU |
|--|-----|
| Ruijie(config-if)# <b>no mtu</b>           | MTU |

## 5.2.5 Bandwidth

BandWidth OSPF RSVP

---

| Ruijie(config-if)# <b>bandwidth</b> <i>kilobits</i> | Bandwidth |
|---|-----------|
| Ruijie(config-if)# <b>no bandwidth</b>              | Bandwidth |

## 5.2.6

Hold-Queue

| Ruijie(config-if)# <b>Hold-Queue</b><br><i>Length {in   out}</i> |  |
|--|--|
| Ruijie(config-if)# <b>no Hold-Queue</b>                          |  |

## 5.3

- 
- 
- 

### 5.3.1

| Ruijie# <b>Show interface</b><br><b>[GigabitEthernet]  ...</b> |  |
|--|--|

---

|  |                                |
|--|--------------------------------|
|  |                                |
| Ruijie# <b>Clear counters</b><br>[GigabitEthernet]...  | <b>show interface</b><br><br>0 |
| Ruijie# <b>Clear interface</b><br>[GigabitEthernet]... |                                |

**clear counter**

**show interface gigabitEthernet 1/0**

```
Ruijie# show interface gigabitEthernet 1/0
gigabitEthernet 1/0 is DOWN , line protocol is DOWN
Interface address is: 192.168.10.10/24
MTU 1500 bytes, BW 2000 Kbit
Keepalive interval is 10 sec , set
Carrier delay is 2 sec
RXload is 1 ,Txload is 1
Queueing strategy: WFQ
```

---

## 5.4.2

```
Ruijie(config)# Interface gigabitEthernet 0/0  
Ruijie(config-if)# shutdown
```

# 6 LAN

LAN(Local Area Network)

## 6.1

### 6.1.1

- 
- IP
- MAC

#### 6.1.1.1

| Ruijie(Config)# <b>Interface</b><br><b>GigabitEthernet</b> <i>interface-number</i> | (R26 R36 ) |
|--|------------|
| Ruijie(Config)# <b>Interface</b><br><b>Glgabithernet</b> <i>interface-number</i>   | (R37 )     |

#### 6.1.1.2 IP

IP

| Ruijie (Config-if)# <b>ip address</b><br><i>ip-address ip-mask</i> [ <b>secondary</b> ]    | IP |
|--|----|
| Ruijie (Config-if)# <b>no ip address</b><br><i>ip-address ip-mask</i> [ <b>secondary</b> ] | IP |

IP

Secondary

IP

IP

6.1.1.3



LAN

---

VLAN  
VLAN

VLAN

LAN

LAN  
LAN

VLAN  
LAN

VLAN

VLAN

Canonical Format Indicator C T-R

Priority P 12 8

VLAN VLAN

## 6.2.2 VLAN

VLAN

- VLAN
- IP
- Vlan LAN

### 6.2.2.1 VLAN

VLAN

|   |                |
|---|----------------|
|   |                |
| Ruijie(config)# <b>interface GigabitEthernet</b><br><i>Sub_interface_number</i> | 802.1Q         |
|   | 802.1Q         |
| Ruijie((config-subif))# <b>encapsulation dot1Q</b><br><i>VlanID</i>             | VLAN ID VLANID |

VLANID VLANID naJTJtive/C2\_0 1 Tf 0.045

|   |    |
|---|----|
| ●   | ●  |
| Ruijie((config-subif))# <b>ip address</b><br><i>ip-address mask</i> | IP |

802.1Q

IP

VLAN

VLAN

### 6.2.3 VLAN

VLAN

**debug show**

|   |      |
|---|------|
| ●   |      |
| Ruijie# <b>debug vlan</b>                   | vlan |
| Ruijie# <b>no debug vlan</b>                | vlan |
| Ruijie# <b>show vlans</b> [ <i>VlanID</i> ] | VLAN |
| Ruijie# <b>clear vlan</b> [ <i>VlanID</i> ] | VLAN |

### 6.2.4 VLAN

●

VLAN

VLAN

1. VLAN 192.168.0.0/24

VLAN 192.168.1.0/24

2.

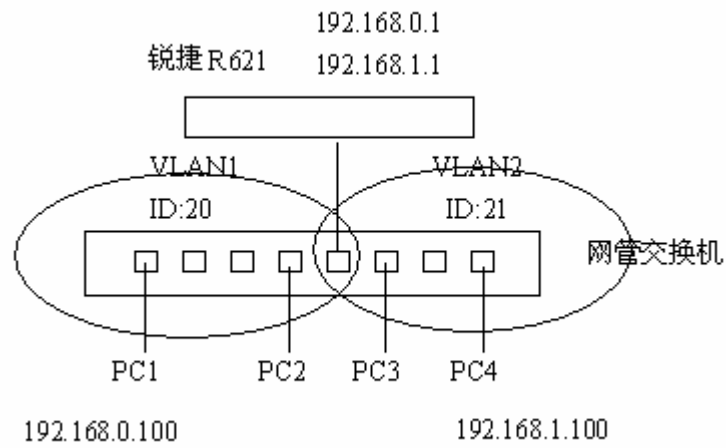

3

```
hostname "Ruijie"  
!  
interface gigabitEthernet 0/0
```

---

# 7

Dialer( ) Loopback( ) NULL( )

## 7.1 Loopback

Loopback( ) UP  
Loopback Loopback IP  
OSPF Telnet Telnet  
Loopback

| Ruijie(config)# <b>interface loopback</b><br><i>loopback-interface-number</i>              | loopback |
|--|----------|
| Ruijie(config)# <b>no interface</b><br><b>loopback</b><br><i>loopback-interface-number</i> | loopback |

**interface loopback** *loopback-interface-number*  
Loopback Loopback ( IP )

Loopback **no**  
**interface loopback** *loopback-interface-number* Loopback  
**show interfaces loopback** *loopback-interface-number* Loopback

| Ruijie# <b>show interfaces loopback</b><br><i>loopback-interface-number</i> | loopback |
|---|----------|

### show interfaces loopback

```
Ruijie# show interfaces loopback 0
Loopback 0 is UP , line protocol is UP
Hardware is Loopback
```

---

```

Interface address is: no ip address
MTU 1500 bytes, BW 8000000 Kbit
Encapsulation protocol is LOOPBACK, loopback not set
Keepalive interval is 0 sec , no set
Carrier delay is 2 sec
RXload is 1 ,Txload is 1
Queueing strategy: FIFO
Output queue 0/40, 0 drops;
Input queue 0/75, 0 drops
5 minutes input rate 0 bits/sec, 0 packets/sec
5 minutes output rate 0 bits/sec, 0 packets/sec
0 packets input, 0 bytes, 0 no buffer
Received 0 broadcasts, 0 runts, 0 giants
0 input errors, 0 CRC, 0 frame, 0 overrun, 0 abort
0 packets output, 0 bytes, 0 underruns
0 output errors, 0 collisions, 0 interface resets

```

```

          Loopback                               IP
          Bandwidth
MTU

```

## 7.2 NULL

```

          NULL( )
NULL( )      UP                               NULL
          NULL
NULL                                                help  exit
NULL
          NULL
Ruijie(config)#ip route 127.0.0.0 255.0.0.0 null 0
          NULL

```

|   |      |
|---|------|
|   |      |
| Ruijie(config)# <b>interface null 0</b> | NULL |

```

          NULL      " "                               no interface
null          NULL

```

## 7.3 Dialer

### 7.3.1 Dialer

```
Dialer
Dialer DDR( )
Dialer ( DDR)
```

### 7.3.2 Dialer

```
interface dialer Dialer
Dialer Dialer no interface
dialer Dialer Dialer
```

| Ruijie(config)# <b>interface dialer</b><br><i>dialer-number</i>    | Dialer |
|--|--------|
| Ruijie(config)# <b>no interface dialer</b><br><i>dialer-number</i> | Dialer |

### 7.3.3 Dialer

```
show interfaces dialer Dialer Dialer
Debug
```

| R2501+# <b>show interfaces dialer</b><br><i>dialer-number</i> | Dialer |
|---|--------|

#### show interfaces dialer

```
Ruijie# show interfaces dialer 1
dialer 1 is UP (spoofing) , line protocol is UP (spoofing)
Hardware is dialer
Interface address is: 192.168.20.1/24
MTU 1500 bytes, BW 56 Kbit
Encapsulation protocol is SLIP, loopback not set
Keepalive interval is 0 sec , set
Carrier delay is 2 sec
RXload is 1 ,Txload is 1
Queueing strategy: WFQ
```

---

5 minutes input rate 0 bits/sec, 0 packets/sec  
5 minutes output rate 0 bits/sec, 0 packets/sec  
0 packets input, 0 bytes, 0 no buffer  
Received 0 broadcasts, 0 runts, 0 giants  
0 input errors, 0 CRC, 0 frame, 0 overrun, 0 abort  
0 packets output, 0 bytes, 0 underruns  
0 output errors, 0 collisions, 0 interface resets

| MTU | Dialer<br>Bandwidth | IP |
|-----|---------------------|----|
|-----|---------------------|----|

## 7.4

### 7.4.1

1)

### 7.4.2

#### 7.4.2.1

•

#### 7.4.2.2

**interface gigabitEthernet**

**no interface gigabitEthernet**

IP



---

|   |  |
|---|--|
| Ruijie(config)# <b>interface gigabitEthernet</b><br><i>slot-number/interface-number.subinterface-number</i>               |  |
| Ruijie(config)# <b>no interface gigabitEthernet</b><br><i>slot-number</i><br><i>/interface-number.subinterface-number</i> |  |

Slot-number /Interface-number / Subinterface-number  
“ ”  
.

### 7.4.3

**show interfaces**

**debug**

---

# 8

## 8.1

### 8.1.1

interface

| Ruijie(config)# <b>interface</b> <i>ID</i> | interface<br>interface<br>range interface range macro |
|--|---|

Gigabitethernet 0/1

```
Ruijie(config)# interface gigabitethernet 0/1  
Ruijie(config-if)#
```

### 8.1.2 interface range

#### 8.1.2.1

interface range

interface range

|  |  |
|--|--|
|  |  |
|--|--|

---

|   |   |
|---|---|
| <p>Ruijie(config)# <b>interface range</b><br/>         {<i>port-range</i>   <b>macro</b> <i>macro_name</i>}</p> | <p><b>interface range</b></p> <p>macro</p> <p>,</p> |
|---|---|

**interface range**

range

**vlan** *vlan-ID - vlan-ID*, VLAN ID 1 4094

**GigabitEthernet** *slot*{ *port*} - { *port*}

**GigabitEthernet** *slot*{ *port*} - { *port*}

**TenGigabitEthernet** *slot*{ *port*} - { *port*}

|   |                        |
|---|------------------------|
| Ruijie(config)# <b>define interface-range</b> <i>macro_name interface-range</i> | macro_name 32          |
| Ruijie(config)# <b>interface range</b> <i>macro macro_name</i>                  | <b>interface range</b> |

**no define interface-range macro\_name**

**define interface-range**

- **vlan** *vlan-ID - vlan-ID*, VLAN ID 1 4094
- **GigabitEthernet** *slot/{ port} - { port}*
- **gigabitethernet** *slot/{ port} - { port}*

**interface range**

**define interface-range** GigabitEthernet1/1-4

```
Ruijie# configure terminal
Ruijie(config)# define interface-range resource
GigabitEthernet 1/1-4
Ruijie(config)# end T3 1 Tf 0.0228 Tc -2.08 -2.2 Td [(R)6(uiji)6(e# )]TJ /TT4 1 Tf 4.966 0 Td [(c
```

---

ports1to2N5to7

```
Ruijie# configure terminal
Ruijie(config)# no define interface-range ports1to2N5to7
Ruijie# end
```

### 8.1.3

| Ruijie(config-if)# <b>medium-type { fiber   copper }</b> |  |
|--|--|

Gigabitethernet 0/1

```
Ruijie# config terminal
Enter configuration commands, one per line. End with CNTL/Z.
Ruijie(config)# interface gigabitethernet 0/1
Ruijie(config-if)# medium-type fiber
Ruijie(config-if)# end
```

### 8.1.4

(Description)  
Gigabitethernet 1/1            A  
" Port for User A"

| Ruijie(config-if)# <b>description string</b> | 32 |
|--|----|

Gigabitethernet 0/1

```
Ruijie# config terminal
Enter configuration commands, one per line. End with CNTL/Z.
Ruijie(config)# interface gigabitethernet 0/1
Ruijie(config-if)# description PortForUser A
```

---

```

Ruijie(config-if)# speed 1000
Ruijie(config-if)# duplex full
Ruijie(config-if)# flowcontrol off
Ruijie(config-if)# end

```

---

|      |        |       |    |
|------|--------|-------|----|
| IEEE | Master | Slave | .. |
|------|--------|-------|----|

---

## 8.1.6 MTU

```

jumbo MTU
MTU
MTU MTU
MTU 64-1500 4 1500
SVI MTU

```

|                            |                      |
|----------------------------|----------------------|
|                            |                      |
| Ruijie(config-if)# Mtu num | MTU<br>Num <64-1500> |

Gigabitethernet 0/1 MTU

```

Ruijie# config terminal
Enter configuration commands, one per line. End with CNTL/Z.
Ruijie(config)# interface gigabitethernet 0/1
Ruijie(config-if)# mtu 64
Ruijie(config-if)# end

```

## 8.2

**show**

|  |  |
|--|--|
|  |  |
|--|--|

|  |      |
|--|------|
| Ruijie# <b>show interfaces</b><br>[ <i>interface-id</i> ]                    |      |
| Ruijie# <b>show interfaces</b><br><i>interface-id</i> <b>status</b>          |      |
| Ruijie# <b>show interfaces</b><br>[ <i>interface-id</i> ] <b>description</b> |      |
| <b>Interfaces</b><br><b>Counters</b>   | 0.5% |

8.3 LinkTrap0.M(0.J []0 d Tf0.0132 Tc 03.0073 503 -20

---

# 9

## 9.1

### 9.1.1

NPE



### 9.1.2.2

- ◇ Forward      forward
- ◇ Sniffer      sniffer
- ◇ Bypass      bypass

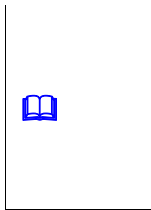

### 9.1.2.3

NPE

MGMT

---

|  |  |
|--|--|
|  |  |
|  |  |



---

**Step 2**

|  |  |
|--|--|
| Ruijie(config)# <b>specify interface</b><br><i>interface-name { lan   wan}</i> | <i>interface-name</i><br><i>lan</i><br><i>wan:</i> |
|--|--|

**Step 4**Ruijie(config-if)#**end****Step 5**Ruijie# **show running**

---

|   |      |
|---|------|
|  | show |
| sys-mode  |      |

---

1 GigabitEthernet 0/0

```
Ruijie(config)#sperranethe8 4r38 4eTf8 4/00CCcla38 4 10.02 0 3.427 10.02 30.terlG
Ruijie(config)#sperranethe8 4r38 4eTf8 4/00CCcwa38 4 10.02 0 3.427 10.02 30.terlG!5BGigabi
```

|   |                     |                 |   |      |
|---|---------------------|-----------------|---|------|
|  | 8                   | 4               | 1 | show |
|   | run xau-mode slot 0 | xau-mode slot 1 |   |      |
|   | 8                   | 2               |   |      |

```

1      4      1
Ruijie(config)#xau-mode slot 0
Please save the config, and reload NPE60 to take effect!
2      4      1
Ruijie(config)#no xau-mode slot 0
Please save the config, and reload NPE60 to take effect!

```

|   |           |            |
|---|-----------|------------|
|  | 10.3(4b7) | NPE60 V1.0 |
|   |           |            |

## 9.4

|  |  |
|--|--|
|  |  |
| Ruijie# <b>show bridge-map</b> [ <i>bridge-num</i> ] |  |
| Ruijie# <b>show sys-mode</b>                         |  |

1

---

LAN: GigabitEthernet 0/0 GigabitEthernet 0/3 GigabitEthernet 0/5  
WAN: GigabitEthernet 0/1 GigabitEthernet 0/2 GigabitEthernet 0/4

---

# 10

## 10.1

### 10.1.1

® NPE40 NPE60

Console

" "

MGMT Management

MGMT

### 10.1.2

MGMT

Console

MGMT  
MGMT

100M vs 115200bps

MGMT

1 MGMT

Telnet

2 MGMT

TCP/IPv4

Ethernet II

3

MGMT

IP

## 10.2

MGMT

|        |        |
|--------|--------|
|        |        |
| ip ref | enable |

|             |        |
|-------------|--------|
| duplex      | auto   |
| speed       | auto   |
| flowcontrol | enable |

## 10.3 MGMT

- \_\_\_\_\_ MGMT IP \_\_\_\_\_
- \_\_\_\_\_ MGMT \_\_\_\_\_
- \_\_\_\_\_
- \_\_\_\_\_

### 10.3.1 MGMT IP

MGMT                  IP                  MGMT                  IP

|               |  |    |
|---------------|--|----|
|               |  |    |
| <b>Step 1</b> | Ruijie# <b>configure terminal</b>  |    |
| <b>Step 2</b> | Ruijie(config)# <b>interface mgmt 0</b>                                      |    |
| <b>Step 3</b> | Ruijie(config-if-Mgmt 0)# <b>ip address</b><br><i>ip-address subnet-mask</i> | IP |

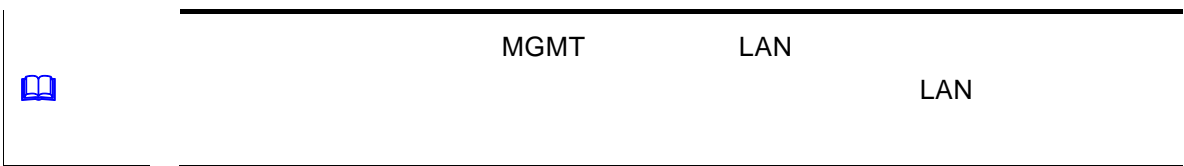

```
# MGMT IP
Ruijie#configure terminal
Enter configuration commands, one per line. End with CNTL/Z.
Ruijie(config)#interface mgmt 0
Ruijie(config-if-Mgmt 0)#ip address 192.168.1.1 255.255.255.0
```

---

## 10.3.2 MGMT

| <b>Step 1</b> | Ruijie# <b>configure terminal</b>                               |             |
|---------------|---|-------------|
| <b>Step 2</b> | Ruijie(config)# <b>interface mgmt 0</b>                         |             |
| <b>Step 3</b> | Ruijie(config-if-Mgmt 0)# <b>gateway A.B.C.D</b>                |             |
| <b>Step 4</b> | Ruijie(config-if-Mgmt 0)# <b>mtu mtu-value</b>                  | MTU         |
| <b>Step 5</b> | Ruijie(config-if-Mgmt 0)# <b>speed {10   100   1000   auto}</b> | speed auto  |
| <b>Step 6</b> | Ruijie(config-if-Mgmt 0)# <b>duplex { full   half   auto }</b>  | duplex auto |
| <b>Step 7</b> | Ruijie(config-if-Mgmt 0)# <b>flowcontrol</b>                    | enable      |
| <b>Step 8</b> | Ruijie(config-if-Mgmt 0)# <b>description text</b>               |             |
| <b>Step 9</b> | Ruijie(config-if-Mgmt 0)# <b>shutdown</b>                       | MGMT        |

---

- **ping oob**

|                              |                   |
|------------------------------|-------------------|
|                              |                   |
| Ruijie# <b>ping oob</b> host | ICMP echo request |

```
#          MGMT          192.168.1.2
Ruijie# ping oob 192.168.1.2
Sending 5, 100-byte ICMP Echos to 192.168.1.2, timeout is 2 seconds:
!!!!!!
Success rate is 100 percent, round-trip min/avg/max = 4/4/4 ms
```

- **tracert oob**

|                                 |  |
|---------------------------------|--|
|                                 |  |
| Ruijie# <b>tracert oob</b> host |  |



# 11 LINE

## 11.1

LINE

- LINE
- / LINE VTY
- LINE

## 11.2 LINE

### 11.2.1 LINE

LINE

LINE

LINE

LINE



Ruijie(config)# **line** [aux | console | tty | vty]

~~rsyTf0.04 TTc0 Tr 2.060213 Tc 0.570 Td[tt)6y)8(JTJTTO 1 Tf0.0202 Tc 1.570 Td(1g14 TE13 Tc 0.5Z~~

| VTY  | TTY  |
|--|------|
| <b>configure terminal</b>                          |      |
| <b>Line vty</b> <i>line number</i>                 | Line |
| <b>transport input</b> {all   ssh   telnet   none} | Line |
| <b>no transport input</b>                          | LINE |
| <b>default transport input</b>                     | LINE |

### 11.2.4 Line

LINE

Line

|  |      |
|--|------|
| <b>configure terminal</b>                                  |      |
| <b>Line vty</b> <i>line number</i>                         | Line |
| <b>access-class</b> <i>access-list-number</i> {in   out}   | Line |
| <b>no access-class</b> <i>access-list-number</i> {in  out} | Line |

---

# 12

## 12.1

DLDP

DLDP

mac

mac  
mac

arp

UP

ICMP echo  
echo

DLDP

/  
icmp echo

arp icmp echo  
dldp

## 12.2

### 12.2.1

- 
- ip
- interval

- retry

## 12.2.2

|   |  |
|---|--|
|   |  |
| Ruijie(config-if)# <b>lldp ip [nexthopip]</b> |  |



- 1) ICMP ECHO ICMP
- 2) up
- 3) down
- 4) ip

## 12.2.3 interval

|  |  |
|--|--|
|  |  |
| Ruijie(config-if)# <b>lldp ip interval val</b> |  |

## 12.3 retry

|   |  |
|---|--|
|   |  |
| Ruijie(config-if)# <b>lldp ip retry val</b> |  |

## 12.4 /

|  |  |
|--|--|
|  |  |
| Ruijie(config-if)# <b>lldp passive</b> |  |

---

# 13

## 13.1 PPPOE

### 13.1.1 PPPOE

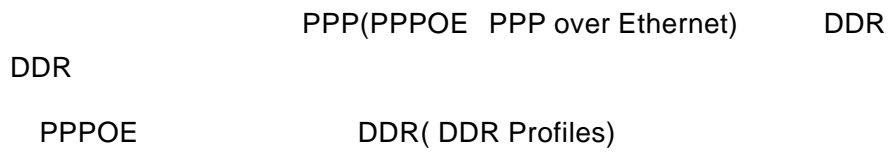

### 13.1.2 PPPOE



#### 13.1.2.1

- PPPOE
- 

**no shutdown**

PPPOE

|  |       |
|--|-------|
|  |       |
| Ruijie(config-if)# <b>pppoe enable</b> | PPPOE |

PPPOE      DDR Profiles  
DDR Profiles



|   |                   |
|---|-------------------|
| Ruijie(config-if)# <b>pppoe-client dial-pool-number</b> <i>pool-number</i><br><b>dial-on-demand</b> | (<br>,<br>) pppoe |
|---|-------------------|

|  |                        |
|--|------------------------|
| Ruijie(config-if)# <b>pppoe-client dial-pool-number</b> <i>pool-number</i> <b>no-ddr</b> | ,<br>(<br>,<br>) pppoe |
|--|------------------------|

---

|                |        |     |                |           |
|----------------|--------|-----|----------------|-----------|
| dial-on-demand | no-ddr | DDR | dial-on-demand | PPPOE DDR |
| no-ddr         | pppoe  | ,   | pppoe          | .         |

---

### 13.1.2.2

PPPOE          PPP          PPPOE

|   |                  |
|---|------------------|
| Ruijie(config)# <b>interface dialer</b> <i>dialer-number</i>      |                  |
| Ruijie(config-if)# <b>ip address negotiate</b>                    |                  |
| Ruijie(config-if)# <b>dialer pool</b> <i>pool-number</i>          |                  |
| Ruijie(config-if)# <b>dialer idle-timeout</b> <i>seconds</i>      |                  |
| Ruijie(config-if)# <b>encapsulation ppp</b>                       | PPP PPPOE<br>PPP |
| Ruijie(config-if)# <b>mtu</b> <i>1488</i>                         | 1488             |
| Ruijie(config-if)# <b>dialer-group</b> <i>dialer-group-number</i> | dialer-list      |

---

|  |  |
|--|--|
| Ruijie(config-if)# <b>ppp pap sent-username</b><br><i>username password password</i> |  |
|--|--|



1488

MTU

PPPoE

IP

**clear pppoe tunnel**

PPPoE

### 13.1.2.3

PPPOE

- 
- 

PPPOE

NAT



### 13.1.3 PPPOE

PPPOE, EXEC

| Ruijie# <b>show pppoe</b> { <b>tunnel   session</b> }             | tunnel session |
|---|----------------|
| Ruijie# <b>show interfaces dialer</b> <i>dialer-number</i>        | IP             |
| Ruijie# <b>debug pppoe</b> { <b>datas errors events packets</b> } | PPPOE          |

### 13.1.4 PPPOE

- 

PPPOE

1. 5 5
2. pppoe pppoe
3. NAT 192.168.0.0/24

- 

```

!
hostname "Ruijie"
!
ip subnet-zero

# PPPOE, 10
interface GigabitEthernet0/0
no ip address
duplex auto
pppoe enable
pppoe-client dial-pool-number 10 dial-on-demand

```

---

```

#
interface GigabitEthernet0/1
ip address 192.168.0.1 255.255.255.0
ip nat inside
ip mtu 1488
duplex auto
speed auto

#
interface Dialer1
ip address negotiate
mtu 1488
encapsulation ppp
ip nat outside
dialer pool 10 // 10
dialer-group 1
dialer idle-timeout 300 //5
ppp pap sent-username pppoe password 0 pppoe
!
ip nat inside source list 1 interface Dialer1
3CT*m4alet(1 )6plertarn
ip(ro)6(nte)6 100.0(0.)6( Dd)6(ia)6(le(1 1096( )]TJ0.017 Tc 0 -1.543 TD(! )T

!

```

IP

# 14 IP

## 14.1 IP

### 14.1.1 IP

|    |    |    |       |       |                 |
|----|----|----|-------|-------|-----------------|
| IP | 32 |    |       |       |                 |
|    |    | 8  | 0~255 | " . " | " 192.168.1.1 " |
|    |    | IP |       |       |                 |
| IP |    |    | IP    | 32    |                 |



" 1111"

E

IP

IP

IP

IP

|   |                             |     |   |
|---|-----------------------------|-----|---|
| B | 172.16.0.0~172.31.255.255   | 16  | B |
| C | 192.168.0.0~192.168.255.255 | 256 | C |

IP      TCP/UDP

RFC 1166

## 14.1.2 IP

IP

- IP
- ARP
- IP ..ip! @Gp%Ä"lrC—pG!5BQG!5D&'4K'LÄ

IP

14.1.2.2

ARP

IP

1

MAC

MAC

MAC

IP

2

IP

14.1.2.2.2 ARP

ARP                      Ethernet II                      ARPA

14.1.2.2.3 ARP

ARP    IP              MAC  
 ARP    ARP  
    ARP

ARP

| Ruijie(config-if)# <b>arp timeout seconds</b> | ARP<br>0-2147483      0 |
|---|-------------------------|
| Ruijie(config-if)# <b>no arp timeout</b>      |                         |

3600      1

14.1.2.3      IP

IP    IP  
 IP  
 IP

| Ruijie(config)# <b>no ip routing</b> | IP |
|--------------------------------------|----|
| Ruijie(config)# <b>ip routing</b>    | IP |

14.1.2.4

1  
 " 1"

IP

| Ruijie(config-if)# <b>ip broadcast-address</b> <i>ip-address</i> |  |
|--|--|
| Ruijie(config-if)# <b>no ip broadcast-address</b>                |  |

### 14.1.3 IP

- 
- 

#### 14.1.3.1

- 1) ARP
- 2) IP
- 3)

| Ruijie# <b>clear arp-cache</b>                                      | ARP |
|---|-----|
| Ruijie# <b>clear ip route</b> { <i>network</i> [ <i>mask</i> ]   *} | IP  |

|  |    |
|--|----|
| Ruijie# <b>show ip interface</b> [ <i>interface-type interface-number</i> ]                                      | IP |
| Ruijie# <b>show ip route</b> [ <i>network [mask]</i> ]   |    |
| Ruijie# <b>show ip route</b>   |    |
| Ruijie# <b>ping</b> <i>ip-address</i> [ <b>length bytes</b> ] [ <b>ntimes times</b> ] [ <b>timeout seconds</b> ] |    |

### 14.1.4 IP

IP

- IP

#### 14.1.4.1 IP

- 

IP

1



1 IP

RIP  
172.16.2.0/24

D

RIPv1  
172.16.1.0/24

C

- 

RIPv1  
172.16.2.0/24

C

192.168.12.0/24

172.16.1.0/24

C

D

RIP

A

B

192.168.12.0/24

172.16.3.0/24

A

B

A

```

interface GigabitEthernet 0/0
ip address 172.16.3.1 255.255.255.0 secondary
ip address 192.168.12.1 255.255.255.0
!
interface GigabitEthernet 0/1
ip address 172.16.1.1 255.255.255.0
!
router rip
network 172.16.0.0
network 192.168.12.0

```

B :

```

interface GigabitEthernet 0/0
ip address 172.16.3.2 255.255.255.0 secondary
ip address 192.168.12.2 255.255.255.0
!
interface GigabitEthernet 0/1
ip address 172.16.2.1 255.255.255.0
!
router rip
network 172.16.0.0
network 192.168.12.0

```

## 14.2 IP

### 14.2.1 IP

IP

- IP

### 14.2.2 IP

IP

IP ICMP  
ICMP

ICMP

RFC 792

IP

- ICMP
- ICMP
- ICMP
- IP MTU
- IP

14.2.2.1 ICMP

IP

14.2.2.3 ICMP

ICMP ICMP ICMP  
 ICMP ICMP  
 ICMP

|  |  |
|--|--|
|  |  |
| Ruijie(config-if)# <b>ip mask-reply</b>    |  |
| Ruijie(config-if)# <b>no ip mask-reply</b> |  |

14.2.2.4 IP MTU

MTU MTU  
 MTU MTU IP MTU IP MTU  
 MTU IP MTU MTU  
 MTU  
 IP MTU

|  |             |
|--|-------------|
|  |             |
| Ruijie(config-if)# <b>ip mtu bytes</b> | MTU 68~1500 |
| Ruijie(config-if)# <b>no ip mtu</b>    |             |

14.2.2.5 IP

IP IP IP  
 RFC 791  
 ICMP IP  
 IP

|  |  |
|--|--|
|  |  |
|--|--|

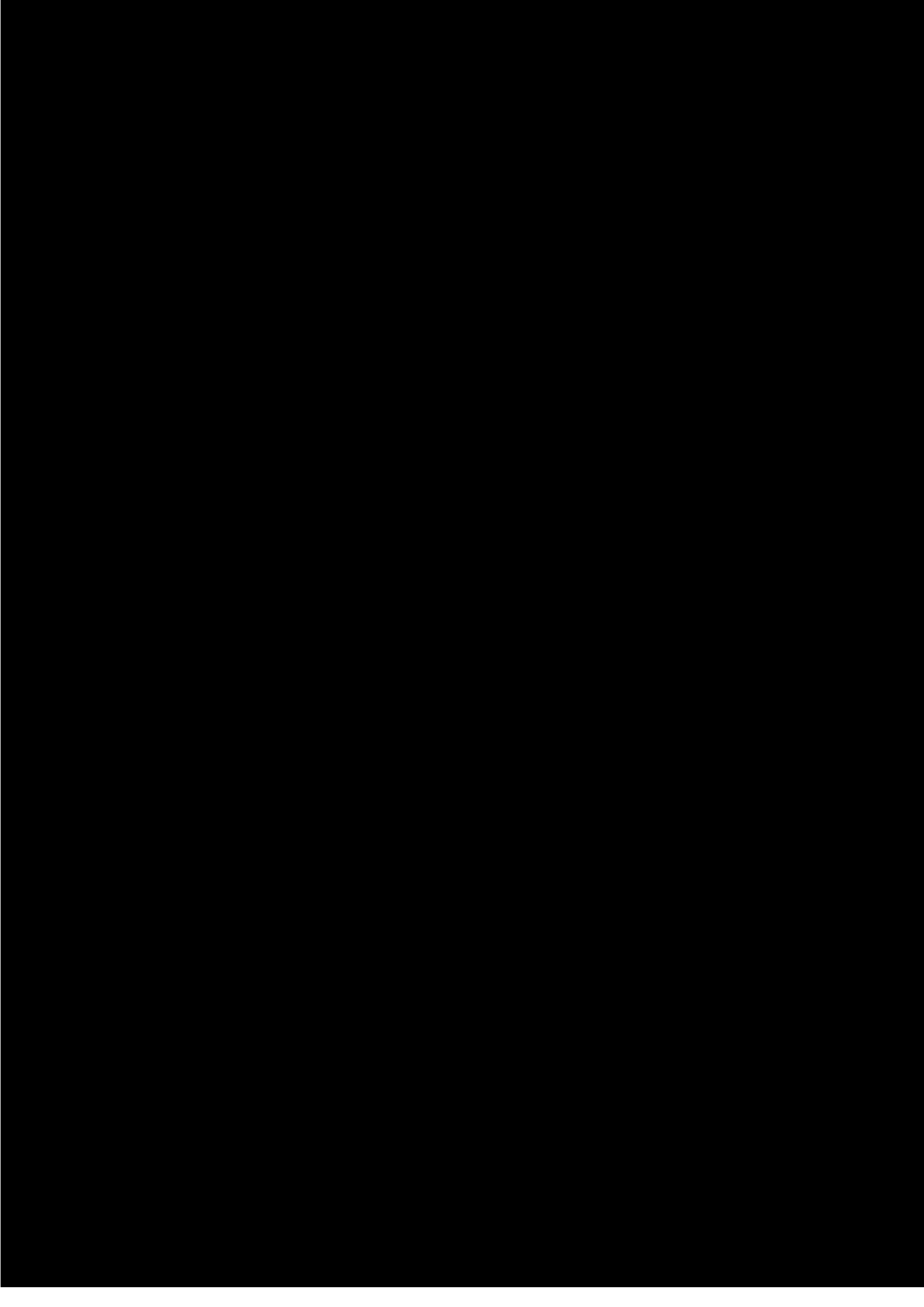

# 15 IPv4

## 15.1 IPv4

### 15.1.1 IPv4

Forwarding REF (Prefix Tree+Adjacency) Ruijie Express  
REF REF  
Cache CPU Cache  
CPU

REF

- Prefix Tree

Prefix Tree  
M-Tries Tree  
Radix Tree

IP

Radix Tree  
M-Tries Tree Prefix Tree  
Prefix

- Adjacency

REF

- 1) REF
- 2) Prefix Tree
- 3)

## 15.2

NPE

## 15.3

|    |    | IP/MASK |    | IP |    | REF |
|----|----|---------|----|----|----|-----|
|    |    |         |    |    |    |     |
|    | IP |         |    |    |    |     |
| 1. | IP | IP      |    |    |    | IP  |
|    |    |         |    |    |    |     |
| 2. | IP | IP      | IP |    | IP | IP  |
|    |    |         |    |    |    |     |
| 3. | IP | IP      |    | IP |    |     |
|    |    |         | IP |    |    |     |

REF

|   |       |
|---|-------|
|   |       |
| Ruijie# <b>show ip ref packet-statistic</b> [clear] | / REF |

### 15.4.2

|  |    |
|--|----|
|  |    |
| Ruijie# <b>show ip ref adjacency</b> [glean   local   ip   (interface <i>interface_type</i> <i>interface_number</i> )   <b>statistic</b> ] | IP |

### 15.4.3

IP

IP

IP

IP

IP

CPU

|   |  |
|---|--|
|   |  |
| Ruijie# <b>show ip ref exact-route</b> [vrf <i>vrf_name</i> ] source-ipaddress dest_ipaddress |  |

### 15.4.4

|  |   |
|--|---|
|  |   |
| Ruijie# <b>show ip ref route</b> [vrf <i>vrf_name</i> ] [default   ( <i>ip mask</i> )   <b>statistic</b> ] | 0 |

# 16 NAT

## 16.1 NAT

NAT( )

- NAT
- NAPT
- NAT
- TCP
- NAT
- NAT
- NAT

### 16.1.1 NAT

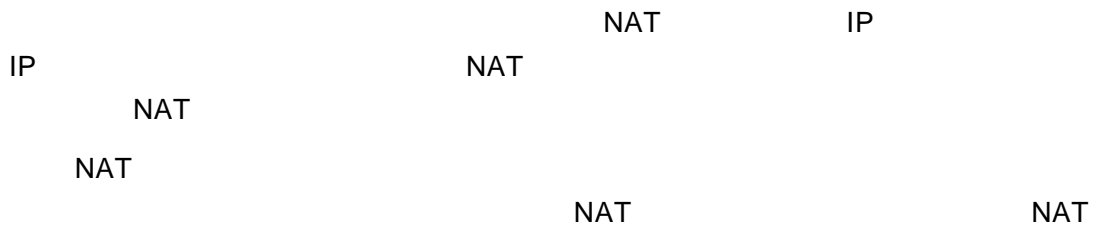

Inside outside

NAT

NAT

| <b>Step 1</b> | Ruijie(config)# <b>ip nat pool</b> <i>address-pool</i><br><i>start-address end-address {netmask mask  <br/>prefix-length prefix-length}</i> | IP |
|---------------|---|----|
| <b>Step 2</b> | Ruijie(config)# <b>access-list</b><br><i>access-list-number</i><br><b>permit</b> <i>ip-address wildcard</i>                                 |    |
| <b>Step 3</b> | Ruijie(config)# <b>ip nat inside source list</b><br><i>access-list-number pool address-pool [vrf</i><br><i>vrf_name]</i>                    |    |
| <b>Step 4</b> | Ruijie(config)# <b>interface</b> <i>interface-type</i><br><i>interface-number</i>   |    |
| <b>Step 5</b> | Ruijie(config-if)# <b>ip nat inside</b>   |    |
| <b>Step 6</b> | Ruijie(config)# <b>interface</b> <i>interface-type</i><br><i>interface-number</i>   |    |
| <b>Step 7</b> | Ruijie(config-if)# <b>ip nat outside</b>  |    |



### 16.1.2

### NAPT

NAT

NAPT( )

NAPT

NAPT

NAPT

NAPT



**Step 1** Ruijie(config)# **ip nat inside source static**  
**{UDP | TCP}** *local-address port*  
*global-address*  
*port* [**permit-inside**] [**vrf** *vrf\_name*]

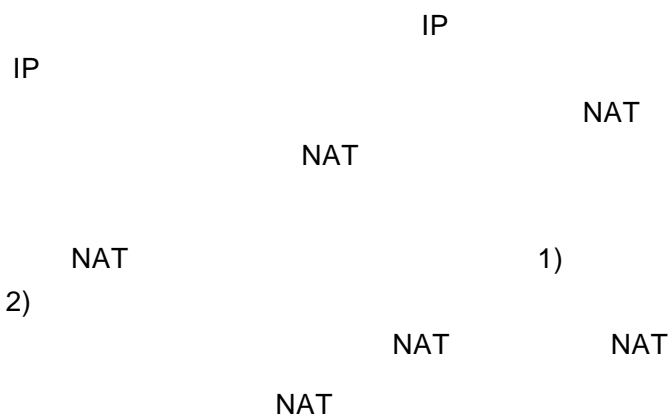

| <b>Step 1</b> | Ruijie(config)# <b>ip nat outside source static</b><br><i>global-address local-address [vrf vrf_name]</i> |  |
|---------------|---|--|
| <b>Step 2</b> | Ruijie(config)# <b>interface</b> <i>interface-type</i><br><i>interface-number</i>                         |  |
| <b>Step 3</b> | Ruijie(config-if)# <b>ip nat inside</b>   |  |
| <b>Step 4</b> | Ruijie(config)# <b>interface</b> <i>interface-type</i><br><i>interface-number</i>                         |  |
| <b>Step 5</b> | Ruijie(config-if)# <b>ip nat outside</b>  |  |

### 16.1.4 TCP



|  | Ruijie(config)# <b>ip nat pool</b> <i>address-pool</i><br><i>start-address end-address {netmask mask  </i><br><b>prefix-length</b> <i>prefix-length}</i> | IP          |
|--|--|-------------|
|  | Ruijie(config)# <b>access-list</b><br><i>access-list-number</i><br><i>permit ip-address wildcard</i>   | IP      ACL |
|  | Ruijie(config)# <b>ip nat inside destination list</b><br><i>access-list-number</i> <b>pool</b> <i>address-pool [vrf</i><br><i>vrf_name]</i>              |             |

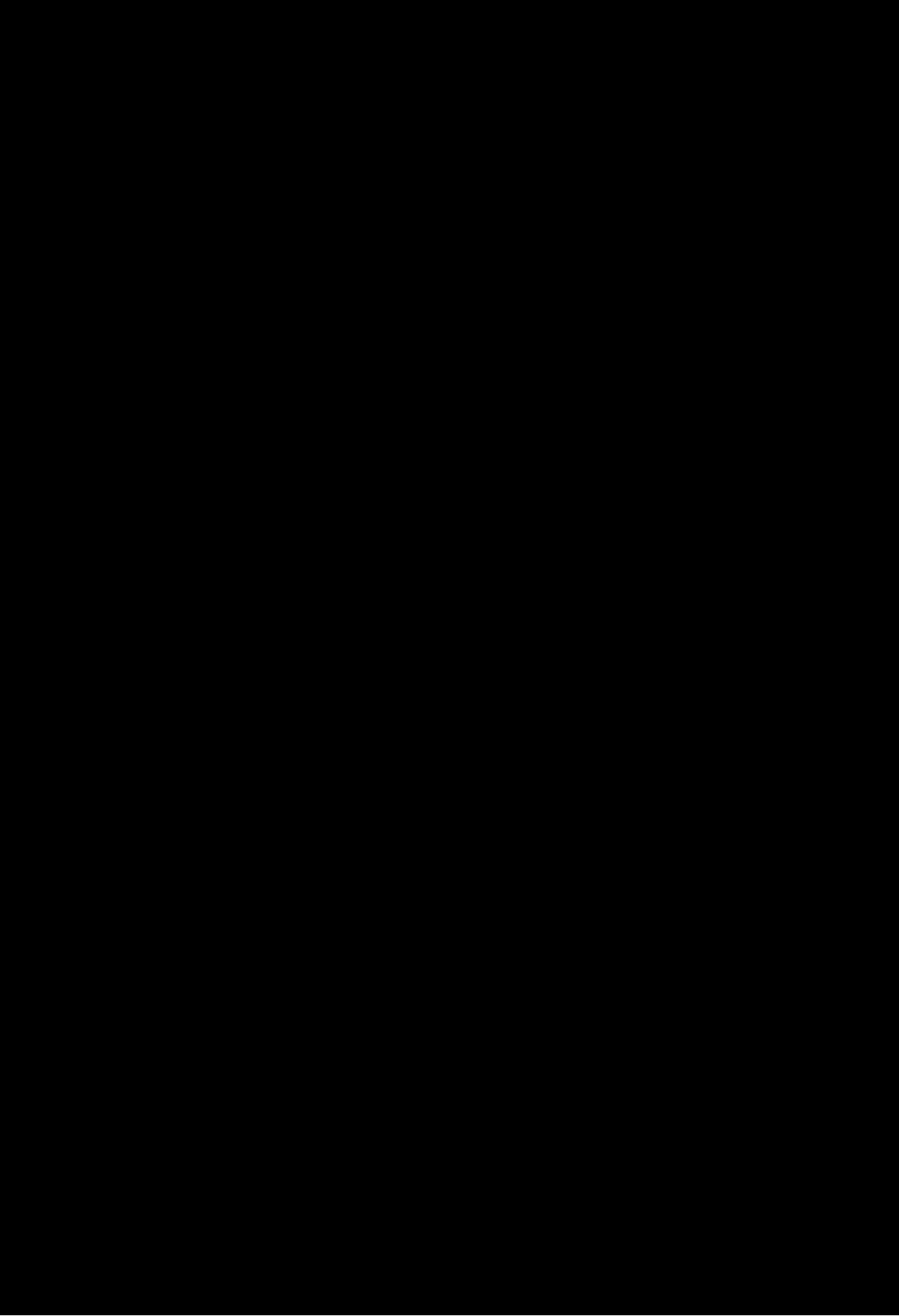

\_\_\_\_\_  
\_\_\_\_\_  
\_\_\_\_\_  
\_\_\_\_\_  
\_\_\_\_\_  
\_\_\_\_\_

\_\_\_\_\_

0

\_\_\_\_\_  
\_\_\_\_\_

60

## 16.1.6.1

```

                                NAT      Net200
200.168.12.2~200.168.12.100          1          NAT

!
interface GigabitEthernet 0/0
ip address 192.168.12.1 255.255.255.0
ip nat inside
!
interface GigabitEthernet 1/0
ip address 200.168.12.1 255.255.255.0
ip nat outside
!
ip nat pool net200 200.168.12.2 200.168.12.100 netmask 255.255.255.0
ipnat inside source list 1 pool net200
!
access-list 1 permit 192.168.12.0 0.0.0.255
```

## 16.1.6.2

```

                                NAPT      8.1          NAT
                                NAT      Net200
NAPT      IP
200.168.12.200      NAT
                                NAT
!
interface GigabitEthernet 0/0
ip address 192.168.12.1 255.255.255.0
ip nat inside
!
interface GigabitEthernet 1/0
ip address 200.168.12.200 255.255.255.0
ip nat outside
!
ip nat pool net200 200.168.12.200 200.168.12.200 netmask 255.255.255.0
ip nat inside source list 1 pool net200
access-list 1 permit 192.168.12.0 0.0.0.255

                                NAT

Ruijie# show ip nat translations
```

```

Pro Inside global      Inside local      Outside local      Outside
global
tcp 200.168.12.200:2063 192.168.12.65:2063 168.168.12.1:23
168.168.12.1:23

```

### 16.1.6.3

### NAPT

NAPT

NAPT

NAT

```

WEB      192.168.12.3      IP200.198.12.1  80

```

```

!
interface GigabitEthernet 0/0
ip address 192.168.12.1 255.255.255.0
ip nat inside
!
interface GigabitEthernet 1/0
ip address 200.198.12.1 255.255.255.0
ip nat outside
!
ip nat inside source static tcp 192.168.12.3 80 200.198.12.1 80

```

### 16.1.6.4 TCP

1  
TCP

IP ACL

Realhosts  
TCP  
NAT ACL

```

!
interface GigabitEthernet 0/0
ip address 10.10.10.1 255.255.255.0
ip nat inside
!
interface GigabitEthernet 1/0
ip address 200.198.12.1 255.255.255.0
ip nat outside
!

```

```

ip nat pool realhosts 10.10.10.2 10.10.10.3 netmask 255.255.255.0 type
rotary
ip nat inside destination list 100 pool realhosts
!
access-list 100 permit ip any host 10.10.10.100
!

```

NAT

```

Ruijie# sh ip nat translations
Pro Inside global   Inside local   Outside local   Outside global
tcp 10.10.10.100:23 10.10.10.2:23 100.100.100.100:1178
100.100.100.100:1178
tcp 10.10.10.100:23 10.10.10.3:23 200.200.200.200:1024
200.200.200.200:1024

```

16.1.6.5 NAT outside

- WAN NAT Outside WAN
- WAN
- NAT **ip default-route balance by-source**
- Outside NBR1000 WAN
- NBR1000
- Interface GigabitEthernet 1/0 100M IP
  - Interface GigabitEthernet 1/1 1M ADSL PPPoE

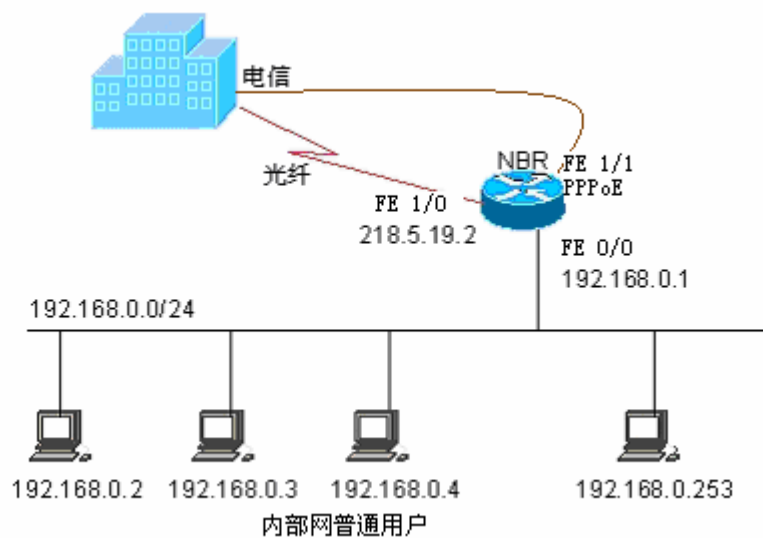



```
dialer idle-timeout 1200
dialer-group 1

#    1M    Kbits

bandwidth 1000
!

#    NAT            NAT    Outside    Outside    GigabitEthernet 1/0
    218.5.19.2      Outside  Dialer 1   PPPoE      Dialer

ip nat pool nbr_setup_build_pool prefix-length 24
address 218.5.19.2 218.5.19.2 match interface GigabitEthernet 1/0
address interface dialer 1 match interface dialer 1

#    NAT

ip nat inside source list 99 pool nbr_setup_build_pool

#                WAN

ip route 0.0.0.0 0.0.0.0 GigabitEthernet 1/0 202.101.98.1
ip route 0.0.0.0 0.0.0.0 dialer 1
!
```

### 16.1.6.6

```
                WEB            E-MAIL            )                2                (FTP
                NAT            NAT            Internet
```

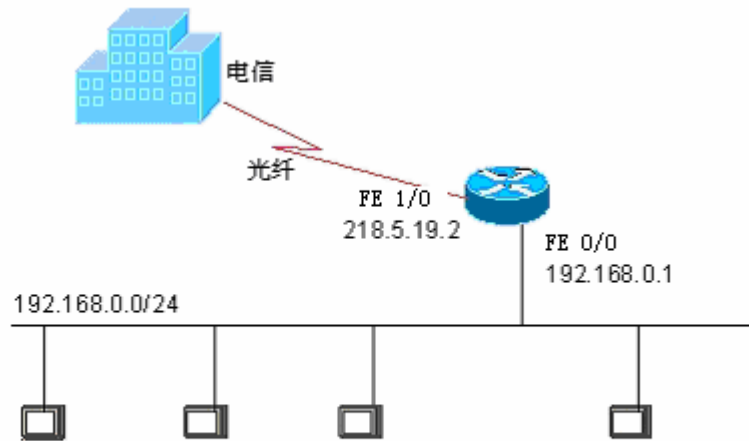

2

NAT

#

Ruijie> **enable**

#

Ruijie# **config terminal**

Enter configuration commands, one per line. End with CNTL/Z.

# **WAN0**Ruijie(config)#**interface GigabitEthernet 1/0**# **WAN**Ruijie(config-if)# **ip address 218.5.19.2 255.255.255.0**# **WAN Internet**Ruijie(config-if)# **ip nat outside**# **WAN**Ruijie(config-if)# **no shut**

#

Ruijie(config-if)# **end**

Ruijie#

# **WAN UP ( )**.

%LINK CHANGED: Interface GigabitEthernet 1/0, changed state to up

```
%LINE PROTOCOL CHANGE: Interface GigabitEthernet 1/0, changed state to
UPRuijie# config terminal
Enter configuration commands, one per line. End with CNTL/Z.

# LAN

Ruijie(config)# interface GigabitEthernet 0/0

# LAN

Ruijie(config-if)# ip address 192.168.0.1 255.255.255.0

# LAN Intranet

Ruijie(config-if)# ip nat inside

# LAN

Ruijie(config-if)# no shut
Ruijie(config-if)# end
Ruijie#
%LINK CHANGED: Interface GigabitEthernet 0/0, changed state to up
%LINE PROTOCOL CHANGE: Interface GigabitEthernet 0/0, changed state to
UP
Ruijie# config terminal
Enter configuration commands, one per line. End with CNTL/Z.

# Internet

Ruijie(config)# ip route 0.0.0.0 0.0.0.0 GigabitEthernet 1/0 218.5.19.1

# NAT

Ruijie(config)# access-list 1 permit any

#

Ruijie(config)#ip nat inside source list 1 interface GigabitEthernet 1/0

# FTP

Ruijie(config)# ip nat inside source static tcp 192.168.0.2 20 218.5.19.2
20
Ruijie(config)# ip nat inside source static tcp 192.168.0.2 21 218.5.19.2
21

# WEB

Ruijie(config)# ip nat inside source static tcp 192.168.0.3 80 218.5.19.2
80

# EMAIL

Ruijie(config)# ip nat inside source static tcp 192.168.0.4 25 218.5.19.2
25
```

```
Ruijie(config)# ip nat inside source static tcp 192.168.0.4 110
218.5.19.2 110
Ruijie(config)# end
Ruijie#
Ruijie# config terminal
Enter configuration commands, one per line. End with CNTL/Z.

#           Telnet

Ruijie(config)# line vty 0 4
Ruijie(config-line)# password remoteuser
Ruijie(config-line)# end
Ruijie#
Ruijie# config terminal
Enter configuration commands, one per line. End with CNTL/Z.
Ruijie(config)# enable secret private

#

Ruijie(config)# host NBR
RUIJIE(config)# end
RUIJIE#

#

RUIJIE# write
Building configuration...
[OK]
RUIJIE#

#

RUIJIE# show running-config
Building configuration...
Current configuration:
!
!
hostname NBR
!
!
access-list 1 permit any
!
!
interface GigabitEthernet 0/0
ip address 192.168.0.1 255.255.255.0
ip nat inside
```

```
!  
interface GigabitEthernet 1/0  
ip address 218.5.19.2 255.255.255.0  
ip nat outside  
!  
ip nat inside source list 1 interface GigabitEthernet 1/0  
ip nat inside source static tcp 192.168.0.4 110 218.5.19.2 110  
ip nat inside source static tcp 192.168.0.4 25 218.5.19.2 25  
ip nat inside source static tcp 192.168.0.3 80 218.5.19.2 80  
ip nat inside source static tcp 192.168.0.2 21 218.5.19.2 21  
ip nat inside source static tcp 192.168.0.2 20 218.5.19.2 20  
!  
ip route 0.0.0.0 0.0.0.0 GigabitEthernet 1/0 218.5.19.1  
!  
line con 0  
line vty 0 4  
password remoteuser  
login  
!  
end  
RUIJIE#
```

### 16.1.6.7 vrf nat

```
                vrf  nat                vrf                nat                vrf  
  
access-list 1 permit 192.168.12.0 0.0.0.255  
  
ip vrf 1  
  
ip vrf 2  
  
interface GigabitEthernet 0/0  
ip vrf forward 1  
ip address 192.168.12.1 255.255.255.0  
ip nat inside  
!  
interface GigabitEthernet 0/1  
ip vrf forward 1  
ip address 100.168.12.200 255.255.255.0  
ip nat outside
```

```
!  
interface GigabitEthernet 1/0  
ip vrf forward 2  
ip address 192.168.12.1 255.255.255.0  
ip nat inside  
!  
interface GigabitEthernet 1/1  
ip vrf forward 2  
ip address 200.168.12.200 255.255.255.0  
ip nat outside  
!  
ip nat pool net100 100.168.12.200 100.168.12.200 netmask 255.255.255.0  
ip nat pool net200 200.168.12.200 200.168.12.200 netmask 255.255.255.0  
  
ip nat inside source list 1 pool net100 vrf 1  
ip nat inside source list 1 pool net200 vrf 2
```

### NAT

```
Ruijie# show ip nat translations vrf 1  
Pro Inside global      Inside local      Outside local      Outside  
global  
tcp 100.168.12.200:2063 192.168.12.65:2063 168.168.12.1:23  
168.168.12.1:23  
Ruijie# show ip nat translations vrf 2  
Pro Inside global      Inside local      Outside local      Outside  
global  
tcp 200.168.12.200:2063 192.168.12.65:2063 168.168.12.1:23  
168.168.12.1:23
```

16.1.6.8

NAT

```
ip nat outside
!
ip nat inside source static 192.168.12.0 200.198.12.0 netmask
255.255.255.0
```

16.1.6.9 NAT DNS

NAT dns alg dns ISP DNS

1. ftp
2. dns
3. DNS
4. DNS
5. DNS

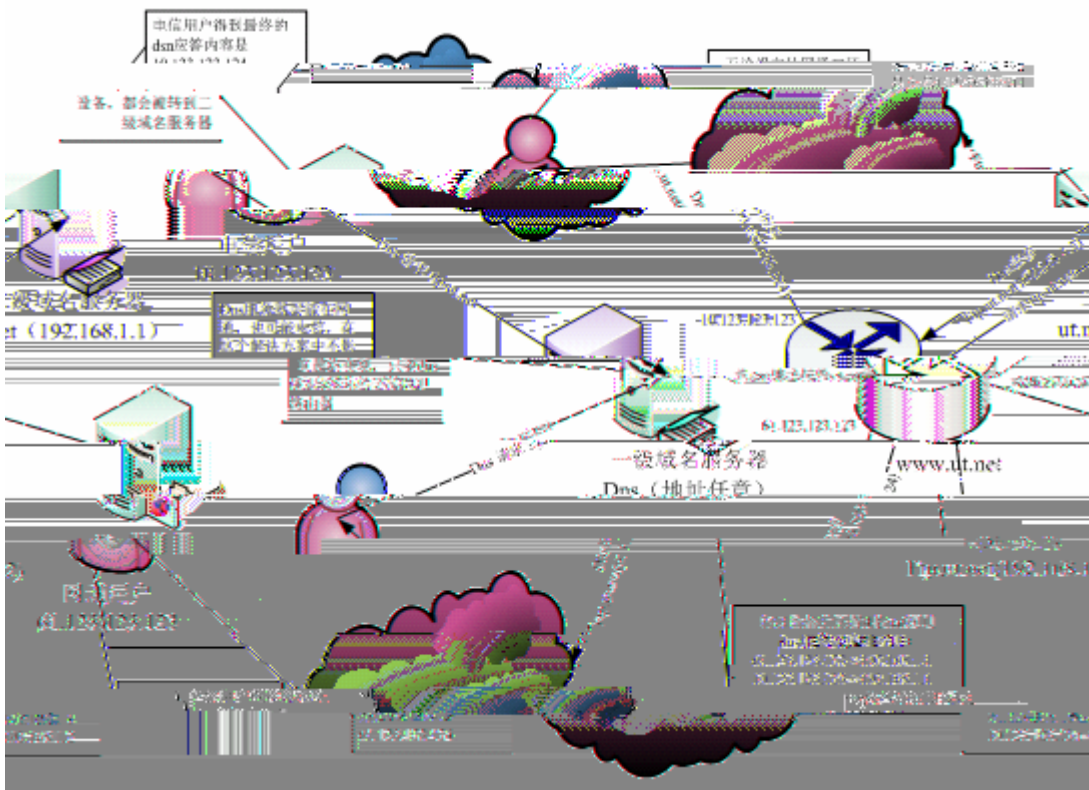

```
interface GigabitEthernet 0/0
  ip address 10.123.123.123 255.255.255.0
  ip nat outside
  duplex auto
  speed auto
  description
interface GigabitEthernet 0/1
  ip address 61.123.123.123 255.255.255.0
  ip nat outside
  duplex auto
  speed auto
  description
interface GigabitEthernet 0/2
  ip address 192.168.1.254 255.255.255.0
  ip nat inside
  duplex auto
  speed auto
  description
/*dns      */
ip nat inside source static 192.168.1.1 61.123.123.123
/*          */
ip nat inside source static 192.168.1.2 10.123.123.124 match gigabitEthernet 0/0
/*          */
ip nat inside source static 192.168.1.2 61.123.123.124 match gigabitEthernet 0/1
```

---

# 17

## 17.1

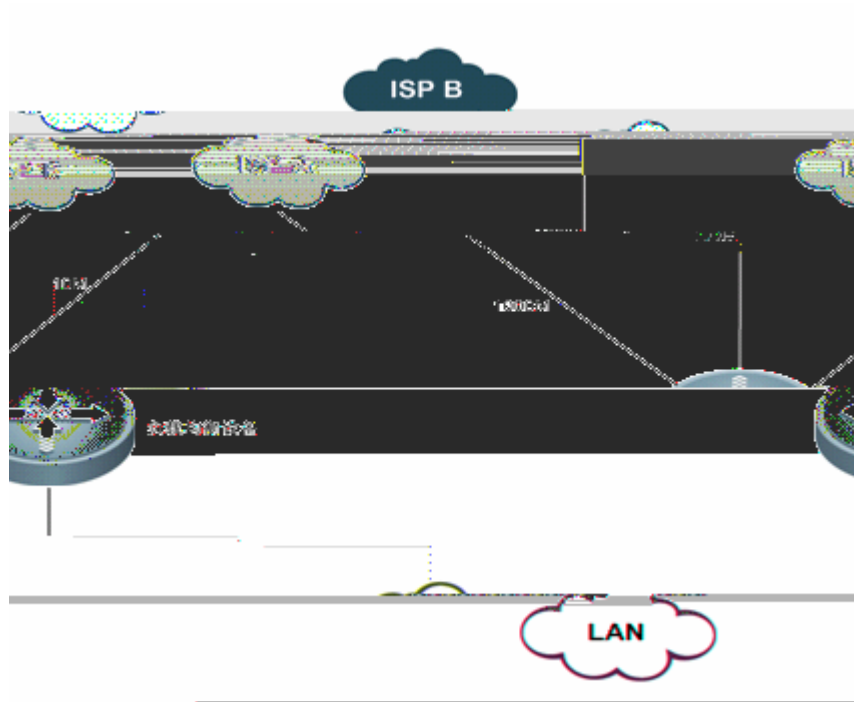

1.

### 17.1.1

2

/

### 17.1.2

#### 17.1.2.1





---

#

Ruijie# **configure terminal**

Enter configuration commands, one per line. End with CNTL/Z.

Ruijie(config)# **interface fastEthernet 0/1**

Ruijie(config-if)# **no bandwidth**

### 17.3.3

1 100.

| <b>Step 1</b> | Ruijie# <b>configure terminal</b>             |                |
|---------------|---|----------------|
| <b>Step 2</b> | Ruijie(config)# <b>mllb threshold percent</b> | <i>percent</i> |
|               |   | 1-100          |
|               | Ruijie(config)# <b>no mllb threshold</b>      | 100            |

# 95

Ruijie# **configure terminal**

Enter configuration commands, one per line. End with CNTL/Z.

Ruijie(config)# **mllb threshold 95**

#

Ruijie# **configure terminal**

Enter configuration commands, one per line. End with CNTL/Z.

Ruijie(config)# **no mllb threshold**

### 17.3.4

4

---

|               |  |       |
|---------------|--|-------|
| <b>Step 1</b> | Ruijie# <b>configure terminal</b>  |       |
| <b>Step 2</b> | Ruijie(config)# <b>mlb policy { bandwidth   latency   load   intelligent }</b> | / / / |
|               | Ruijie(config)# <b>no mlb policy</b>   |       |

# bandwidth

Ruijie# **configure terminal**

Enter configuration commands, one per line. End with CNTL/Z.

Ruijie(config)# **mlb policy bandwidth**

### 17.3.5

intelligent

---

IP

| <b>Step 1</b> | Ruijie# <b>configure terminal</b>                   |    |
|---------------|---|----|
| <b>Step 2</b> | Ruijie(config)# <b>mlb load-sharing original</b>    | IP |
|               | Ruijie(config)# <b>no mlb load-sharing original</b> |    |



---

```
Ruijie# exit
#      2

Ruijie(config)# interface gigabitEthernet 0/3

Ruijie(config-if)# bandwidth 10000

Ruijie# exit

3

#           bandwidth

Ruijie(config)#mllb policy bandwidth

4

#           95

Ruijie(config)# mllb threshold 95
```



---

# 18

## 18.1

### 18.1.1

vlan IP IP

### 18.1.2

IP vlan vlan tag IP

#### 18.1.2.1 vlan

---

### 18.1.2.3

ip

## 18.2

|  |  |
|--|--|
|  |  |
|  |  |

## 18.3

- ---

### 18.3.1

|  |  |
|--|--|
|  |  |
| Ruijie# <b>configure terminal</b>              |  |
| Ruijie(config)# <b>layer23 classify enable</b> |  |
| Ruijie(config)# <b>end</b>                     |  |
| Ruijie# <b>show running</b>                    |  |

**no layer23 classify enable**

#

```
Ruijie#configure terminal
```

```
Enter configuration commands, one per line. End with CNTL/Z.
```

```
Ruijie(config)#layer23 classify enable
```

```
Ruijie(config)#end
```

## 18.4      **vlan**

- 
- vlan

## 18.4.1 vlan

vlan

vlan



---

| vlan-group | police_flow | police_url | flow  | vlan id |
|------------|-------------|------------|-------|---------|
| -----      | -----       | -----      | ----- | -----   |
| any        | 9           | 0          | 0     |         |

---

ip

mac

---

/group1

user3

192.168.199.1

00-d0-f8-21-da-29

# "userfile"

Ruijie# **subscriber import txt userfile**

### **18.6.3**

---

## 18.8

- \_\_\_\_\_

### 18.8.1

| Step 1 | Ruijie# <b>configure terminal</b>  |  |
|--------|--|--|
| Step 2 | Ruijie(config)# <b>network-group name</b> <i>name</i><br>{ <b>ip-host</b> <i>ip-addr</i>   <b>ip-subnet</b> <i>subnet mask</i>  <br><b>ip-range</b> <i>start end</i> } |  |
| Step 3 | Ruijie(config)# <b>end</b>   |  |
| Step 4 | Ruijie# <b>show network-group</b>  |  |

**no network-group** *name*

ip                      ip                      ip                      ip  
                         " /"                      " /"                      ip

```
# ip                      network1              192.168.196.0
```

```
Ruijie#configure terminal
```

```
Ruijie(config)# network-group name network1 ip-subnet 192.168.196.0  
255.255.255.0
```

```
Ruijie(config)#end
```

## 18.9

| Ruijie# <b>show network-group</b> [ <i>name</i> ] | show network-group |
|---|--------------------|

---

#

Ruijie#show network-group

| network-group | police_flow | police_url | flow | ip            |
|---------------|-------------|------------|------|---------------|
| /             | 9           | 0          | 351  |               |
| network1      | 0           | 2          | 0    | 192.168.197.3 |
| network2      | 0           | 0          | 0    | 192.168.197.1 |
| network3      | 0           | 0          | 0    | 192.168.197.2 |

---

# 19

## 19.1

### 19.1.1

### 19.1.2

#### 19.1.2.1

```
17          17          "          " "IP
" " P2P          " "
" "          " "
" " RFC" " HTTP          "
"

show identify-application group-state
```

---

1



Q1 "

/ / /

QQ

QQ

QQ

QQ

.48B2-228BT /C20 1 Tf 10.02 0.5 0 0 10.0

---

## 19.3.1

| <b>Step 1</b> | Ruijie# <b>configure terminal</b>                  |  |
|---------------|--|--|
| <b>Step 2</b> | Ruijie(config)# <b>identify-application enable</b> |  |
| <b>Step 4</b> | Ruijie(config)# <b>end</b>                         |  |
| <b>Step 5</b> | Ruijie# <b>show running</b>                        |  |

**no identity-application enable**

```
#          3>07FJ/TT1 1 Tfs-5(d)]TJ/TT0 1 Tf0 126 0 Td<4589]TJ/C2_03(i6[(
```

### 19.3.3

|               |   |  |
|---------------|---|--|
| <b>Step 1</b> | Ruijie# <b>configure terminal</b>   |  |
| <b>Step 2</b> | Ruijie(config)# <b>identify-application custom name</b> <i>app-name</i> <b>class</b> <i>class-name</i> <b>{tcp udp}</b> <b>sport</b> <i>sport-low sport-high</i> <b>dport</b> <i>dport-low dport-high</i> | <pre> app-name class-name class-name    app-name sport-low     0-65535    any sport-high    0-65535    any dport-low     0-65535    any dport-high    0-65535    any sport-low     sport-high dport-low     dport-high                 sport    sport                 dport   dport </pre> |
| <b>Step 4</b> | Ruijie(config)# <b>end</b>  |  |
| <b>Step 5</b> | Ruijie# <b>show userdef-rule identify-application</b>   |  |

```

no identify-application custom name
app-name class class-name {tcp|udp} sport sport-low sport-high dport dport-low
dport-high

```

|   |   |          |           |
|---|---|----------|-----------|
|  | 1 | app-name | app-class |
|   | 2 | app-name | app-class |

#

```
Ruijie# configure terminal
```

```
Enter configuration commands, one per line. End with CNTL/Z.
```

```
Ruijie(config)# identify-application custom name class
```

```
tcp sport 1 10 dport 1 100
```

```
Ruijie#end
```

```
Ruijie#*Jan 11 17:25:29: %SYS-5-CONFIG_I: Configured from console by
console
```

---

Ruijie#**show identify-application userdef-rule**

| TYPE | NAME | CLASS | SPL | SPH | DPL | DPH |
|------|------|-------|-----|-----|-----|-----|
| TCP  |      |       | 1   | 10  | 1   | 100 |

#

Ruijie# **configure terminal**

Enter configuration commands, one per line. End with CNTL/Z.

Ruijie(config)# **identify-application custom name myqq class im udp sport 1 10 dport any any**

Ruijie#**end**

Ruijie#\*Jan 11 17:25:29: %SYS-5-CONFIG\_I: Configured from console by console

Ruijie#**show identify-application userdef-rule**

| TYPE | NAME | CLASS | SPL | SPH | DPL | DPH |
|------|------|-------|-----|-----|-----|-----|
| TCP  |      |       | 1   | 10  | 1   | 100 |
| UDP  | myqq |       |     |     |     |     |

---

|                    |                 |
|--------------------|-----------------|
| tunnel             | Tunnel software |
| video              | Video software  |
| db                 |                 |
| email              |                 |
| file-trans         |                 |
| game               |                 |
| http-app           | HTTP            |
| im                 |                 |
| iphone             | IP              |
| network-management |                 |
| other              |                 |
| p2p                | P2P             |
| remote-access      |                 |
| rfc                | RFC             |
| route              |                 |
| security           |                 |
| stock              |                 |
| tunnel             |                 |
| video              |                 |

#### 19.3.4

}

---

## no identity-application key *app-name*

```
# FTP
Ruijie# configure terminal
Enter configuration commands, one per line. End with CNTL/Z.
Ruijie(config)# identify-application key FTP
Ruijie(config)#
```

### 19.3.5

| Step 1 | Ruijie# <b>configure terminal</b>  |                 |
|--------|--|-----------------|
| Step 2 | Ruijie(config)# <b>identify-application</b><br><b>inhibitive</b> <i>app-name</i> | <i>app-name</i> |
| Step 4 | Ruijie(config)# <b>end</b>   |                 |
| Step 5 | Ruijie# <b>show identity-application inhibitive</b>                              |                 |

## no identity-application inhibitive

*app-name*

```
# QQ
Ruijie# configure terminal
Enter configuration commands, one per line. End with CNTL/Z.
Ruijie(config)# identify-application key QQ
Ruijie(config)#
```

### 19.3.6

| <b>show identify-application version</b>      |  |
|---|--|
| <b>show identity-application userdef-rule</b> |  |
| <b>show identity-application</b>              |  |

---

|  |  |
|--|--|
| <b>show identity-application key</b>         |  |
| <b>show identity-application inhibitive</b>  |  |
| <b>show identity-application class</b>       |  |
| <b>show identity-application group-state</b> |  |

---

#

Ruijie# show **identify-application custom version**

Version 1.0

Date 2010-1-8

#

Ruijie#**show identify-application userdef-rule**

| TYPE | NAME | CLASS | SPL | SPH | DPL | DPH |
|------|------|-------|-----|-----|-----|-----|
| TCP  |      |       | 1   | 10  | 1   | 100 |
| UDP  | myqq |       | 1   | 10  | any | any |

#

Ruijie#**show identity-application**

any 255-4095-63-48

1-0-0-0

1-1-0-0

MSN 1-6-0-0

MSN-CHAT 1-6-1-0

MSN-AUDIO 1-6-2-0

MSN-FILE 1-6-3-0

MSN- 1-6-4-0

MSN- 1-6-5-0

QQ 1-7-0-0

QQ-CHAT 1-7-1-0

QQ- 1-7-2-0

QQ- 1-7-3-0

QQ- 1-7-4-0

QQ- 1-7-5-0

QQ- 1-7-14-0

WEBIM 1-9-0-0

MSN-WEBIM 1-9-1-0

YAHOO-WEBIM 1-9-2-0

---

#

Ruijie#**show identity-application key**

IP

    QQ

MSN

FTP

#

Ruijie#**show identity-application inhibitive**

#

Ruijie#**show identity-application class**

    1-0-0-0

IP    2-0-0-0

    3-0-0-0

    4-0-0-0

P2P

14 4-0-1

---

app group state: on //on

## 19.4

---

# 20

## 20.1

### 20.1.1

(Flow Control)

P2P

### 20.1.2

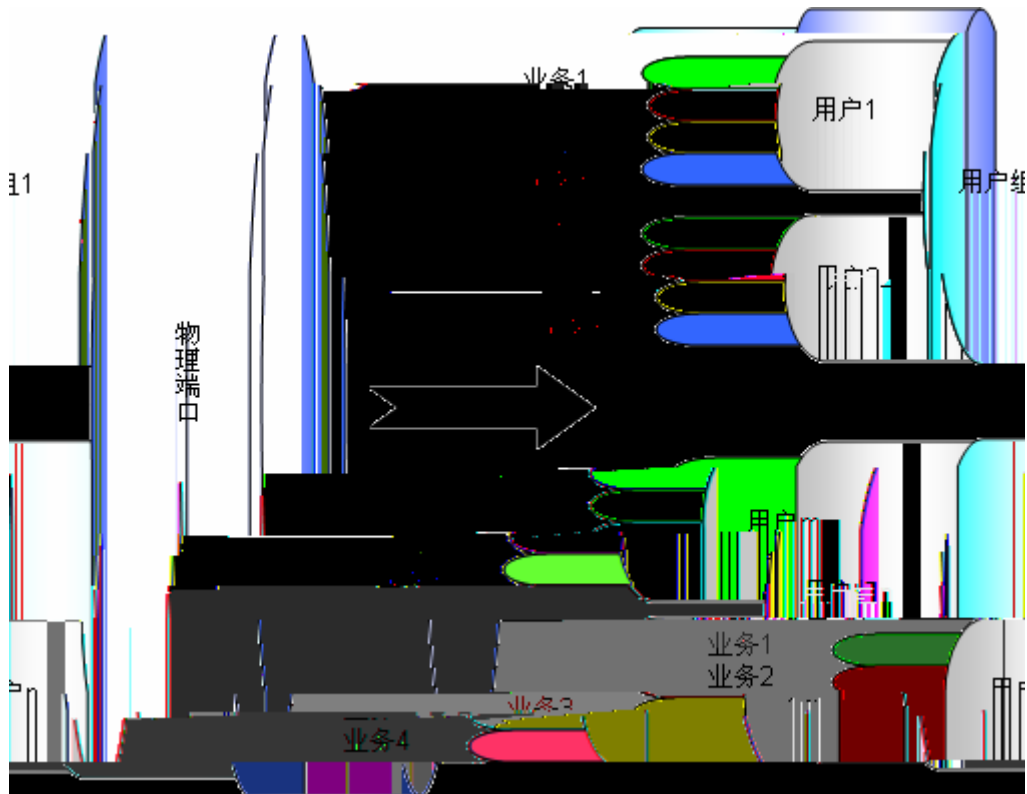

---

20.1.2.1

20.1.2.1.1



- 
- 1.
  - 2.
- 

20.1.2.1.2

**cir**

**cir**

**pir**

**cir**

**pir pir**

**pir**

**cir**

---

SFQ

Per-net

Per-net

SFQ

128



- \_\_\_\_\_
- \_\_\_\_\_

### 20.3.1

| Step 1 | Ruijie# <b>configure terminal</b>               |  |
|--------|---|--|
| Step 2 | Ruijie(config)# <b>flow-control</b> <i>Name</i> |  |
| Step 3 | Ruijie# <b>show running</b>                     |  |

**no flow-control** *Name*

|   |    |
|---|----|
|  | 10 |
|---|----|

#

```
Ruijie# configure terminal
Enter configuration commands, one per line. End with CNTL/Z.
Ruijie(config)# flow-control DianXin
Ruijie(config-flow-control))# end
```

### 20.3.2

| Step 1 | Ruijie# <b>configure terminal</b>  |                     |
|--------|--|---------------------|
| Step 2 | Ruijie(config)# <b>flow-control</b> <i>Name</i>                          |                     |
| Step 3 | Ruijie(config-flow-control)# <b>exit</b>                                 | <b>flow-control</b> |
| Step 4 | Ruijie(config)# <b>interface</b> <i>Gi 0/1</i>                           |                     |
| Step 5 | Ruijie(config-if-GigabitEthernet 0/1)#<br><b>flow-policy</b> <i>Name</i> | Gi 0/1              |
| Step 6 | Ruijie(config-if-GigabitEthernet 0/1)# <b>end</b>                        |                     |
| Step 7 | Ruijie# <b>show running</b>  |                     |

---

```

Ruijie# configure terminal
Enter configuration commands, one per line. End with CNTL/Z.
Ruijie(config)# flow-control DianXin
Ruijie(config-flow-control)# channel-tree inbound
Ruijie(config-channel-tree)#exit
Ruijie(config-flow-control)# channel-tree outbound
Ruijie(config-channel-tree)#end

```

### 20.3.4

| <b>Step 1</b> | Ruijie# <b>configure terminal</b>   |  |
|---------------|---|--|
| <b>Step 2</b> | Ruijie(config)# <b>flow-control</b> <i>Name</i>   |  |
| <b>Step 3</b> | Ruijie(config-flow-control)# <b>channel-tree inbound</b>  |  |
| <b>Step 4</b> | Ruijie(config-channel-tree)# <b>channel-group</b><br><i>name</i> <b>parent</b> {NULL   <i>parent_name</i> } <b>cir</b><br><i>cir_num</i> <b>pir</b> <i>pir_num</i> [ <b>pri</b> <i>pri_num</i> ]<br>[ <b>schedule-type</b> {fifo   sfq   <b>per-net per-mask</b><br><i>mask</i> <b>per-cir</b> <i>pcir_num</i> <b>per-pir</b> <i>ppir_num</i> <b>limit</b><br><i>limit_num</i> }] |  |
| <b>Step 6</b> | Ruijie(config-channel-tree)# <b>end</b>   |  |
| <b>Step 7</b> | Ruijie# <b>show running</b>   |  |

|   | channel-tree                | no channel-group <i>Name</i>     |
|---|-----------------------------|----------------------------------|
|   |                             | <b>cir</b> <b>pir</b>            |
|   | <b>cir</b>                  | <b>cir</b> <b>cir</b>            |
|   | <b>cir</b> <b>pir</b>       | <b>pir</b> <b>cir</b> <b>pir</b> |
|  | <b>sfq</b> <b>per-net</b>   |                                  |
|   | <b>per-net</b> <b>limit</b> | <b>per-net</b>                   |
|   |                             | <b>limit</b>                     |

---

```

# root
Ruijie# configure terminal
Enter configuration commands, one per line. End with CNTL/Z.
Ruijie(config)# flow-control DianXin
Ruijie(config-flow-control)# channel-tree inbound
Ruijie(config-channel-tree)# channel-group root parent null cir 100000
pir 100000 pri 4 schedule-type fifo
Ruijie(config-channel-tree)# end

```

### 20.3.5

| <b>Step 1</b> | Ruijie# <b>configure terminal</b>                                     |                           |
|---------------|---|---------------------------|
| <b>Step 2</b> | Ruijie(config)# <b>flow-control</b> <i>Name</i>                       |                           |
| <b>Step 3</b> | Ruijie(config-flow-control)# <b>channel-tree inbound</b>              |                           |
| <b>Step 4</b> | Ruijie(config-channel-tree)# <b>channel-default</b><br><i>channel</i> |                           |
| <b>Step 6</b> | Ruijie(config-channel-tree)# <b>end</b>                               |                           |
| <b>Step 7</b> | Ruijie# <b>show running</b>   |                           |
|               | <b>channel-tree</b>   | <b>no channel-default</b> |

|               |  |  |
|---------------|--|--|
| <b>Step 1</b> | Ruijie# <b>configure terminal</b>  |  |
| <b>Step 2</b> | Ruijie(config)# <b>flow-control</b> <i>Name</i>  |  |
| <b>Step 3</b> | Ruijie(config-flow-control)# <b>flow-rule</b> <i>num</i><br><b>vlan-group</b> <i>vlan-group-name</i> <b>subscriber</b><br><i>subscriber-name</i> <b>network-group</b><br><i>network-group-name</i> <b>app-group</b><br><i>app-group-name</i> <b>time-range</b> <i>time-rang-name</i>           |  |
| <b>Step 4</b> | Ruijie(config-flow-control)# <b>flow-rule</b> <i>num</i><br><b>session-limit</b> <i>session-num</i> <b>action</b> { <b>drop /</b><br><b>log-drop / pass</b> [ <b>in-channel</b><br><i>in-channel-name</i> ] [ <b>out-channel</b><br><i>out-channel-name</i> ]} [ <b>commet</b> <i>string</i> ] |  |
| <b>Step 6</b> | Ruijie(config-flow-control)# <b>end</b>  |  |
| <b>Step 7</b> | Ruijie# <b>show running</b>  |  |

flowl-control

no flow-rule *num*



```
#                               3M                 300

Ruijie# configure terminal
Enter configuration commands, one per line. End with CNTL/Z.
Ruijie(config)# flow-control DianXin
Ruijie(config-flow-control)# flow-rule 1 vlan-group any subscriber
network-group any time-range any
Ruijie(config-flow-control)# flow-rule 1 session-limit 300 action pass
out-channel                 3M
Ruijie(config-flow-control)# end
```

## 20.3.7

| <b>Step 1</b> | Ruijie# <b>configure terminal</b>  |      |     |
|---------------|--|------|-----|
| <b>Step 2</b> | Ruijie(config)# <b>flow-control</b> <i>Name</i>  |      |     |
| <b>Step 3</b> | Ruijie(config-flow-control)# <b>change-priority</b><br><b>rule1</b> <i>rule1-pri-num</i> <b>rule2</b> <i>rule2-pri-num</i> | Name | 1 2 |
| <b>Step 4</b> | Ruijie(config-flow-control)# <b>end</b>  |      |     |
| <b>Step 5</b> | Ruijie# <b>show running</b>  |      |     |

|  | Pri_num | show flow-control-policy rule |  |
|---|---------|-------------------------------|--|

```
#
1 2
1 2
Ruijie# configure terminal
```

---

```
root                1000000 1000000 4  fifo
```

```
#
```

```
Ruijie#show flow-control test inbound
```

```
group-name          cir      pir      pri  schedule
```

```
-----  
root                1000000 1000000 4  fifo  
part1               700000  1000000 4  fifo  
part2               200000  1000000 4  fifo  
part3               100000  1000000 4  fifo
```

## 20.5

---

```
Ruijie(config)# show flow-control-policy group
```

---

```
#
```

```
Ruijie#show flow-control-policy group
```

```
group_name          group_id  apply_ifx  policy_entries  
group1              0         6          14  
group2              1         0          4
```

## 20.6

---

```
Ruijie(config)# show flow-control-policy rule  
[group name]
```

---

```
#
```

```
Ruijie#show flow-control-policy rule
```

```
Pri_num  grp_id  rule_num  ifx   vlan_id  subs_id  net_wk_id  app_id  
ichl_id  ochl_id  ses_num  ses_lim  effec  
1         0       1         0     0        814695740  0          0  
NA        2       0         2000  0
```

---

```

2      0      2      0      18661884      18577704      18577496      0
1      NA     0      2000      0
3      1      3      6      18661884      18577704      18577496
4294967290
1      1      0      2000      1

```

#

Ruijie#**show flow-control-policy rule group** DianXin

```

Pri_num grp_id rule_num ifx  vlan_id  subs_id  net_wk_id  app_id
ichl_id ochl_id ses_num ses_lim effec
1      0      1      0      0      814695740  0      0
NA     2      0      2000      0
2      0      2      0      18661884  18577704  18577496  0
1      NA     0      2000      0

```

## 20.7

---

```
#
Ruijie(config)# flow-control Corp
#
Ruijie(config-flow-control)# channel-tree inbound
Ruijie(config-channel-tree)# channel-group root parent null cir 10000
pir 10000 pri 4 schedule-type fifo
Ruijie(config-channel-tree)# channel-group department1 parent root cir
5000 pir 10000 pri 4 schedule-type fifo
Ruijie(config-channel-tree)# channel-group department2 parent root cir
3000 pir 10000 pri 4 schedule-type fifo
Ruijie(config-channel-tree)# channel-group department3 parent root cir
2000 pir 10000 pri 4 schedule-type fifo
Ruijie(config-channel-tree)# exit
#
Ruijie(config-flow-control)# channel-tree outbound
Ruijie(config-channel-tree)# channel-group root parent null cir 10000
pir 10000 pri 4 schedule-type fifo
Ruijie(config-channel-tree)# channel-group department1 parent root cir
5000 pir 10000 pri 4 schedule-type fifo
Ruijie(config-channel-tree)# channel-group department2 parent root cir
3000 pir 10000 pri 4 schedule-type fifo
Ruijie(config-channel-tree)# channel-group department3 parent root cir
2000 pir 10000 pri 4 schedule-type fifo
Ruijie(config-channel-tree)# exit
Ruijie(config-flow-control)# exit
```

2

```
Ruijie# configure terminal
#
Ruijie(config)# identify-application enable
#
Ruijie(config)# subscriber static name department1 parent / ip-subnet
192.168.1.0 255.255.255.0
Ruijie(config)# subscriber static name department2 parent / ip-subnet
192.168.2.0 255.255.255.0
Ruijie(config)# subscriber static name department3 parent / ip-subnet
192.168.3.0 255.255.255.0
#
Ruijie(config)# time-range any any
Ruijie(config-time-range)# periodic Daily 0:00 to 23:59
```

---

3

```
Ruijie# configure terminal
Ruijie(config)# flow-control Corp
#      1 2 3          department1 department2 department3
Ruijie(config-flow-control)# flow-rule 1 vlan-group any subscriber
department1 network-group any app-group any time-rang any
Ruijie(config-flow-control)# flow-rule 1 session-limit 0 action pass
in-channel department1 out-channel department1
Ruijie(config-flow-control)# flow-rule 2 vlan-group any subscriber
department2 network-group any app-group any time-rang any
Ruijie(config-flow-control)# flow-rule 2 session-limit 0 action pass
in-channel department2 out-channel department2
Ruijie(config-flow-control)# flow-rule 3 vlan-group any subscriber
department3 network-group any app-group any time-rang any
Ruijie(config-flow-control)# flow-rule 3 session-limit 0 action pass
in-channel department3 out-channel department3
```

4

```
Ruijie# configure terminal
Ruijie(config)# interface GigabitEthernet 0/1
Ruijie(config-if-GigabitEthernet 0/1)# flow-policy Corp
```

---

# 21

## 21.1

### 21.1.1

IP IP IP

### 21.1.2

IP IP

## 21.2

|  |    |
|--|----|
|  |    |
|  |    |
|  | 60 |

## 21.3

- \_\_\_\_\_
- \_\_\_\_\_
- \_\_\_\_\_

### 21.3.1

---

|               |  |  |
|---------------|--|--|
|               |  |  |
| <b>Step 1</b> | Ruijie# <b>configure terminal</b>        |  |
| <b>Step 2</b> | Ruijie(config)# <b>flow-audit enable</b> |  |
| <b>Step 3</b> | Ruijie(config-if)# <b>end</b>            |  |
| <b>Step 4</b> | Ruijie# <b>show running</b>              |  |

**no flow-audit enable**

#

Ruijie# **configure terminal**

Enter configuration commands, one per line. End with CNTL/Z.

Ruijie(config)# **flow-audit enable**

## 21.3.2

60



---

|  |  |
|--|--|
|  |  |
|--|--|

```
Ruijie# show online statistics{interface
interface-name | bridge bridge-name}
[{detail|recent hour | time-interval begin-year
begin-month begin-day begin-hour to end-year
end-month end-day end-hour}]
```

---

```
show flowrate channel [channel-name  
channel-name] [channel-group channel-group]  
[{recent hour | time-interval begin-year  
begin-month begin-day begin-hour to end-year  
end-month end-day end-hour} | day-interval  
begin-year begin-month begin-day to end-year  
end-month end-day [hour-interval begin-hour to  
end-hour begin-hour2 to end-hour2]] [order-by  
{pass | drop} {upload | download} } {desc |  
asc}[top n]]
```

```
show flowrate interface interface-name  
[{recent hour | time-interval begin-year  
begin-month begin-day begin-hour to end-year  
end-month end-day end-hour} [detail]]
```

```
show flowrate ip {interface interface-name |  
bridge bridge-name} [subscriber-group  
subscriber-group] [{by-group} |[subscriber  
subscriber-name] [ip ip-address] [application  
application-name] [application-group  
application-group] [application-type  
application-type] }[day-interval begin-year  
begin-month begin-day to end-year end-month  
end-day [hour-interval begin-hour1 to  
end-hour1 begin-hour2 to end-hour2]] [order-by  
{pass | drop} {upload | download} | ip |  
subscriber} {desc | asc}[top n] [detail]]
```

```
show flowrate application {interface  
interface-name | bridge bridge-name}  
[subscriber-group subscriber-group]  
[subscriber subscriber-name] [ip
```

---

```
show flowrate ip-application {interface  
interface-name | bridge bridge-name}  
[
```

---

/User\_groupC/User\_nameC

|        |   |         |   |
|--------|---|---------|---|
| 153986 | 0 | 2022024 | 0 |
| 0      | 0 | 0       | 0 |

# gigabitEthernet 0/1

Ruijie#show flowrate application interface gigabitEthernet 0/1

path:GigabitEthernet 0/1

| Application | Subscriber-num |               |             |               |
|-------------|----------------|---------------|-------------|---------------|
| PASS:       | Upload(bps)    | Download(bps) | Upload(pps) | Download(pps) |
| DROP:       | Upload(bps)    | Download(bps) | Upload(pps) | Download(pps) |
| App1        | 46             |               |             |               |
| 62597       | 65955          |               | 15          | 17            |
| 0           | 0              |               | 0           | 0             |

# bridge 0

Ruijie# show flowrate application bridge 0 by-group

path:bridge-map 0

| Application_group |             |               |             |               |
|-------------------|-------------|---------------|-------------|---------------|
| PASS:             | Upload(bps) | Download(bps) | Upload(pps) | Download(pps) |
| DROP:             | Upload(bps) | Download(bps) | Upload(pps) | Download(pps) |
| App_group1        |             |               |             |               |
| 211               | 249         |               | 0           | 0             |
| 0                 | 0           |               | 0           | 0             |

# bridge 0 2010 1 9 2010 1 9

Ruijie# show flowrate application bridge 0 by-group day-interval 2010 1 9 to 2010 1 9

path:bridge-map 0

day-interval: 2010-1-9 ~ 2010-1-9

| Application_group |            |              |                |                  |
|-------------------|------------|--------------|----------------|------------------|
| PASS:             | Upload(KB) | Download(KB) | Upload(packet) | Download(packet) |
| DROP:             | Upload(KB) | Download(KB) | Upload(packet) | Download(packet) |

---

P2P

0 6 24 24

0 0 0 0

/HTTP

5229 116742 59983 89151

0 0 0 0

/ QQ

220 135 1349 1290

0 0 0 0

27684236 159994 363431164 226927

0 0 0 0

# gigabitEthernet 0/1 IP

Ruijie#show flowrate ip-application interface gigabitEthernet 0/1

path:GigabitEthernet 0/1

Subscriber Application

PASS Upload(bps) Download(bps) Upload(pps) Download(pps)

DROP: Upload(bps) Download(bps) Upload(pps) Download(pps)

/user\_groupA/user\_nameA applicationA

46003 2093107 93 173

0 0 0 0

/user\_groupB/user\_nameB applicationB

46001 2093102 193 173

0 0 0 0

/user\_groupC/user\_nameC applicationC

4003 1093107 63 73

0 0 0 0

# bridge 0 2010 1 9

Ruijie# show flowrate ip-application bridge 0 day-interval 2010 1 9 to 2010 1 9

path:bridge-map 0

day-interval: 2010-1-9 ~ 2010-1-9





---

# 22

## 22.1 Ping

Echo  
RGOS Ping Echo

Ping  
Ping Ping

|  |             |
|--|-------------|
|  |             |
| Ruijie# <b>ping</b> [ <i>ip</i> ] [ <i>address</i> ] [ <b>length</b> <i>length</i> ] [ <b>ntimes</b> <i>times</i> ] [ <b>data</b> <i>data</i> ][ <b>source</b> <i>source</i> ] [ <b>timeout</b> <i>seconds</i> ] ] | <b>Ping</b> |

Ping IP 2 5 100Byte  
' ! ' . ' ping

```
Ruijie# ping 192.168.5.1
Sending 5, 100-byte ICMP Echoes to 192.168.5.1, timeout is 2 seconds:
< press Ctrl+C to break >
!!!!
Success rate is 100 percent (5/5), round-trip min/avg/max = 1/2/10
ms
```

Ping Ping Ping  
Ping Ping

Success rate is 100 percent (100/100), round-trip min/avg/max = 2/2/3 ms  
 Ruijie#

## 22.2 Traceroute

### Traceroute Traceroute

```

TTL          0          TTL          1
1           Traceroute          TTL
TTL          1          ICMP          TTL
IP          ICMP TTL

```

### Traceroute

|   |  |
|---|--|
|   |  |
| Ruijie# <b>traceroute</b> [ <i>protocol</i> ] [ <i>destination</i> ]<br>[ <b>probe</b> <i>probe</i> ] [ <i>t</i> <b>tl</b> <i>minimum</i> <i>maximum</i> ]<br>[ <b>source</b> <i>source</i> ] [ <b>time</b> <b>out</b> <i>seconds</i> ] |  |

### Traceroute

1 Traceroute

```

Ruijie# traceroute 61.154.22.36
< press Ctrl+C to break >
Tracing the route to 61.154.22.36

```

```

1    192.168.12.1      0 msec  0 msec  0 msec
2    192.168.9.2      4 msec  4 msec  4 msec
3    192.168.9.1      8 msec  8 msec  4 msec
4    192.168.0.10    4 msec  28 msec 12 msec
5    202.101.143.130  4 msec  16 msec  8 msec
6    202.101.143.154 12 msec  8 msec  24 msec
7    61.154.22.36    12 msec  8 msec  22 msec

```

---

IP 61.154.22.36

1 6

2 Traceroute

Ruijie# **traceroute** 202.108.37.42

< press Ctrl+C to break >

Tracing the route to 202.108.37.42

```
1 192.168.12.1 0 msec 0 msec 0 msec
2 192.168.9.2 0 msec 4 msec 4 msec
3 192.168.110.1 16 msec 12 msec 16 msec
4 * * *
5 61.154.8.129 12 msec 28 msec 12 msec
6 61.154.8.17 8 msec 12 msec 16 msec
7 61.154.8.250 12 msec 12 msec 12 msec
8 218.85.157.222 12 msec 12 msec 12 msec
9 218.85.157.130 16 msec 16 msec 16 msec
10 218.85.157.77 16 msec 48 msec 16 msec
11 202.97.40.65 76 msec 24 msec 24 msec
12 202.97.37.65 32 msec 24 msec 24 msec
13 202.97.38.162 52 msec 52 msec 224 msec
14 202.96.12.38 84 msec 52 msec 52 msec
15 202.106.192.226 88 msec 52 msec 52 msec
16 202.106.192.174 52 msec 52 msec 88 msec
17 210.74.176.158 100 msec 52 msec 84 msec
18 202.108.37.42 48 msec 48 msec 52 msec
```

IP 202.108.37.42

1 17

4

## 22.3 line-detect

|   |  |
|---|--|
|   |  |
| Ruijie(config)# <b>interface</b> <i>interface</i> |  |
| Ruijie(config-if)# <b>line-detect</b>             |  |



AP

```
Ruijie(config)#int gigabitEthernet 3/1
Ruijie(config-if)#line-detect
start cable-diagnoses,please wait...
cable-daignoses end!this is result:
4 pairs
pair state      length(meters)
-----
A      Ok          2
B      Ok          1
C      Short        1
D      Short        1
```

| pairs | State | Open | OK | Short    | OK |
|-------|-------|------|----|----------|----|
|       |       | C D  | q  | A B BC D |    |

OK

# 23 DHCP

## 23.1 DHCP

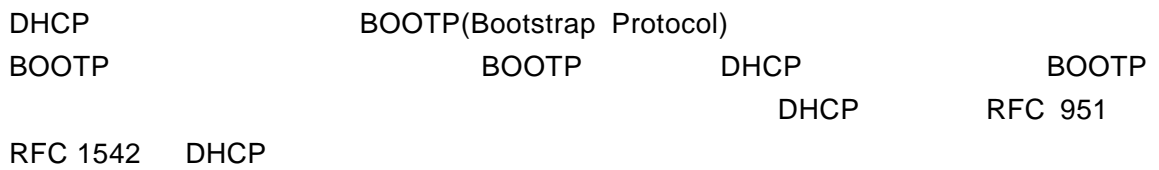
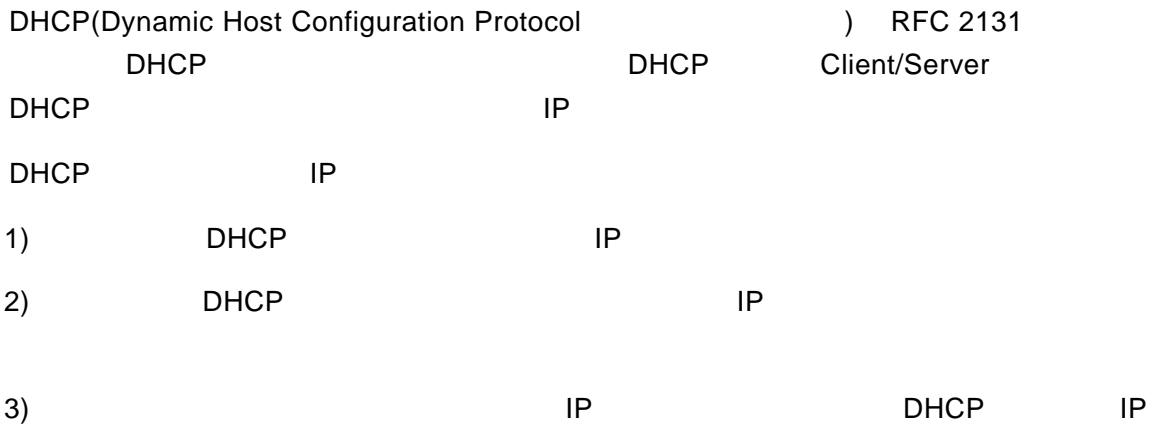

## 23.2 DHCP

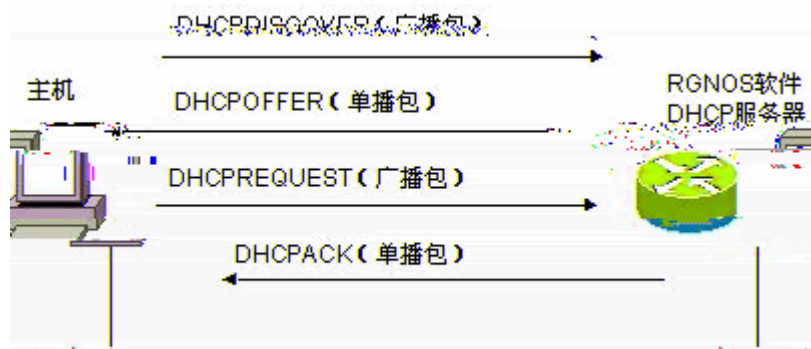
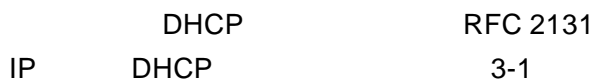

1 DHCP



- 1) DHCPDISCOVER DHCP
- 2) DHCP DHCPOFFER IP MAC
- 3) DHCPREQUEST IP
- 4) DHCP DHCPACK



DHCP DHCP DHCPOFFER  
DHCPOFFER DHCPOFFER

DFER



FR PPP HDLC DHCP

## 23.4 DHCP

DHCP DHCP DHCP DHCP DHCP  
DHCP DHCP DHCP DHCP  
DHCP IP DHCP DHCP  
DHCP  
DHCP DHCP DHCP DHCP DHCP  
DHCP

## 23.5 DHCP

- DHCP
- DHCP
- DHCP
- DHCP
-

DHCP

|            |      |      |
|------------|------|------|
| Ruijie(con | DHCP | DHCP |
| Ruijie(con | DHCP |      |



1 CP DHCP **service dhcp**  
DHCP  
10. s  
10. CP

### 23.5.2 DHCP



- DHCP
- DHCP
- DHCP
- DHCP
- DHCP
- DHCP
- DHCP
- DHCP
- NetBIOS WINS
- NetBIOS

### 23.5.3.1

|  |  |
|--|--|
|  |  |
| Ruijie(config)# <b>ip dhcp pool</b> <i>dhcp-pool</i> |  |

“Ruijie(dhcp-config)#”

### 23.5.3.2

DHCP

|   |  |
|---|--|
|   |  |
| Ruijie (dhcp-config)# <b>bootfile</b> <i>filename</i> |  |

### 23.5.3.3

DHCP

IP

IP

| Ruijie(dhcp-config)# <b>default-router</b> <i>address</i><br>[ <i>address2...address8</i> ] |  |
|---|--|

### 23.5.3.4

|   |     |
|---|-----|
| Ruijie(dhcp-config)# <b>dns-server</b> <i>address</i><br>[ <i>address2...address8</i> ] | DNS |
|---|-----|

### 23.5.3.7 NetBIOS WINS



## DHCP

:

|   |      |
|---|------|
|   |      |
| Ruijie(dhcp-config)# <b>network</b><br><i>network-number mask</i> | DHCP |



DHCP ID  
DHCP  
[  
]

### 23.5.4

IP MAC 1  
DHCP IP MAC DHCP  
IP 2 IP MAC  
IP MAC DHCP  
IP MAC  
MAC RFC 1700 "Address Resolution Protocol  
Parameters" "01"

|  |  |
|--|--|
|  |  |
|--|--|

|  |                                  |
|--|----------------------------------|
| Ruijie(dhcp-config)# <b>hardware-address</b><br><i>hardware-address type</i> | aabb.bbbb.bb88                   |
| Ruijie(dhcp-config)# <b>client-identifier</b><br><i>unique-identifier</i>    | 01aa.bbbb.bbbb.88                |
| Ruijie(dhcp-config)# <b>client-name</b> <i>name</i>                          | ASCII<br><br>mary<br>mary.rg.com |

### 23.5.5 Ping

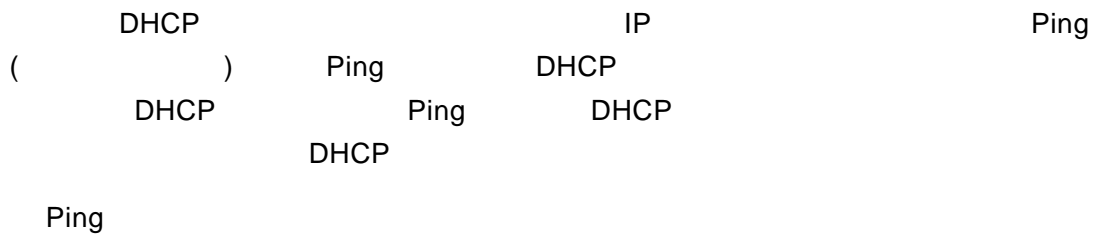

|   |                          |
|---|--------------------------|
| Ruijie(config)# <b>ip dhcp ping</b><br><b>packets</b> <i>number</i> | DHCP<br>Ping 0<br>Ping 2 |
|---|--------------------------|

### 23.5.6 Ping



|   |                    |
|---|--------------------|
| Ruijie(config)# <b>ip dhcp ping</b><br><b>timeout</b> <i>milliseconds</i> | DHCP Ping<br>500ms |
|---|--------------------|

### 23.5.7 DHCP



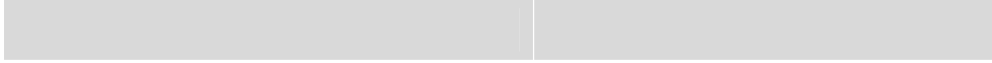





|              | MAC           | 00d0.df34.32a3 | DHCP         | IP           |
|--------------|---------------|----------------|--------------|--------------|
| 172.16.1.101 | 255.255.255.0 |                | Billy.rg.com | 172.16.1.254 |
| WINS         | 172.16.1.252  | NetBIOS        |              |              |

```
ip dhcp pool Billy
host 172.16.1.101 255.255.255.0
hardware-address 00d0.df34.32a3 ethernet
client-name Billy
default-router 172.16.1.254
domain-name rg.com
dns-server 172.16.1.253
netbios-name-server 172.16.1.252
netbios-node-type h-node
```

### 23.7.3 DHCP

GigabitEthernet 0/0      DHCP

```
interface GigabitEthernet0/0
ip address dhcp
```

# 24 DHCP Relay

## 24.1

### 24.1.1 DHCP

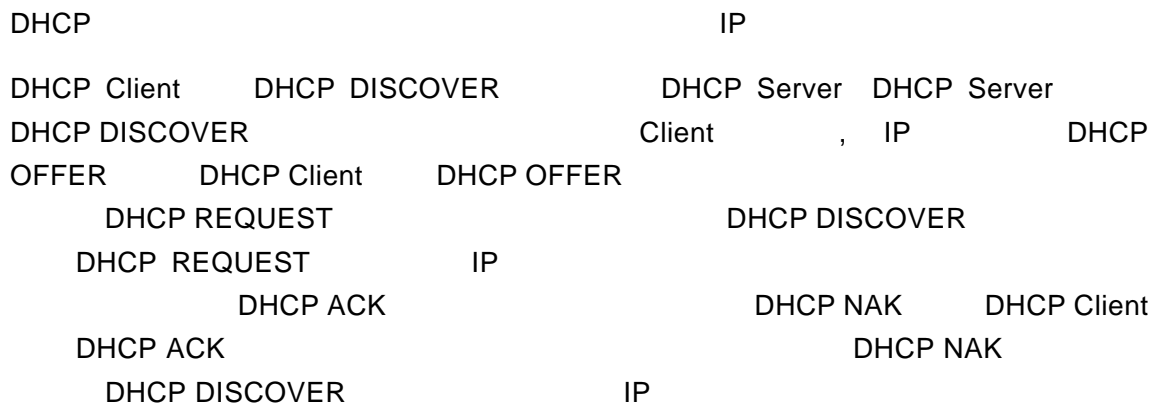

### 24.1.2 DHCP DHCP Relay Agent

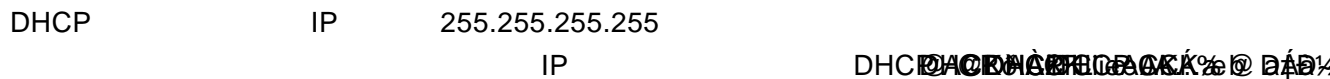

1

|             |          |             |                  |             |
|-------------|----------|-------------|------------------|-------------|
| VLAN 10     | VLAN 20  | 10.0.0.1/16 | 20.0.0.1/16      | DHCP Server |
| 30.0.0.1/16 | 30.0.0.2 | DHCP Server | 10.0.0.1/16      | 20.0.0.1/16 |
|             | IP       |             | DHCP Relay Agent | DHCP Server |
| IP          | 30.0.0.2 |             |                  |             |

### 24.1.3 DHCP Relay Agent Information(option 82)

|           |             |            |        |        |   |   |
|-----------|-------------|------------|--------|--------|---|---|
| RFC3046   |             | DHCP relay |        | option |   |   |
|           | DHCP client |            |        |        |   |   |
|           | IP          | RFC3046    | option | 82     |   |   |
| option82I |             | R          | e      | m      | o | t |

**Circuit ID**

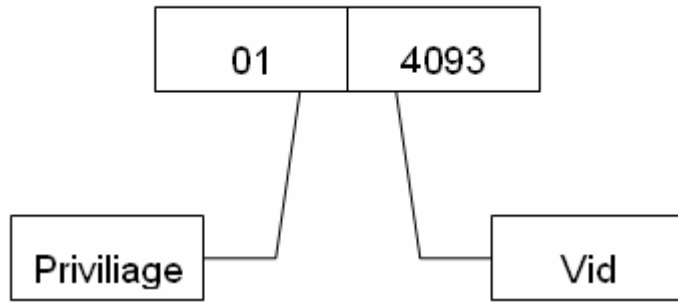

2

- 2. relay agent information option82      option
- DHCP relay                                  DHCP
- option82                              option

**Agent Circuit ID**

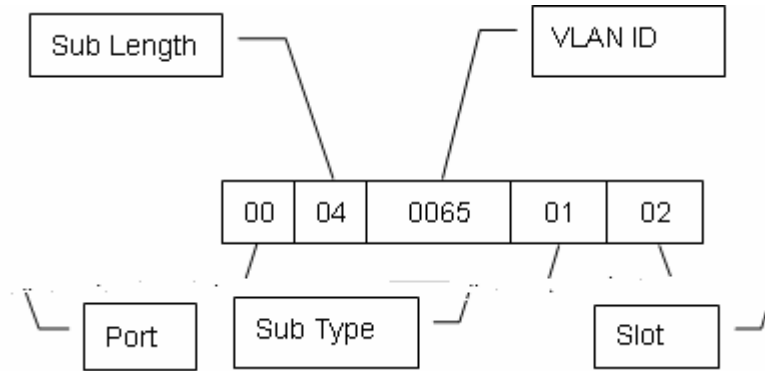

3

**Agent Remote ID**

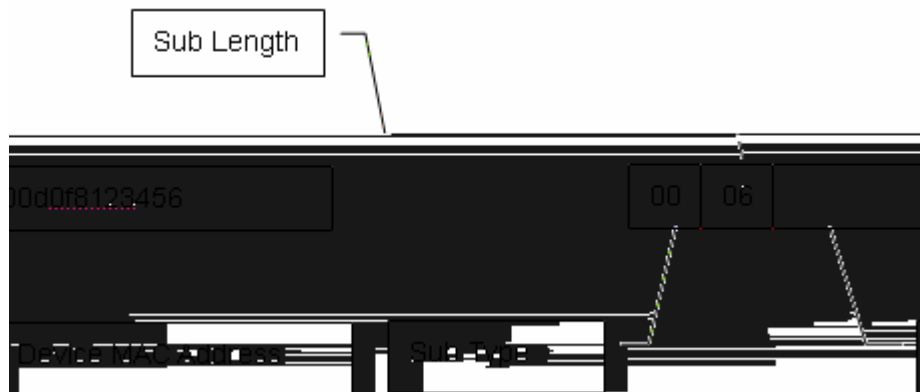

4

**24.1.4 DHCP relay Check Server-id**

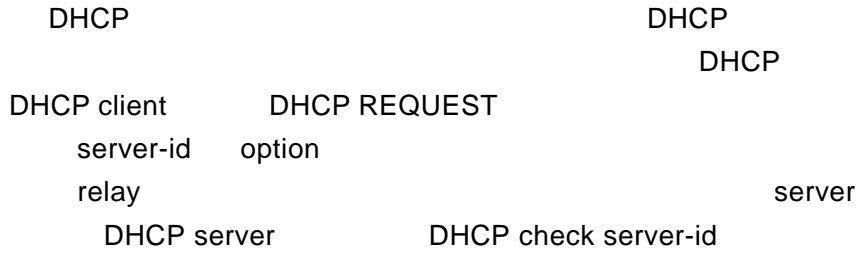

## 24.2 DHCP

### 24.2.1 DHCP

DHCP

| Ruijie (config)# <b>service dhcp</b>   | DHCP |
|--|------|
| Ruijie(config)# <b>no service dhcp</b> | DHCP |

### 24.2.2 DHCP Server IP

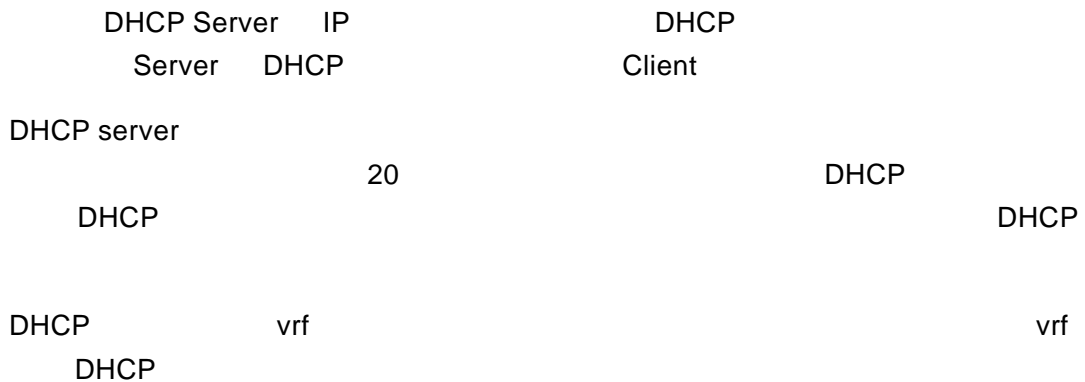

| Ruijie(config)# <b>IP helper-address [vrf] A.B.C.D</b>    | DHCP |
|---|------|
| Ruijie(config-if)# <b>IP helper-address [vrf] A.B.C.D</b> | DHCP |
| Ruijie(config)# <b>no IP helper-address [vrf] A.B.C.D</b> | DHCP |

|  |      |
|--|------|
| Ruijie(config-if)# <b>no IP helper-address</b><br>[vrf] <i>A.B.C.D</i> | DHCP |
|--|------|

### 24.2.3 DHCP option dot1x

DHCP Relay Agent Information

```
Ruijie(config-ext-nacl)# permit ip any host 192.168.5.1
Ruijie(config-ext-nacl)# permit ip host 192.168.3.1 any
//      IP
Ruijie(config-ext-nacl)# permit ip host 192.168.4.1 any
Ruijie(config-ext-nacl)# permit ip host 192.168.5.1 any
Ruijie(config-ext-nacl)# deny ip 192.168.3.0 0.0.0.255 192.168.3.0
0.0.0.255
//
Ruijie(config-ext-nacl)# deny ip 192.168.3.0 0.0.0.255 192.168.4.
0 0.0.0.255
Ruijie(config-ext-nacl)# deny ip 192.168.3.0 0.0.0.255 192.168.5.
0 0.0.0.255
Ruijie(config-ext-nacl)# deny ip 192.168.4.0 0.0.0.255 192.168.4.
0 0.0.0.255
Ruijie(config-ext-nacl)# deny ip 192.168.4.0 0.0.0.255 192.168.5.
0 0.0.0.255
Ruijie(config-ext-nacl)# deny ip 192.168.5.0 0.0.0.255 192.168.5.
0 0.0.0.255
Ruijie(config-ext-nacl)# deny ip 192.168.5.0 0.0.0.255 192.168.3.
0 0.0.0.255
Ruijie(config-ext-nacl)# deny ip 192.168.5.0 0.0.0.255 192.168.4.
0 0.0.0.255
Ruijie(config-ext-nacl)# exit
```

**ip dhcp relay information option dot1x access-group**

*DenyAccessEachOtherOfUnauthrize*

**DHCP option dot1x access-group** e

DHCP option82

| Ruijie(config)# <b>ip dhcp relay information option82</b>    | DHCP option82 |
|--|---------------|
| Ruijie(config)# <b>no ip dhcp relay information option82</b> | DHCP option82 |

### 24.2.6 DHCP relay check server-id

**ip dhcp relay check server-id** DHCP SERVER-ID option DHCP relay server

DHCP relay check server-id

| Ruijie(config)# <b>ip dhcp relay check server-id</b>    | DHCP relay check server-id |
|---|----------------------------|
| Ruijie(config)# <b>no ip dhcp relay check server-id</b> | DHCP relay check server-id |

### 24.2.7 DHCP relay suppression

**ip dhcp relay suppression** DHCP relay DHCP relay suppression

| Ruijie(config-if)# <b>ip dhcp relay suppression</b>    | DHCP relay suppression |
|--|------------------------|
| Ruijie(config-if)# <b>no ip dhcp relay suppression</b> | DHCP relay suppression |

### 24.2.8 DHCP

```

                dhcp relay
Ruijie# configure terminal
Ruijie(config)# service dhcp // dhcp relay
Ruijie(config)# ip helper-address 192.18.100.1 //
Ruijie(config)# ip helper-address 192.18.100.2 //
Ruijie(config)# interface GigabitEthernet 0/3
Ruijie(config-if)# ip helper-address 192.18.200.1 //

Ruijie(config-if)# ip helper-address 192.18.200.2 //

Ruijie(config-if)# end

```

## 24.3 DHCP relay

```

                option82                vlan relay                option dot1x
                option82                vlan relay

```

### 24.3.1 DHCP option dot1x

```

1.                AAA/802.1x
2.                802.1x  DHCP  IP
3.                dhcp option82
4.                802.1x  DHCP  IP                MAC + IP
                DHCP

```

### 24.3.2 DHCP option82

```

DHCP option82                dhcp option dot1x

```

## 24.4 DHCP

```

                show running-config                DHCP

Ruijie# show running-config
Building configuration...
Current configuration : 1464 bytes
version RG0S 10.1.00(1), Release(11758)(Fri Mar 30 12:53:11 CST 2007
-nprd

```

```
hostname Ruijie
vlan 1
ip helper-address 192.18.100.1
ip helper-address 192.18.100.2
ip dhcp relay information option dot1x
interface GigabitEthernet 0/1
interface GigabitEthernet 0/2
interface GigabitEthernet 0/3
no switchport
ip helper-address 192.168.200.1
ip helper-address 192.168.200.2
interface VLAN 1
ip address 192.168.193.91 255.255.255.0
line con 0
exec-timeout 0 0
line vty 0
exec-timeout 0 0
login
password 7 0137
line vty 1 2
login
password 7 0137
line vty 3 4
login
end
```

## 24.5 DHCP

### 24.5.1 IP

#### 24.5.1.1

|   |    |
|---|----|
| 1 | IP |
| 2 | IP |

24.5.1.2

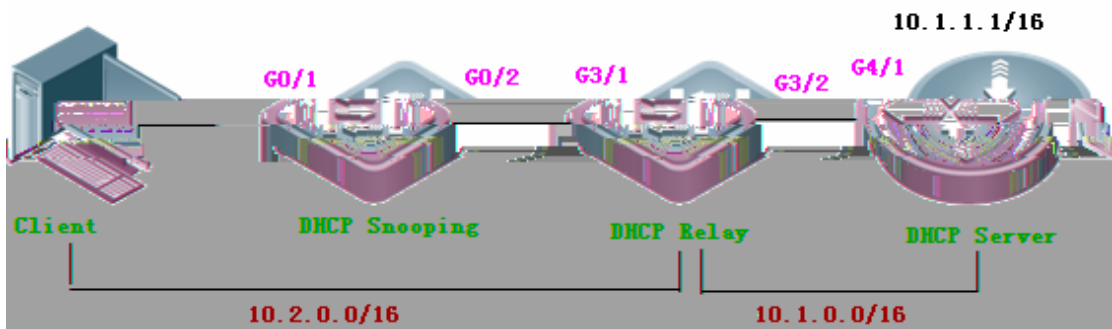

24.5.1.3

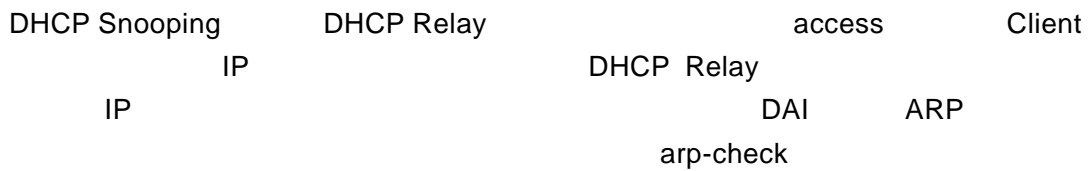

24.5.1.4

- DHCP Snooping

```
# DHCP Snooping
Ruijie(config)# ip dhcp snooping

# Gi0/2
Ruijie(config)# interface gigabitEthernet 0/2
Ruijie(config-if)# ip dhcp snooping trust

# Gi0/2 ARP
Ruijie(config-if)# ip arp inspection trust
Ruijie(config-if)# exit

# VLAN DAI
Ruijie(config)# ip arp inspection vlan 1

# IP SVI1
Ruijie(config)# interface vlan 1
Ruijie(config-if)# ip address 10.2.0.1 255.255.0.0

# 10.1.0.0/16
```

```
Ruijie(config)# ip route 10.1.0.0 255.255.0.0 10.2.1.1
```

- DHCP Relay

```
# DHCP
```

```
Ruijie(config)# server dhcp
```

```
# DHCP
```

```
Ruijie(config)# ip helper-address 10.1.1.1
```

```
# Snooping IP
```

```
Ruijie(config)# interface gigabitEthernet 3/1
```

```
Ruijie(config-if)# no switchport
```

```
Ruijie(config-if)# ip address 10.2.1.1 255.255.0.0
```

```
# Server IP
```

```
Ruijie(config)# interface gigabitEthernet 3/2
```

```
Ruijie(config-if)# no switchport
```

```
Ruijie(config-if)# ip address 10.1.0.1 255.255.0.0
```

- DHCP Server

```
# Relay IP
```

```
Ruijie(config)# interface gigabitEthernet 4/1
```

```
Ruijie(config-if)# no switchport
```

```
Ruijie(config-if)# ip address 10.1.1.1 255.255.0.0
```

```
# DHCP
```

```
Ruijie(config)# service dhcp
```

```
# DHCP
```

```
Ruijie(config)# ip dhcp excluded-address 10.1.1.1 10.1.1.10
```

```
#
```

```
Ruijie(config)# ip dhcp pool linwei
```

```
#
```

```
Ruijie(dhcp-config)# default-router 10.2.1.1
```

```
# DHCP
```

```
Ruijie(dhcp-config)# network 10.2.0.0 255.255.0.0
```

```
# 10.2.0.0/16
```

```
Ruijie(config)# ip route 10.2.0.0 255.255.0.0 10.1.0.1
```

# 25 DNS

## 25.1 DNS

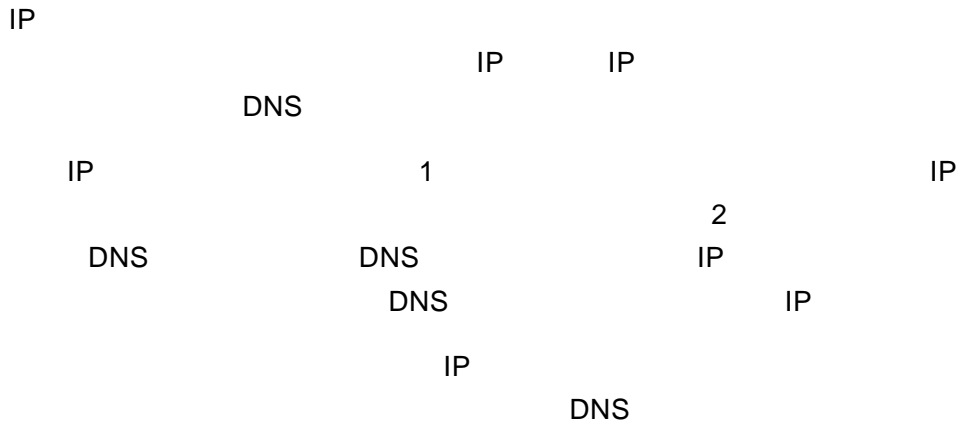

## 25.2

### 25.2.1 DNS

DNS

|        |   |
|--------|---|
|        |   |
| DNS    |   |
| DNS IP |   |
|        |   |
| DNS    | 6 |

### 25.2.2 DNS

DNS

|  |  |
|--|--|
|  |  |
|--|--|

|   |     |
|---|-----|
| Ruijie(config)# <b>ip<br/>Domain-lookup</b> | DNS |
|---|-----|

**no ip domain-lookup**          DNS

Ruijie(config)# **ip domain-lookup**

### 25.2.3          DNS Server

DNS

DNS

DNS

**no ip name-server** [*ip-address*]

**ip-address**

|   |  |
|---|--|
|   |  |
| Ruijie(config)# <b>ip<br/>name-server</b> <i>ip-address</i> | DNS Server    IP<br>DNS Server<br>Server<br>Server          DNS<br>6 |

### 25.2.4

### IP

|                                     |  |
|-------------------------------------|--|
| Ruijie# <b>clear host</b><br>[word] |  |
|-------------------------------------|--|

## 25.2.6

### DNS

|                           |     |
|---------------------------|-----|
|                           |     |
| Ruijie# <b>show hosts</b> | DNS |

```
Ruijie# show hosts
DNS name server   :
192.168.5.134    static
      host                type                address
www.163.com      static          192.168.5.243
www.ruijie.com   dynamic         192.168.5.123
```

## 25.2.7

### Ping

```
Ruijie# ping www.ietf.org
Resolving host[www.ietf.org]
Sending 5,100-byte ICMP Echos to 192.168.5.123,
timeout is 2000 milliseconds.
!!!!
Success rate is 100 percent(5/5)
Minimum = 1ms Maximum = 1ms, Average = 1ms
```

# 26 NTP

## 26.1 NTP

Network Time Protocol NTP

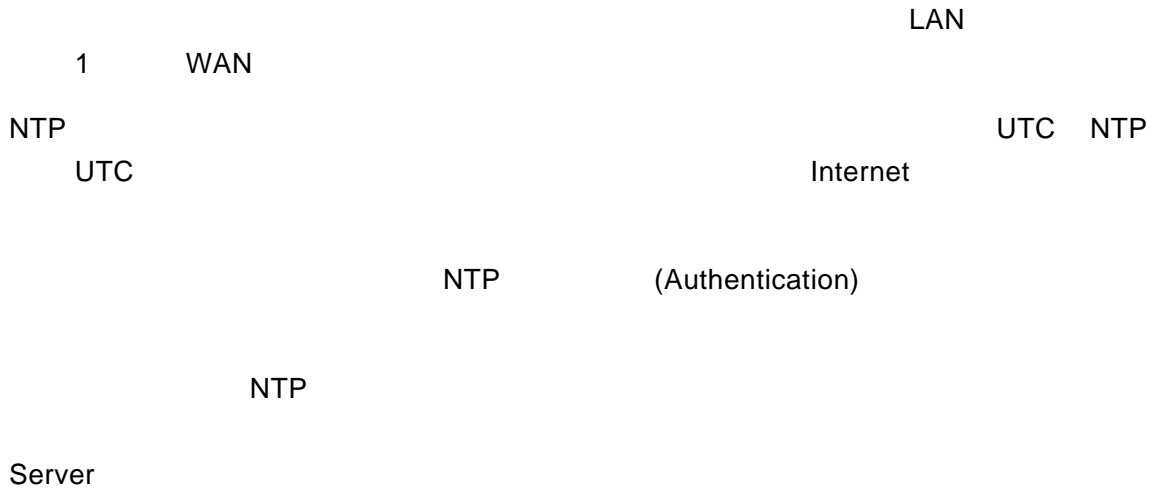

## 26.2 NTP

- NTP
- NTP
- NTP ID
- NTP
- NTP
- NTP
- NTP
- NTP
- NTP
- NTP

### 26.2.1 NTP





1024



### 26.2.3 NTP ID

| <code>ntp trusted-key key-id</code>    | NTP | ID |
|--|-----|----|
| <code>no ntp trusted-key key-id</code> | NTP | ID |

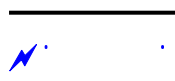

### 26.2.4 NTP

NTP

20 NTP

NTP 3  
NTP

NTP

NTP

|  |  |
|--|--|
|  |  |
|--|--|

|  |  |
|--|--|
| <p><b>ntp server</b> <i>ip-addr</i> [<b>version</b> <i>version</i>][ <b>source</b> <i>if-name</i> <i>number</i>][<b>key</b> <i>keyid</i>][<b>prefer</b>]</p> | <p>NTP<br/>           version NTP 1-3<br/>           if-name<br/>           Aggregateport Dialer<br/>           GigabitEthernet Loopback Multilink<br/>           Null Tunnel Virtual-ppp<br/>           Virtual-template Vlan<br/>           keyid 1-4294967295</p> |
| <p><b>no ntp server</b> <i>ip-addr</i></p>   | <p>NTP</p>   |

## 26.2.5

## NTP

NTP

NTP

NTP



IP

NTP



NTP

|  |     |
|--|-----|
|  |     |
| <b>no ntp</b>  | NTP |
| <b>ntp authenticate</b><br><b>ntp server</b> <i>ip-addr</i> [ <b>version</b><br><i>version</i> ][ <b>source</b> <i>if-name number</i> ][ <b>key</b><br><i>keyid</i> ][ <b>prefer</b> ] | NTP |

**26.2.7 NTP**

8

NTP

1

NTP

|  |        |
|--|--------|
|  | svsR70 |
|--|--------|

|                                     |  |
|-------------------------------------|--|
| <code>no ntp update-calendar</code> |  |
|-------------------------------------|--|

NTP

NTP

## 26.2.9 NTP

NTP

---

 .

|     |   |         |   |   |       |   |
|-----|---|---------|---|---|-------|---|
| NTP | " | stratum | " | " | hops  | " |
|     | 1 |         |   | 2 |       |   |
| 1   |   | 3       |   | 2 | ..... |   |

NTP

|                                   |               |
|-----------------------------------|---------------|
|                                   |               |
| <code>ntp master [stratum]</code> | NTP<br>1 15 8 |
| <code>no ntp master</code>        | NTP           |

12

Ruijie(config)# `ntp master 12`



ntp

NTP

---

## 26.2.10 NTP

NTP

NTP

NTP

NTP

| <b>ntp access-group { peer   serve  <br/>serve-only   query-only }</b><br><i>access-list-number access-list-name</i>    |  |
|---|--|
| <b>no ntp access-group { peer   serve  <br/>serve-only   query-only }</b><br><i>access-list-number access-list-name</i> |  |

- **peer** NTP
- **serve** NTP
- **serve-only** NTP
- **query-only** NTP
- *access-list-number* IP 1 99 1300 1999  
IP
- *access-list-name* IP IP

NTP

peer serve serve-only query-only



NTP

```
Ruijie# show ntp status
```

```
Clock is synchronized, stratum 9, reference is 192.168.217.100  
nominal freq is 250.0000 Hz, actual freq is 250.0000 Hz, precision  
is 2**18  
reference time is AF3CF6AE.3BF8CB56 (20:55:10.000 UTC Mon Mar 1 1993)  
clock offset is 32.97540 sec, root delay is 0.00000 sec  
root dispersion is 0.00003 msec, peer dispersion is 0.00003 msec
```

| starum          | reference      | frep            |
|-----------------|----------------|-----------------|
| precision       | reference time | UTC             |
| clock offset    | root delay     | root dispersion |
| peer dispersion |                |                 |

## 26.4

```
key-id 6 key-string woooooop  
master NTP  
NTP  
NTP  
NTP
```

IPv4

```
Ruijie(config)# no ntp  
Ruijie(config)# ntp authentication-key 6 md5 woooooop  
Ruijie(config)# ntp authenticate  
Ruijie(config)# ntp trusted-key 6  
Ruijie(config)# ntp server 192.168.210.222 key 6  
Ruijie(config)# interface git6(e(c)6(on)6(.23 0 t0228 Tf00tf0 9.314 0 m( -
```

## **27**

## **(SNTP)**

### **27.1**

T2 ( ) Receive Timestamp  
T3 ( ) Transmit Timestamp  
T4 ( ) Destination  
Timestamp  
T  
d

$$T2 = T1 + t + d / 2;$$

$$T2 - T1 = t + d / 2;$$

$$T4 = T3 - t + d / 2;$$

$$T3 - T4 = t - d / 2;$$

$$d = (T4 - T1) - (T3 - T2);$$

$$t = ((T2 - T1) + (T3 - T4)) / 2;$$

t d SNTP Client

T4 + t

## 27.2 SNTP

SNTP

### 27.2.1 SNTP

SNTP

|      |              |
|------|--------------|
|      |              |
| SNTP | Disable SNTP |

|               |       |
|---------------|-------|
| NTP Server IP | 0     |
| SNTP          | 1800s |
|               | +8    |

## 27.2.2 SNTP

### SNTP

1)

```
Ruijie# config
```

2) SNTP " " " 5 )  
( " " " 5 )

```
Ruijie(config)# sntp enable
```

3)

```
Ruijie(config)# End
```

4)

```
Ruijie# show running-config
```

5)

```
Ruijie# copy running-config startup-config
```

SNTP

**no sntp enable**

SNTP

(SNTP)

---

2) SNTP Server IP

```
SNTP                                     (GMT)

1
Ruijie# config

2          -23  23                        8      -8
          8    0

Ruijie(config)# clock time-zone <time-zone>

3
Ruijie(config)# End

4
Ruijie# show running-config

5
Ruijie# copy running-config startup-config

          no clock time-zone
```

## 27.3 SNTP

### 1) SNTP

```
Ruijie# show sntp
```

### 2) show sntp

```
Ruijie# show sntp
SNTP state           : ENABLE           //SNTP
SNTP server          : 192.168.4.12     //NTP Server
SNTP sync interval   : 60              //
Time zone            : +8                //
```

## 28 SSH

### 28.1 SSH

SSH      Secure Shell      SSH      Telnet  
 Telnet  
                                  SSH  
                                  IP

### 28.2 SSH

|  | SSH1              | SSH2   |
|--|-------------------|--|
|  | RSA               | RSA DSA  |
|  | RSA               | KEX_DH_GEX_SHA1<br>KEX_DH_GRP1_SHA1<br>KEX_DH_GRP14_SHA1 |
|  | DES 3DES Blowfish | DES 3DES AES-128<br>AES-192 AES-256                      |
|  |                   |  |
|  |                   | MD5 SHA1 SHA1-96<br>MD5-96                               |
|  | NONE              | NONE   |

### 28.3 SSH



SSH

SSHv1

SSHv2

SSH

### 28.4 SSH

## 28.4.1 SSH

|     |      |
|-----|------|
|     |      |
| SSH |      |
| SSH | 1 2  |
| SSH | 120s |
| SSH | 3    |

## 28.4.2

- SSH  
Telnet
- (Username) (Password)

## 28.4.3 SSH Server

SSH Server                      SSH Server  
**enable service ssh-server**                      SSH                      SSH Server  
 ENABLE

|                                      |            |
|--------------------------------------|------------|
|                                      |            |
| <b>configure terminal</b>            |            |
| <b>enable service ssh-server</b>     | SSH Server |
| <b>crypto key generate {rsa dsa}</b> |            |



[no] crypto key generate                      crypto key zeroize

## 28.4.4 SSH Server

SSH Server                      **no enable service ssh-server**  
 SSH Server                      DISABLE

|                                     |            |
|-------------------------------------|------------|
|                                     |            |
| <b>configure terminal</b>           |            |
| <b>no enable service ssh-server</b> | SSH Server |

### 28.4.5 SSH server

SSH Server                      1   2                      SSH

|                               |                      |
|-------------------------------|----------------------|
|                               |                      |
| <b>configure terminal</b>     |                      |
| <b>ip ssh version {1   2}</b> | SSH                  |
| <b>no ip ssh version</b>      | SSH<br>SSHv1   SSHv2 |

### 28.4.6 SSH

SSH Server    120    SSH

|                                    |                 |
|------------------------------------|-----------------|
|                                    |                 |
| <b>configure terminal</b>          |                 |
| <b>ip ssh time-out <i>time</i></b> | SSH<br>1-120sec |
| <b>no ip ssh time-out</b>          | SSH<br>120      |

### 28.4.7 SSH

SSH  
SSH Server    3  
SSH

|                           |  |
|---------------------------|--|
|                           |  |
| <b>configure terminal</b> |  |

|   |            |
|---|------------|
| <b>ip ssh authentication-retries</b> <i>retry times</i> | SSH<br>0-5 |
| <b>no ip ssh authentication-retries</b>                 | SSH<br>3   |

[SSH ]

## 28.5 SSH

SSH Windows Telnet SSH Server  
Putty Linux SecureCRT  
SecureCRT SSH

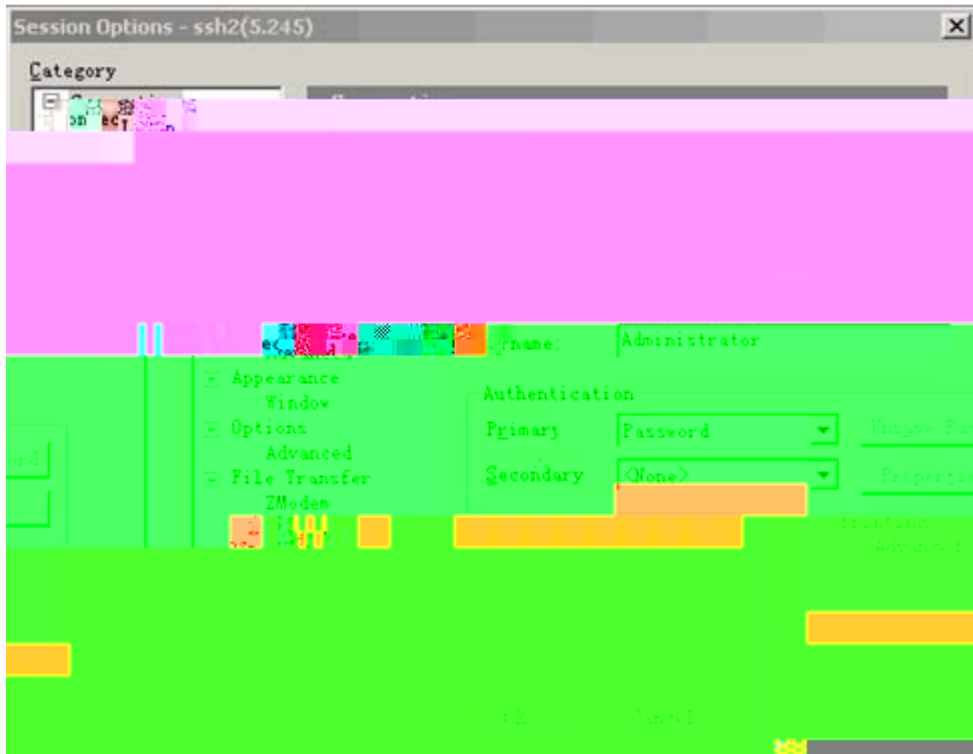

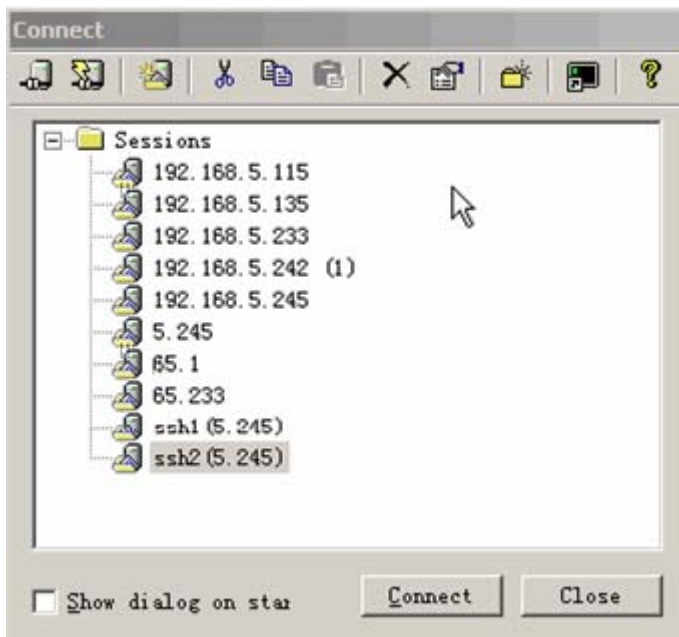

2

Connect

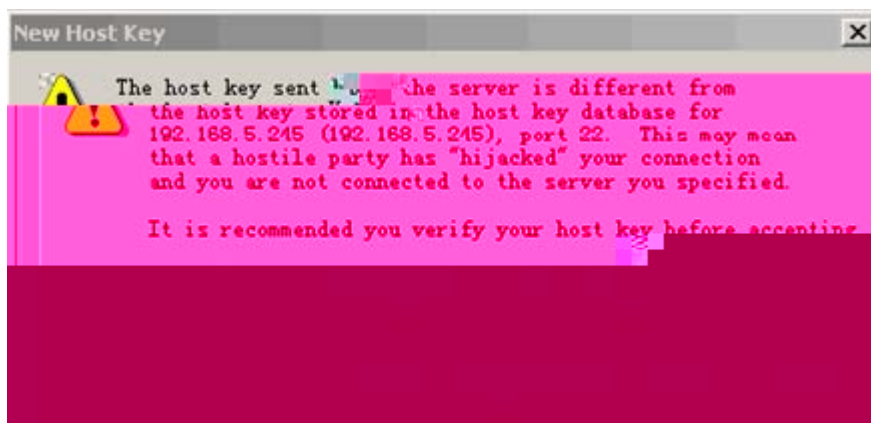

3

4

Telnet

Telnet



5

# 29 UDP-Helper

## 29.1 UDP-Helper

### 29.1.1 UDP-Helper

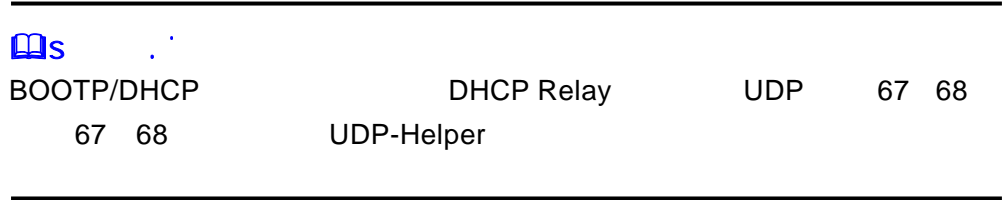
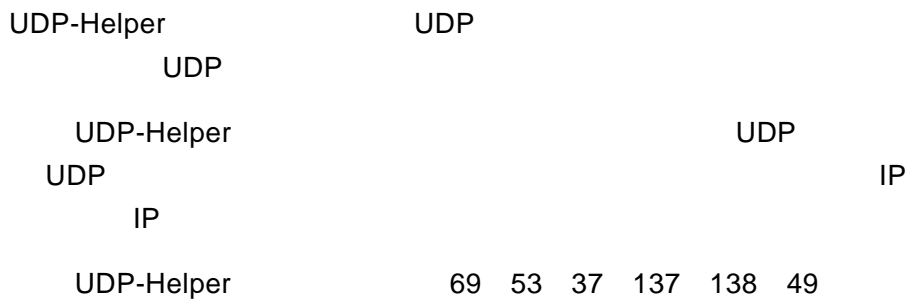

## 29.2 UDP-Helper

### 29.2.1 UDP-Helper

|     |                                       |
|-----|---------------------------------------|
|     |                                       |
|     |                                       |
| UDP | UDP-Helper 69<br>53 37 137 138 49 UDP |
|     |                                       |

### 29.2.2 UDP-Helper

|  |  |
|--|--|
|  |  |
| Ruijie(config)# <b>udp-helper enable</b> | <b>udp-helper enable</b><br>UDP<br>UDP |

**no udp-helper enable**

UDP



1)

2) UDP 69 53 37 137 138 49 UDP

3) DUP UDP

### 29.2.3

|  |     |
|--|-----|
|  |     |
| Ruijie(config-if)# <b>ip helper-address</b><br><i>IP-Address</i> | UDP |

**no ip helper-address**



1) 20

2) UDP-Helper

UDP

### 29.2.4

**UDP**

|  |  |
|--|--|
|  |  |
|--|--|

|   |   |
|---|---|
| <pre>Ruijie(config)# ip forward-protocol udp ID</pre> | <pre>UDP UDP UDP-Helper 69 53 37 137 138 49</pre> |
|---|---|

no ip forward-protocol udp port  
4

UDP



- UDP-Helper  
UDP

SyYz+Saw L@SÔ



---

# 30

IP

1

:

1.

| Ruijie(config)# <b>route-map</b> <i>route-map-name</i><br><b>[permit   deny]</b> <i>sequence</i>         |  |
|--|--|
| Ruijie(config)# <b>no</b> <b>route-map</b><br><i>route-map-name</i><br><b>{[permit   deny] sequence}</b> |  |

2.

| Ruijie(config-route-map)# <b>match ip address</b><br><i>access-list-number</i> |  |
|--|--|
| Ruijie(config-route-map)# <b>match length</b> <i>min</i><br><i>max</i>         |  |

3.

|   |         |
|---|---------|
| Ruijie(config-route-map)# <b>set ip default next-hop</b><br><i>ip-address [weight][ip-address [weight]]</i> | IP      |
| Ruijie(config-route-map)# <b>set ip next-hop</b><br><i>ip-address [weight][ip-address [weight]]</i>         | IP      |
| Ruijie(config-route-map)# <b>set interface</b><br><i>intf_name</i>  |         |
| Ruijie(config-route-map)# <b>set default interface</b> <i>intf_name</i>                                     |         |
| Ruijie(config-route-map)# <b>set ip precedence</b>  | IP      |
| Ruijie(config-route-map)# <b>set ip tos</b>   | IP TOS  |
| Ruijie(config-route-map)# <b>set ip dscp</b>  | IP DSCP |

4.

, :

|   |           |
|---|-----------|
|   |           |
| Ruijie(config-if)# <b>ip policy route-map</b> <i>name</i> | route-map |
| Ruijie(config-if)# <b>no ip policy route-map</b>          | route-map |

5.

|  |           |
|--|-----------|
|  |           |
| Ruijie(config-if)# <b>ip local policy route-map</b><br><i>[name]</i> | route-map |
| Ruijie(config-if)# <b>no ip local policy route-map</b>               |           |

:

GigabitEthernet 0/0 ,  
192.168.5.5  
Ruijie(config)# **access-list 1 permit any**

---

```
Ruijie(config)# route-map name
Ruijie(config-route-map)# match ip address 1
Ruijie(config-route-map)# set ip next-hop 192.168.5.5
Ruijie(config-route-map)# int GigabitEthernet 0/0
Ruijie(config-if)# ip policy route-map name
```

| Ruijie(config)# <b>ip policy {load-balance   Redundance}</b> |  |
|--|--|
| Ruijie(config)# <b>no ip</b>                                 |  |

---

---

# 31

## 31.1

### 31.1.1

### 31.1.2

ISP

IP

IP

IP

---

## 31.3

- \_\_\_\_\_
- \_\_\_\_\_

### 31.3.1

---

#

## 32 RIP

### 32.1 RIP

RIP (Routing Information Protocol)

RIP

RIPv1

RFC 1058

- 
- RIP
- RIP
- RIP
- RIP
- RIP VRF ( )  
IP “ ”
- 
- 
- 

### 32.2.1 RIP

RIP

RIP

RIP

RIP

|  |     |
|--|-----|
|  |     |
| Ruijie(config)# <b>router rip</b>  | RIP |
| Ruijie(config-router)# <b>network</b> <i>network-number</i><br><i>wildcard</i> |     |

*network-number* *wildcard*

RIP

*wildcard* RGOS  
RIP



#### network

- 1 RIP
- 2 RIP

RIP

RIP

RIP

RIP

RIP

|   |     |
|---|-----|
|   |     |
| Ruijie(conf-router)# <b>neighbor</b> ip-address | RIP |

RIP

**passive-interface**

" "



FR X.25

Broadcast

**neighbor**

**Neighbor**

### 32.2.3

IP

X.25

IP

|   |  |
|---|--|
|   |  |
| Ruijie(config-if)# <b>no ip split-horizon</b> |  |
| Ruijie(config-if)# <b>ip split-horizon</b>    |  |

### 32.2.4 RIP

VLMSs

RIP

1

2

RIPv2

VLMSs

CIDR



## RIP

| Ruijie(config-router)# <b>no auto-summary</b> |  |
|---|--|
| Ruijie(config-router)# <b>auto-summary</b>    |  |

| Ruijie(config-if)# <b>ip summary-address rip</b><br><i>ip-address ip-network-mask</i>              |  |
|--|--|
| Ruijie(config-if)# <b>no ip summary-address</b><br><b>rip</b><br><i>ip-address ip-network-mask</i> |  |

### 32.2.6 RIP

RIPv1

RIPv2

RIPv2

MD5

**ip rip authentication text-password**

MD5

MD5

|   |  |
|---|--|
| Ruijie(config-if)# <b>ip rip authentication</b><br><b>key-chain</b> <i>key-chain-name</i> |  |
|---|--|

### 32.2.7 RIP

RIP

RIP

RIP

RIP

|  |     |
|--|-----|
|  |     |
| Ruijie(config-router)# <b>timers basic</b> <i>update</i><br><i>invalid flush</i> | RIP |

30                      180                      120



RIP

### 32.2.8 RIP

RIP

RIP

RIP

RIP

| Ruijie(config-router)# <b>passive-interface</b> {default   interface-type interface-num}           |  |
|--|--|
| Ruijie(config-router)# <b>no</b> <b>passive-interface</b> {default   interface-type interface-num} |  |



RIP

RIP

RIP

| Ruijie(config-if)# <b>no ip rip receive enable</b> | RIP |
|--|-----|
| Ruijie(config-if)# <b>ip rip receive enable</b>    | RIP |

RIP

| Ruijie(config-if)# <b>no ip rip send enable</b> | RIP |
|---|-----|
| Ruijie(config-if)# <b>ip rip send enable</b>    | RIP |

### 32.2.10 RIP

0.0.0.0/0 ,

|  |  |
|--|--|
|  |  |
| Ruijie(config-if)# <b>ip rip default-information originate</b> [metric <i>metric-value</i> ] |  |
| Ruijie(config-if)# <b>no ip rip default-information</b>                                      |  |

0.0.0.0/0 ,

RIP

|   |  |
|---|--|
|   |  |
| Ruijie(config-if)# <b>ip rip default-information only</b> [metric <i>metric-value</i> ] |  |
| Ruijie(config-if)# <b>no ip rip default-information</b>                                 |  |



**ip rip default-information** RIP  
**default-information originate**

### 32.2.11 RIP VRF

RIP VRF RIP RIP VRF VRF  
RIP VRF RIP VRF RIP VRF  
RIP VRF  
**address-family**  
(config-router-af)# VRF RIP VRF RIP  
VRF RIP RIP  
RIP  
**exit-address-family** **exit**  
VRF RIP RIP

|   |                            |
|---|----------------------------|
|   |                            |
| Ruijie(config-router)# <b>address-family ipv4 vrf</b> <i>vrf-name</i> | <i>vrf-name</i> VRF<br>RIP |



## 1 RIP

1                   RIP

2 RouterB RouterC  
192.168.12.0/24

3 RouterE

●

```

RouterA           RouterB                   RouterA RouterD
                                          RouterC RouterD           192.168.12.0
RouterE
```

A

```

#
interface GigabitEthernet0/0
ip address 192.168.12.1 255.255.255.0

#
interface Serial1/0
ip address 192.168.123.1 255.255.255.0
encapsulation frame-relay
no ip split-horizon

#     RIP
router rip
version 2
network 192.168.12.0
network 192.168.123.0
```

B

```

#
interface GigabitEthernet0/0
ip address 172.16.20.1 255.255.255.0

#
interface Serial1/0
ip address 192.168.123.2 255.255.255.0
encapsulation frame-relay

#     RIP
router rip
version 2
network 172.16.0.0
network 192.168.123.0
```

```
no auto-summary
```

### C

```
#  
interface GigabitEthernet0/0  
ip address 172.16.30.1 255.255.255.0  
  
#  
interface Serial1/0  
ip address 192.168.123.3 255.255.255.0  
encapsulation frame-relay
```

```
#    RIP  
router rip  
version 2  
network 172.16.0.0  
network 192.168.123.0  
no auto-summary
```

### D

```
#  
interface GigabitEthernet0/0  
ip address 192.168.12.4 255.255.255.0  
ip address 192.168.13.4 255.255.255.0 secondary  
no ip split-horizon
```

```
#    RIP  
router rip  
version 2  
network 192.168.12.0  
network 192.168.13.0
```

### E

```
#  
interface GigabitEthernet0/0  
ip address 192.168.13.5 255.255.255.0
```

```
#    RIP  
router rip  
version 2  
network 192.168.13.0
```

## 32.3.2 RIP

•

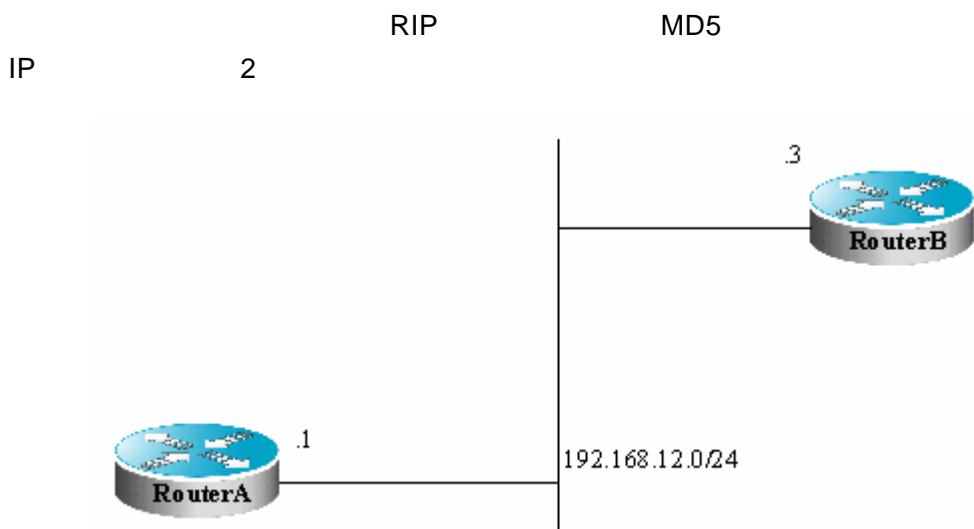

**2 RIP**

|          |     |      |      |      |     |
|----------|-----|------|------|------|-----|
| Router A | RIP | Keya | Keya | Keyb | RIP |
| Router B | RIP | Keyb | Keya | Keyb | RIP |

•

A

```
#
key chain ripkey
key 1
key-string keya
accept-lifetime 00:00:00 Dec 3 2000 infinite
send-lifetime 00:00:00 Dec 4 2000 infinite
key 2
key-string keyb
accept-lifetime 00:00:00 Dec 3 2000 infinite
send-lifetime 00:00:00 Dec 4 2000 infinite

#
interface GigabitEthernet0/0
ip address 192.168.12.1 255.255.255.0
ip rip authentication mode md5
ip rip authentication key-chain ripkey
```

```

B      :

#
key chain ripkey
key 1
key-string keyb
accept-lifetime 00:00:00 Dec 3 2000 infinite
send-lifetime 00:00:00 Dec 4 2000 00:00:00 Dec 5 2000
key 2
key-string keya
accept-lifetime 00:00:00 Dec 3 2000 infinite
send-lifetime 00:00:00 Dec 4 2000 infinite

#
interface GigabitEthernet0/0
ip address 192.168.12.2 255.255.255.0
ip rip authentication mode md5
ip rip authentication key-chain ripkey

#      RIP
router rip
version 2
network 192.168.12.0
```

### 32.3.3 RIP

- 

3

RIP

IP

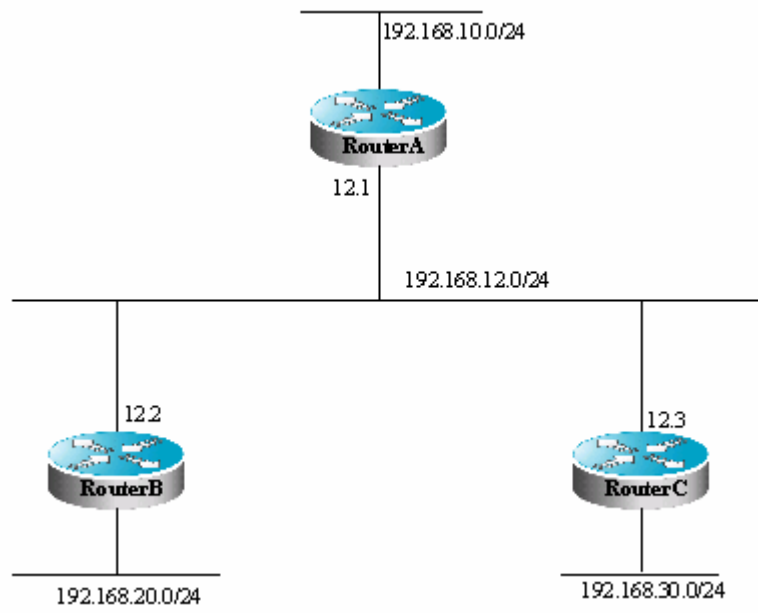

**3 RIP**

RIP

- 1 Router A                  Router C

```
#
interface GigabitEthernet0/0
ip address 192.168.12.2 255.255.255.0

#
interface Loopback0
ip address 192.168.20.1 255.255.255.0

#   RIP
router rip
version 2
network 192.168.12.0
network 192.168.20.0
```

### C

```
#
interface GigabitEthernet0/0
ip address 192.168.12.3 255.255.255.0

#
interface Loopback0
ip address 192.168.30.1 255.255.255.0

#   RIP
router rip
version 2
network 192.168.12.0
network 192.168.30.0
```

## 32.3.4 RIP VRF

- 

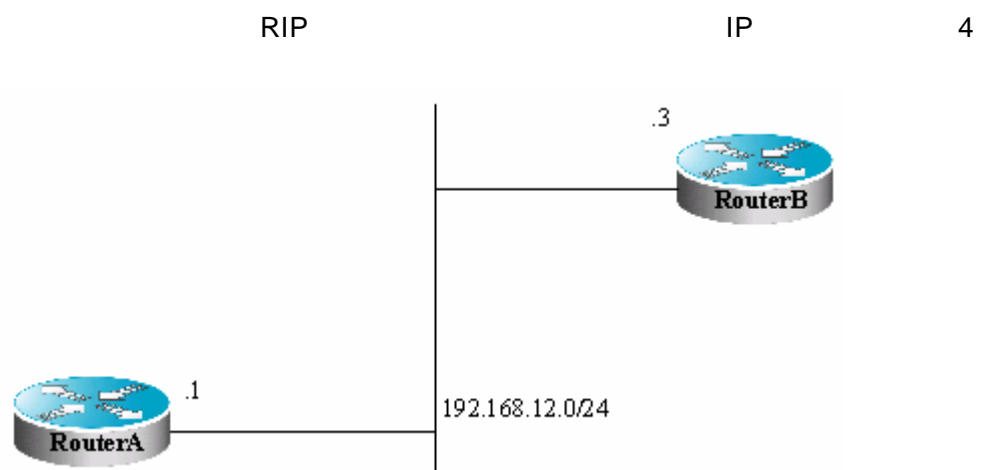

---

#### 4 RIP VRF

RIP Router A redvpn VRF Router B bluevpn VRF

●

A

```
# VRF
ip vrf redvpn

# VRF
interface GigabitEthernet 1/0
ip vrf forwarding redvpn
ip address 192.168.12.1 255.255.255.0

# RIP RIP
router rip
address-family ipv4 vrf redvpn
network 192.168.12.0
exit-address-family
```

B :

```
# VRF
ip vrf bluevpn

# VRF
interface GigabitEthernet 1/0
ip vrf forwarding bluevpn
ip address 192.168.12.3 255.255.255.0

# RIP RIP
router rip
address-family ipv4 vrf bluevpn
network 192.168.12.0
exit-address-family
```

# 33 OSPF

## 33.1 OSPF

OSPF, Open Shortest Path First  
IETF OSPF

- 1)
- 2) ABR Area Border Routers ,
- 3) ASBR Autonomous System Boundary Routers , OSPF
- OSPF RFC 2328 OSPF v2
- OSPF
- 1) OSPF 64 OSPF
- 2) VRF VRF OSPF
- 3) —
- 4) — RIP BGP
- 5) — MD5
- 6) —
- 7) VLSMs
- 8)
- 9) NSSA Not So Stubby Area RFC 3101
- 10) Graceful Restart RFC 3623



- 1) OSPF RFC 1793
  - 2) OSPF
- 

## 33.2 OSPF

OSPF

OSPF

OSPF  
OSPF

- OSPF (
- OSPF
- OSPF
- OSPF
- OSPF NSSA
- OSPF
- 
- 
- Loopback
- OSPF
- 
- 
- OSPF
- 
- MTU
- OSPF
- OSPF
- OSPF BFD
- 
- 

OSPF

|  |   |
|--|---|
|  | <pre> : LSA :5 LSA :1 hello :10 ( 30 ) : hello 1 0 ( )                 </pre> |
|  | <pre> 0( ) Stub NSSA : 1  (STUB): (NSSA):                 </pre>              |

|                            |  |
|----------------------------|--|
|                            | <pre> : LSA :5 LSA :1 hello :10 : hello </pre> |
|                            | 100 Mbps                                       |
|                            | metric 1 type-2                                |
| metric<br>(Default metric) | metric   |
|                            | <pre> 110 110 110 </pre>                       |
|                            | LSA  |

|             |  |
|-------------|--|
| OSPFv2 TRAP |  |
|-------------|--|

### 33.2.1 OSPF

```

OSPF
OSPF OSPF
IP
64 OSPF
IP
OSPF
OSPF
    
```

|   |           |
|---|-----------|
|   |           |
| Ruijie # <b>configure terminal</b>  |           |
| Ruijie (config)# <b>ip routing</b>  | ( )       |
| Ruijie (config)# <b>router ospf</b><br><i>process_id [vrf vrf-name]</i>                       | OSPF OSPF |
| Ruijie (config-router)# <b>network</b><br><i>address wildcard-mask area</i><br><i>area-id</i> |           |
| Ruijie (config-router)# <b>end</b>  |           |
| Ruijie # <b>show ip protocols</b>   |           |
| Ruijie # <b>write</b>   |           |



```

vrf vrf-name OSPF vrf OSPF
VRF OSPF VRF Network 32 " "
"1" "0"
network IP
OSPF network
IP OSPF
    
```

**no router ospf process-id** OSPF OSPF

```

Ruijie(config)# router ospf 1
Ruijie(config-router)# network 192.168.0.0 0.0.0.255 area 0
Ruijie(config-router)# end
    
```

### 33.2.2 OSPF

OSPF

ip ospf hello-interval, ip ospf dead-interval, ip ospf authentication ip ospf authentication-key ip ospf message-digest-key

OSPF

| Ruijie # <b>configure terminal</b> |     |
|------------------------------------|-----|
| Ruijie (config)# <b>ip routing</b> | ( ) |
| Ruijie (config)# <b>interface</b>  |     |

|  |                 |
|--|-----------------|
| Ruijie (config-if)# <b>ip ospf database-filter all out</b>         | OSPF LSA<br>LSA |
| Ruijie (config-if)# <b>end</b>                                     |                 |
| Ruijie # <b>show ip ospf [process-id] interface [interface-id]</b> |                 |
| Ruijie # <b>write</b>  |                 |

no

### 33.2.3 OSPF

- OSPF
  - FDDI
  - X.25
  - HDLC PPP SLIP
- OSPF
  1. (NBMA) NBMA
    - SVC X.25 PVC
    - OSPF NBMA
    - Designated Router NBMA
  2.
    - X.25 OSPF
    - X.25 map Frame-relay map X.25
    - OSPF X.25
    - OSPF NBMA
- 
-

|  |      |
|--|------|
|  |      |
| Ruijie(config-if)# <b>ip ospf network</b> {broadcast   non-broadcast   point-to-point   point-to-multipoint [non-broadcast]} | OSPF |

- 
- PPP SLIP X.25
- NBMA (non-broadcast) X.25
- 
- FULL

33.2.3.1

X.25  
OSPF  
neighbor

|   |  |
|---|--|
|   |  |
| Ruijie(config-if)# <b>ip ospf network point-to-multipoint</b> |  |
| Ruijie(config-if)# <b>exit</b>                                |  |
| Ruijie(config)# <b>router ospf 1</b>                          |  |
| Ruijie(config-router)# <b>neighbor ip-address cost cost</b>   |  |



OSPF

X.25

### 33.2.3.2

ospf

NBMA

ospf

NBMA

1.

2.

NBMA

```
Ruijie (config)# router ospf 1
```

```

                ( no-summary )
2
OSPF
1
( area
default-cost )
STUB
• STUB STUB
• STUB
• Stub ASBR
OSPF

```

|   |   |
|---|---|
|   |   |
| Ruijie (config-router)# <b>area area-id authentication</b>                |   |
| Ruijie (config-router)# <b>area area-id authentication message-digest</b> | MD5   |
| Ruijie (config-router)# <b>area area-id stub [no-summary]</b>             | <b>no-summary:</b><br>Stub ABR<br>summary-LSAs stub |
| Ruijie (config-router)# <b>area area-id default-cost cost</b>             | STUB  |



“ OSPF ”

### 33.2.5 OSPF NSSA

```

NSSA(Not-So-Stubby Area) OSPF STUB ,NSSA 5
LSA(AS-external-LSA) NSSA , STUB
NSSA OSPF

```

LSA NSSA NSSA 7 NSSA , 7  
5 LSA

NSSA





Ruijie (config-router)# **area** *area-id* **range**  
*ip-address mask* [**advertise** | **not-advertise**]

discard

### 33.2.7

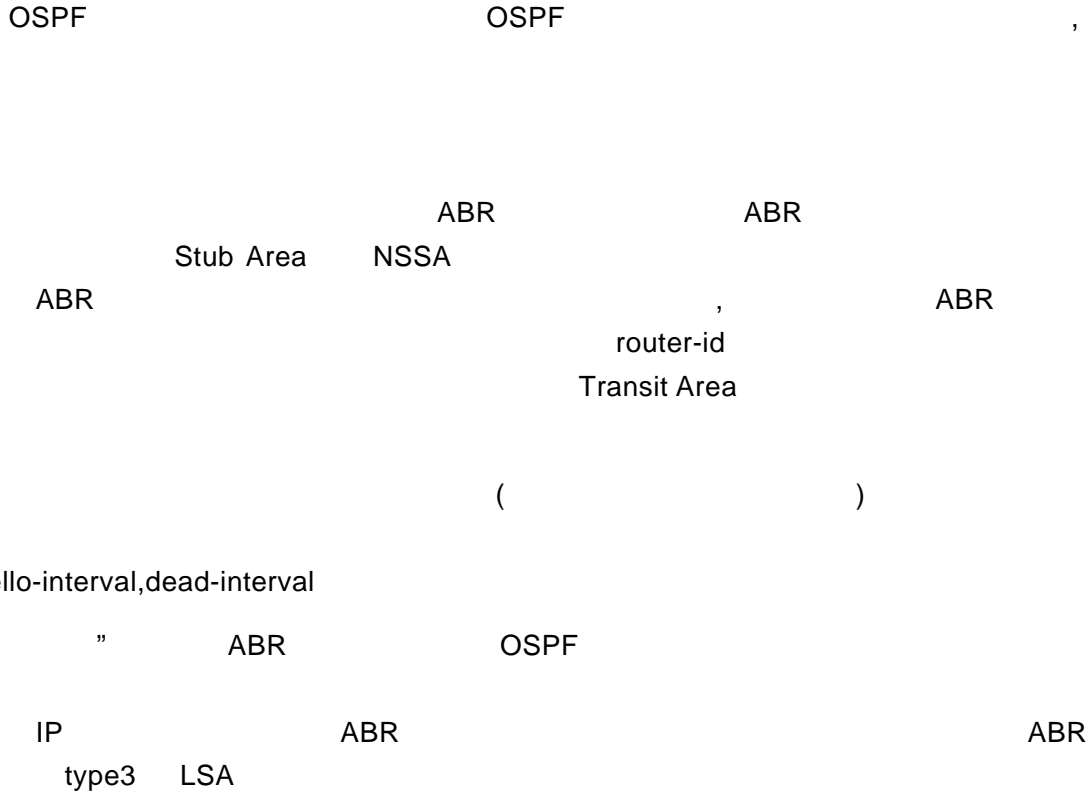

|   |  |
|---|--|
|   |  |
| <pre> Ruijie (config-router)# area area-id virtual-link router-id [[hello-interval seconds]] [retransmit-interval seconds] [[transmit-delay seconds]][dead-interval seconds]] [authentication [message-digest   null]] [[[authentication-key key   message-digest-key keyid md5 key]]]         </pre> |  |



router-id OSPF router-id **show ip ospf**  
**show ip ospf neighbor** router-id

### 33.2.8

(ASBR)

ASBR OSPF  
ASBR ASBR

ASBR

|  |  |
|--|--|
| •  |  |
| Ruijie (config-router)#<br><b>default-information originate</b> [always]<br>[metric <i>metric-value</i> ] [metric-type<br><i>type-value</i> ] [route-map <i>map-name</i> ] |  |



### 33.2.9 Loopback

OSPF IP IP  
,OSPF  
Loopback Loopback IP  
Loopback IP  
Loopback

|   |             |
|---|-------------|
|   |             |
| Ruijie (config)#<br><b>interface loopback 1</b>                 | Loopback    |
| Ruijie (config-if)#<br><b>ip address</b> <i>ip-address mask</i> | Loopback IP |



OSPF

IP

loopback

OSPF

### 33.2.10 OSPF

0~255

OSPF

110

OSPF

| Ruijie(config-router)# <b>distance</b> { <i>distance</i>   <b>ospf</b> { <b>intra-area</b> <i>distance</i>   <b>inter-area</b> <i>distance</i>   <b>external</b> <i>distance</i> }} | OSPF |
|---|------|

### 33.2.11

OSPF

SPF

LSA

40~100

10~20

|  |           |
|--|-----------|
|  |           |
| Ruijie # <b>configure terminal</b>                                 |           |
| Ruijie (config)# <b>router ospf 1</b>                              | OSPF OSPF |
| Ruijie (config-router)# <b>timers<br/>lsa-group-pacing seconds</b> |           |
| Ruijie (config-router)# <b>end</b>                                 |           |
| Ruijie # <b>show running-config</b>                                |           |
| Ruijie # <b>write</b>  |           |

**no timers lsa-group-pacing**

### 33.2.13 OSPF

OSPF

Cost

Cost

OSPF

ip ospf cost

100Mbps

10Mbps

$100/10 + 0.5 = 10$

10



|   |        |
|---|--------|
| Ruijie(config-router)# <b>auto-cost<br/>reference-bandwidth</b> <i>ref-bw</i> | ref-bw |
| Ruijie (config-router)# <b>end</b>  |        |
| Ruijie # <b>show ip protocols</b>   |        |
| Ruijie # <b>write</b>   |        |

|                      |  |
|----------------------|--|
| Ruijie# <b>write</b> |  |
|----------------------|--|

OSPF

**no passive-interface** *interface-id* default

### 33.2.16 OSPF

#### 33.2.16.1 OSPFv2 MIB

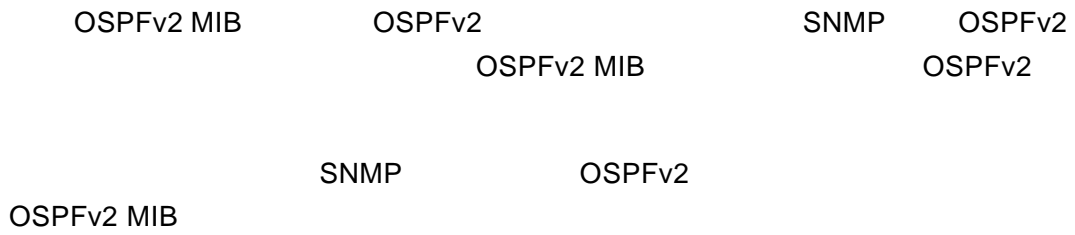

|   |                      |
|---|----------------------|
| •   |                      |
| Ruijie (config-router)# <b>enable mib-binding</b> | OSPFv2 MIB<br>OSPFv2 |

#### 33.2.16.2 OSPFv2 TRAP

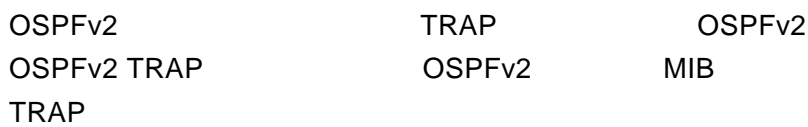

|                                    |  |
|------------------------------------|--|
|                                    |  |
| Ruijie # <b>configure terminal</b> |  |

|  |  |
|--|--|
| Ruijie (config)# <b>snmp-server host</b><br><i>host-ip version version-no string</i><br><b>[ospf]</b>  | TRAP<br>snmp-server host-ip server<br>version-no server<br>snmp string<br>snmp<br>public ospf<br>snmp-server OSPF TRAP<br>server<br>TRAP |
| Ruijie (config)# <b>snmp-server enable</b><br><b>traps ospf</b>  | OSPF TRAP  |
| Ruijie (config)# <b>router ospf</b><br><i>process_id [vrf vrf-name]</i>  | OSPF OSPF  |
| Ruijie (config-router)# <b>enable traps</b><br><b>[error</b><br><b>[ifauthfailure   ifconfigerror  </b><br><b>ifrxbadpacket   virtifauthfailure  </b><br><b>virtifconfigerror  </b><br><b>virtifrxbadpacket]  </b><br><b>lsa [lsdbapproachoverflow  </b><br><b>lsdboverflow   maxagelsa  </b><br><b>originatelsa]   retransmit</b><br><b>[iftxretransmit   virtiftxretransmit]  </b><br><b>state-change [ifstatechange  </b><br><b>nbrstatechange  </b><br><b>virtifstatechange  </b><br><b>virtnbrstatechange]]</b> | OSPF TRAP  |
| Ruijie (config)# <b>end</b>  |  |
| Ruijie# <b>write</b>   |  |

### 33.3

### OSPF

OSPF

|  |   |
|--|---|
|  |   |
| Ruijie# <b>show ip ospf</b> [ <i>process-id</i> ]  | OSPF  |
| Ruijie# <b>show ip ospf</b> [ <i>process-id area-id</i> ]<br><b>database</b> [ <i>adv-router ip-address</i>  <br>{ <i>asbr-summary</i>   <i>external</i>   <i>network</i>  <br><i>nssa-external</i>   <i>opaque-area</i>   <i>opaque-as</i>  <br><i>opaque-link</i>   <i>router</i>   <i>summary</i> }<br>[ <i>link-state-id</i> ] [{ <i>adv-router ip-address</i>  <br><i>self-originate</i> }]   <b>database-summary</b>  <br><b>max-age</b>   <b>self-originate</b> ] | OSPF<br><br>LSA   |
| Ruijie# <b>show ip ospf</b> [ <i>process-id</i> ]<br><b>border-routers</b>   | ASBR<br>ABR   |
| Ruijie# <b>show ip ospf interface</b><br>[ <i>interface-name</i> ]   | ospf  |
| Ruijie# <b>show ip ospf</b> [ <i>process-id</i> ]<br><b>neighbor</b> [ <i>interface-name</i> ] [ <i>neighbor-id</i> ]<br>[ <b>detail</b> ]   | interface-name<br>neighbor<br><br>neighbor-id: neighbor<br>ID |
| Ruijie# <b>show ip ospf</b> [ <i>process-id</i> ]<br><b>virtual-links</b> <i>ip-address</i>  |   |
| Ruijie# <b>show ip ospf</b> [ <i>process-id</i> ] <b>route</b><br>[ <b>count</b> ]   | OSPF  |

OSPF

1 OSPF

**show ip ospf** [*process-id*] **neighbor** OSPF  
IP

```
Ruijie # show ip ospf neighbor
OSPF process 1:
Neighbor ID Pri State      Dead Time      Address Interface
10.10.10.50 1 Full/DR 00:00:38      10.10.10.50 eth0/0
OSPF process 100:
Neighbor ID Pri State      Dead Time      Address Interface
10.10.11.50 1 Full/Backup 00:00:31 10.10.11.50 eth0/1
```

Ruijie # **show ip ospf 1 neighbor**

OSPF process 1:

| Neighbor ID | Pri | State   | Dead Time | Address     | Interface |
|-------------|-----|---------|-----------|-------------|-----------|
| 10.10.10.50 | 1   | Full/DR | 00:00:38  | 10.10.10.50 | eth0      |

Ruijie # **show ip ospf 100 neighbor**

OSPF process 100:

| Neighbor ID | Pri | State       | Dead Time | Address     | Interface |
|-------------|-----|-------------|-----------|-------------|-----------|
| 10.10.11.50 | 1   | Full/Backup | 00:00:31  | 10.10.11.50 | eth1      |

## 2 OSPF

| F0/1         | OSPF | 0            | 172.16.120.1 |
|--------------|------|--------------|--------------|
| "BROADCAST"— | Area | Netwrok Type | Hello Dead   |

Ruijie#**sh ip ospf interface GigabitEthernet 1/0**

GigabitEthernet 1/0 is up, line protocol is up

Internet Address 192.168.1.1/24, Ifindex: 2 Area 0.0.0.0, MTU 1500

Matching network config: 192.168.1.0/24

Process ID 1, Router ID 192.168.1.1, Network Type BROADCAST, Cost: 1

Transmit Delay is 1 sec, State DR, Priority 1

Designated Router (ID) 192.168.1.1, Interface Address 192.168.1.1

Backup Designated Router (ID) 192.168.1.2, Interface Address 192.168.1.2

Timer intervals configured, Hello 10, Dead 40, Wait 40, Retransmit 5

Hello due in 00:00:04

Neighbor Count is 1, Adjacent neighbor count is 1

Crypt Sequence Number is 30

Hello received 972 sent 990, DD received 3 sent 4

LS-Req received 1 sent 1, LS-Upd received 10 sent 26

LS-Ack received 25 sent 7, Discarded 0

## 3 OSPF

Ruijie# **show ip ospf**

Routing Process "ospf 1" with ID 1.1.1.1

Process uptime is 4 minutes

Process bound to VRF default

Conforms to RFC2328, and RFC1583Compatibility flag is enabled

Supports only single TOS(TOS0) routes

Supports opaque LSA

This router is an ASBR (injecting external routing information)  
SPF schedule delay 5 secs, Hold time between two SPFs 10 secs  
LsaGroupPacing: 240 secs  
Number of incoming current DD exchange neighbors 0/5  
Number of outgoing current DD exchange neighbors 0/5  
Number of external LSA 4. Checksum 0x0278E0  
Number of opaque AS LSA 0. Checksum 0x000000  
Number of non-default external LSA 4  
External LSA database is unlimited.  
Number of LSA originated 6  
Number of LSA received 2  
Log Neighbor Adjacency Changes : Enabled  
Number of areas attached to this router: 1  
Area 0 (BACKBONE)  
Number of interfaces in this area is 1(1)  
Number of fully adjacent neighbors in this area is 1  
Area has no authentication  
SPF algorithm last executed 00:01:26.640 ago  
SPF algorithm executed 4 times  
Number of LSA 3. Checksum 0x0204bf

Routing Process "ospf 20" with ID 2.2.2.2  
Process uptime is 4 minutes  
Process bound to VRF default  
Conforms to RFC2328, and RFC1583Compatibility flag is enabled  
Supports only single TOS(TOS0) routes  
Supports opaque LSA  
SPF schedule delay 5 secs, Hold time between two SPFs 10 secs  
LsaGroupPacing: 240 secs  
Number of incoming current DD exchange neighbors 0/5  
Number of outgoing current DD exchange neighbors 0/5  
Number of external LSA 0. Checksum 0x000000  
Number of opaque AS LSA 0. Checksum 0x000000  
Number of non-default external LSA 0

8 OSPF

- OSPF NBMA
- OSPF
- OSPF
- OSPF
- OSPF ABR ASBR
- OSPF
- OSPF

33.4.1 OSPF NBMA

- 

PVC

IP

1

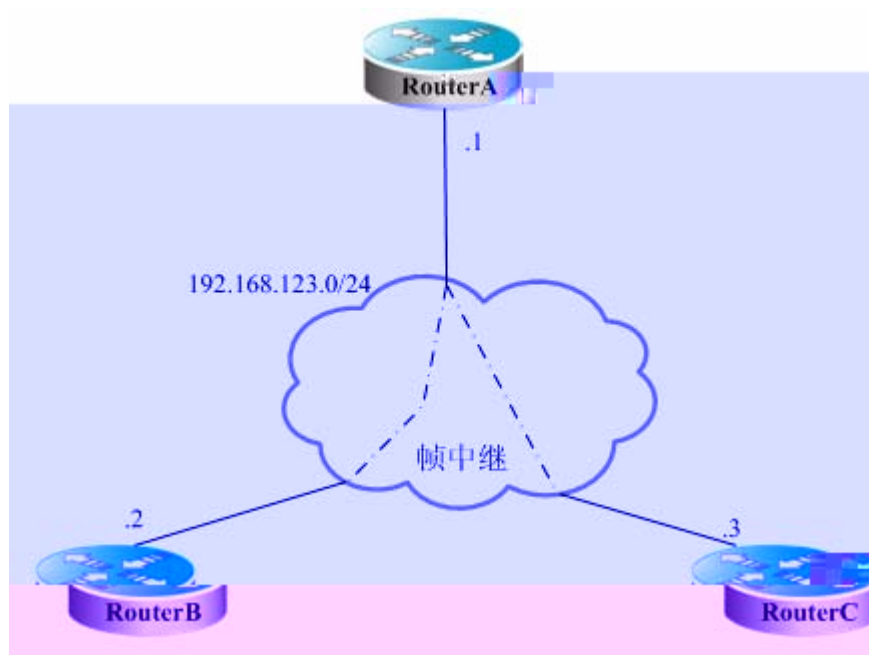

3. OSPF NBMA

|   |       |      |
|---|-------|------|
| 1 | A B C | NBMA |
| 2 | A     | B    |
| 3 |       |      |

4



OSPF

OSPF

IP

NBMA

SPF

A

```
interface Serial 1/0
ip address 192.168.123.1 255.255.255.0
encapsulation frame-relay
ip ospf network non-broadcast
ip ospf priority 10
```

OSPF

B

```
router ospf 1
network 192.168.123.0 0.0.0.255 area 0
neighbor 192.168.123.2 priority 5
neighbor 192.168.123.3
timers spf 500 1000 10000
```

B

```
interface Serial 1/0
ip address 192.168.123.2 255.255.255.0
encapsulation frame-relay
ip ospf network non-broadcast
ip ospf priority 5
```

OSPF

```
router ospf 1
network 192.168.123.0 0.0.0.255 area 0
neighbor 192.168.123.1 priority 10
neighbor 192.168.123.3
timers spf 500 1000 10000
```

C

```
interface Serial 1/0
ip address 192.168.123.3 255.255.255.0
```

```
encapsulation frame-relay  
ip ospf network non-broadcast
```

### OSPF

```
router ospf 1  
network 192.168.123.0 0.0.0.255 area 0  
neighbor 192.168.123.1 10  
neighbor 192.168.123.2 5  
timers spf 500 1000 10000
```

## 33.4.2 OSPF

-

**A**

```
interface GigabitEthernet 0/0
ip address 192.168.12.1 255.255.255.0
```

```
interface Serial 1/0
ip address 192.168.123.1 255.255.255.0
encapsulation frame-relay
ip ospf network point-to-multipoint
```

**OSPF**

```
router ospf 1
network 192.168.23.0 0.0.0.255 area 0
network 192.168.123.0 0.0.0.255 area 0
```

**B**

```
interface GigabitEthernet 0/0
ip address 192.168.23.2 255.255.255.0
```

```
interface Serial 1/0
ip address 192.168.123.2 255.255.255.0
encapsulation frame-relay
ip ospf network point-to-multipoint
```

**OSPF**

```
router ospf 1
network 192.168.23.0 0.0.0.255 area 0
network 192.168.123.0 0.0.0.255 area 0
```

**C**

```
interface GigabitEthernet 0/0
ip address 192.168.23.3 255.255.255.0
```

```
interface Serial 1/0
ip address 192.168.123.3 255.255.255.0
```



A

```
interface GigabitEthernet0/0
ip address 192.168.12.1 255.255.255.0
ip ospf message-digest-key 1 md5 hello
```

OSPF

```
router ospf 1
network 192.168.12.0 0.0.0.255 area 0
area 0 authentication message-digest
```

B

```
interface GigabitEthernet0/0
ip address 192.168.12.2 255.255.255.0
ip ospf message-digest-key 1 md5 hello
```

OSPF

```
router ospf 1
network 192.168.12.0 0.0.0.255 area 0
area 0 authentication message-digest
```

### 33.4.4 OSPF

- 

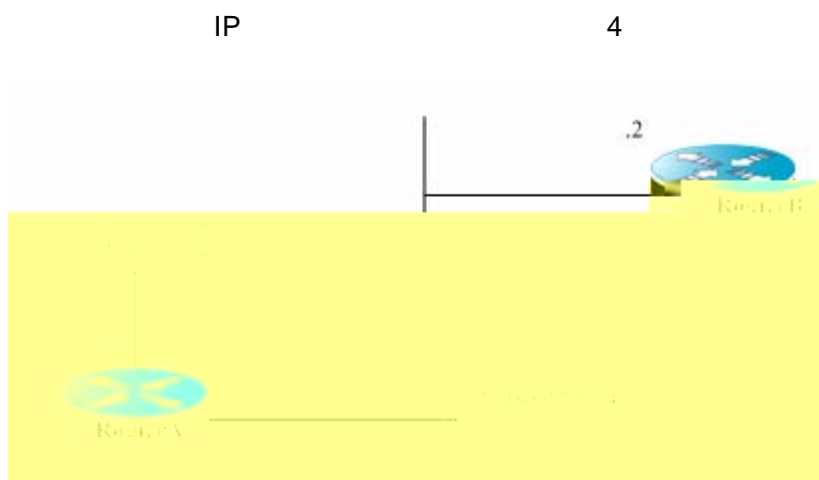

6. OSPF

1 OSPF 192.168.12.0/24 0 172.16.1.0/24  
172.16.2.0/24 10

2 Router A A 172.16.0.0/22 172.16.1.0/24  
172.16.2.0/24

3 Router A A 20  
discard



Router A OSPF

2

OSPF

A

OSPF 172.16.0.0/22 172.16.1.0/24 172.16.2.0/24

```
network 192.168.12.0 0.0.0.255 area 0
```

### 33.4.5 OSPF ABR ASBR

- 

```

0 OSPF 192.168.12.0/24 192.168.23.0/24
  192.168.34.0/24 34 IP 5
  
```

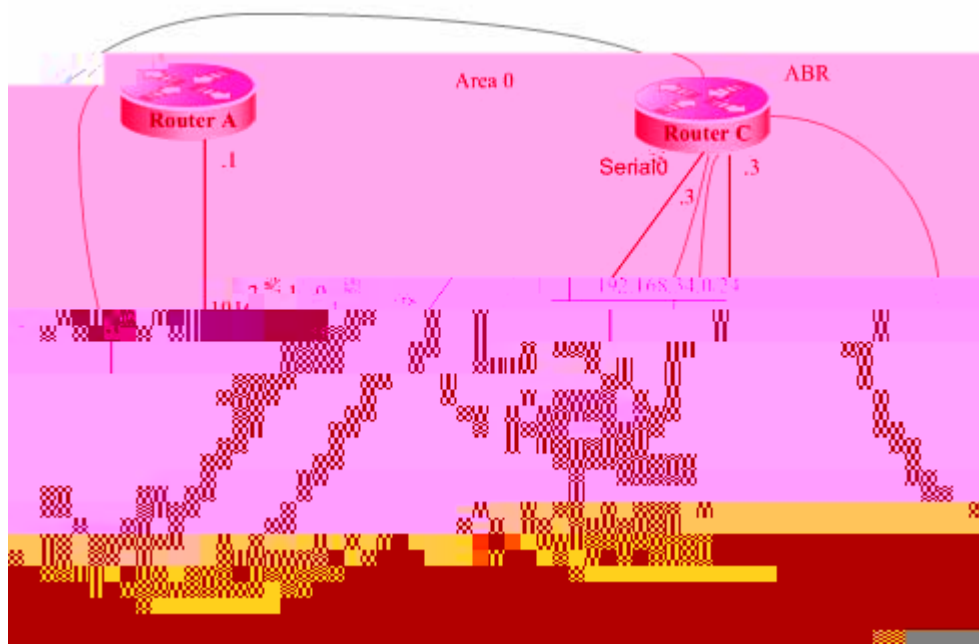

#### 7. OSPF ABR ASBR

```

A B C D
200.200.1.0/24
  
```

**B**

```
interface GigabitEthernet0/0
ip address 192.168.12.2 255.255.255.0
```

```
interface Serial 1/0
ip address 192.168.23.2 255.255.255.0
```

**OSPF**

```
router ospf 1
network 192.168.12.0 0.0.0.255 area 0
network 192.168.23.0 0.0.0.255 area 0
```

**C**

```
interface GigabitEthernet 0/0
ip address 192.168.34.3 255.255.255.0
```

```
interface Serial 1/0
ip address 192.168.23.3 255.255.255.0
```

#

```
router area 0
network 192.168.23.0 0.0.0.255 area 0
ospf 1
network 192.168.23.0 0.0.0.255 area 0
```

**A' Ü C**

```
interface GigabitEthernet 0/0
ip address 192.168.23.2 255.255.255.0
```

```
interface Gi(nte[r](r)6(oute)6eri)6(al 1/)6(0)6( )TJ0 Tw T*7210
```

```
OSPF 5%0ÄV%V%V, $ô
```

```

router ospf 1
network 192.168.34.0 0.0.0.255 area 34
redistribute rip metric-type 1 subnets tag 34
    
```

**RIP**

```

router rip
network 200.200.1.0
network 172.200.0.0
    
```

**B          ospf    " E1"**

```

O E1 200.200.1.0/24 [110/85] via 192.168.23.3, 00:00:33, Serial1/0
O IA 192.168.34.0/24 [110/65] via 192.168.23.3, 00:00:33, Serial1/0
O E1 172.200.1.0 [110/85] via 192.168.23.3, 00:00:33, Serial1/0
    
```

**33.4.6 OSPF**

- 

192.168.12.0/24 192.168.23.0/24

6

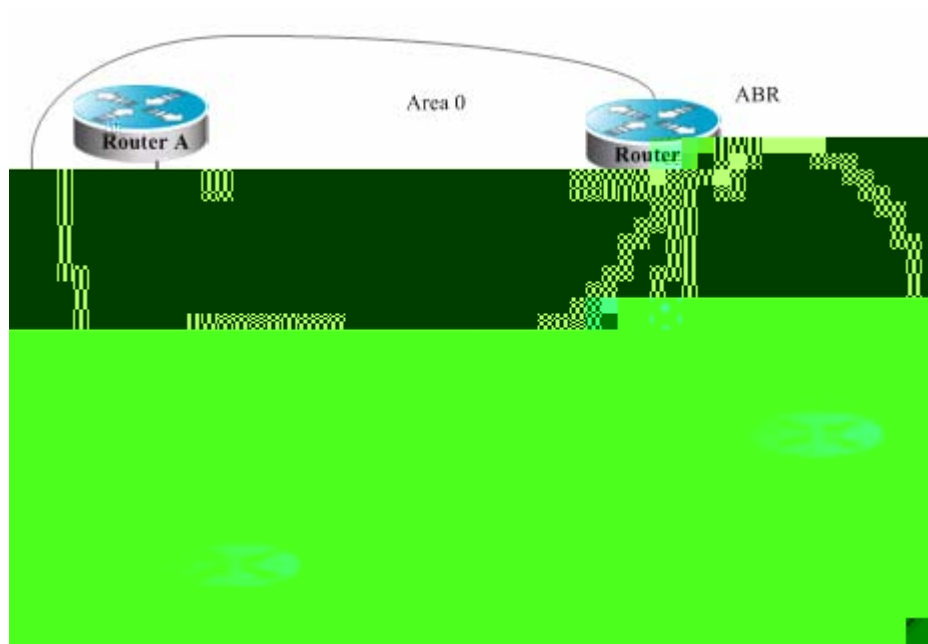

**8 OSPF**

RouterD

OSPF

192.168.30.0/24

D

C

```
router ospf 1
network 192.168.23.0 0.0.0.255 area 0
network 192.168.34.0 0.0.0.255 area 34
network 192.168.30.0 0.0.0.255 area 34
area 34 stub no-summary
```

D

```
interface GigabitEthernet0/0
ip address 192.168.34.4 255.255.255.0
```

### OSPF

```
router ospf 1
network 192.168.34.0 0.0.0.255 area 34
area 34 stub
```

D            ospf

```
O 192.168.30.0/24 [110/1786] via 192.168.34.3, 00:00:03,
GigabitEthernet0/0
O*IA 0.0.0.0/0 [110/2] via 192.168.34.3, 00:00:03,
GigabitEthernet0/0
```

## 33.4.7 OSPF

●

|                 |      |                 |       |
|-----------------|------|-----------------|-------|
|                 | OSPF | 192.168.12.0/24 | 0     |
| 192.168.23.0/24 | 23   | 192.168.34.0/24 | 34 IP |
| 7               |      |                 |       |



## 9. OSPF

D            192.168.12.0/24   192.168.23.0/24

●

OSPF

area 0

ABR

A

```
interface GigabitEthernet0/0  
ip address 192.168.12.1 255.255.255.0
```

OSPF

```
router ospf 1  
network 192.168.12.0 0.0.0.255 area 0
```

B

```
interface GigabitEthernet0/0  
ip address 192.168.12.2 255.255.255.0
```

```
interface Serial1/0  
ip address 192.168.23.2 255.255.255.0
```

**IP            OSPF**

```
interface Loopback2
ip address 2.2.2.2 255.255.255.0
```

**OSPF**

```
router ospf 1
network 192.168.12.0 0.0.0.255 area 0
network 192.168.23.0 0.0.0.255 area 23
area 23 virtual-link 3.3.3.3
```

**C**

```
interface GigabitEthernet0/0
ip address 192.168.34.3 255.255.255.0
```

```
interface Serial1/0
ip address 192.168.23.3 255.255.255.0
```

**IP            OSPF**

```
interface Loopback2
ip address 3.3.3.3 255.255.255.0
```

**OSPF**

```
router ospf 1
network 192.168.23.0 0.0.0.255 area 23
network 192.168.34.0 0.0.0.255 area 34
area 23 virtual-link 2.2.2.2
```

**D**

```
interface GigabitEthernet0/0
ip address 192.168.34.4 255.255.255.0
```

**OSPF**

```
router ospf 1
network 192.168.34.0 0.0.0.255 area 34
```

**D            ospf**

```
O IA 192.168.12.0/24 [110/66] via 192.168.34.3, 00:00:10,
GigabitEthernet0/0
```

O IA 192.168.23.0/24 [110/65] via 192.168.34.3, 00:00:25,  
GigabitEthernet0/0

---

# 34

## 34.1 IP

### 34.1.1



```
Ruijie(config)# ip route [vrf vrf_name] network  
mask {ip-address [157.89 1E1366 1 Tf [14 Tc 3.303 0 Td [(ip-ad0.297(s)1(s)]TJ /TT0 1 Tf 0.02
```

|  |     |
|--|-----|
|  | 255 |
|--|-----|



RIP OSPF

" down"

VRF VRF VRF VRF

1 **show ip route weight**  
 weight WCMP WCMP 32

WCMP 8

```
Ruijie(config)#ip route 10.0.0.0 255.0.0.0 172.0.1.2 weight 6
Ruijie(config)#ip route 10.0.0.0 255.0.0.0 172.0.1.4 weight 6
Ruijie(config)#show ip route 10.0.0.0
```

```
Routing entry for 10.0.0.0/8
  Distance 1, metric 0
  Routing Descriptor Blocks:
    *172.0.1.2, generated by "static"
Ruijie(config)#show ip route weight
```

```
-----[distance/metric/weight]-----
S 10.0.0.0/8 [1/0/6] via 172.0.1.2
```

1000

IP **show ip route** IP RPI

### 34.1.2

---

```

1
" 2
RIP
RIP RIP
" 0.0.0.0" OSPF
" OSPF
"

```

|  |  |
|--|--|
|  |  |
| Ruijie(config)# <b>ip default-network</b> network    |  |
| Ruijie(config)# <b>no ip default-network</b> network |  |





|   |                            |
|---|----------------------------|
| Ruijie(config-route-map)# <b>match ipv6 address</b> { <i>access-list-name</i>   <b>prefix-list</b> <i>prefix-list-name</i> }              | IPv6                       |
| Ruijie(config-route-map)# <b>match ipv6 next-hop</b> { <i>access-list-name</i>   <b>prefix-list</b> <i>prefix-list-name</i> }             |                            |
| Ruijie(config-route-map)# <b>match ipv6 route-source</b> { <i>access-list-name</i>   <b>prefix-list</b> <i>prefix-list-name</i> }         |                            |
| Ruijie(config-route-map)# <b>match metric</b> <i>Metric</i>   | <i>Metric</i> 0-4294967295 |
| Ruijie(config-route-map)# <b>match origin</b> { <b>egp</b>   <b>igp</b>   <b>incomplete</b> }   |                            |
| Ruijie(config-route-map)# <b>match route-type</b> { <b>local</b>   <b>internal</b>   <b>external</b> [ <b>level-1</b>   <b>level-2</b> ]} |                            |
| Ruijie(config-route-map)# <b>match tag</b> <i>tag</i>   | <i>tag</i> 0-4294967295    |

|  |                             |
|--|-----------------------------|
|  |                             |
| Ruijie(config-route-map)# <b>set aggregator as</b> <i>as-num ip_addr</i>   | AS                          |
| Ruijie(config-route-map)# <b>set as-path prepend</b> <i>as-number</i>  | AS_PATH                     |
| Ruijie(config-route-map)# <b>set comm-list</b> <i>community-list-number</i>   <i>community-list-name</i> <b>delete</b>                   | COMMUNITY_LIST<br>community |
| Ruijie(config-route-map)# <b>set community</b> { <i>community-number</i> [ <i>community-number</i> ...]} <b>additive</b>   <b>none</b> } | COMMUNITY                   |
| Ruijie(config-route-map)# <b>set dampening</b> <i>half-life reuse suppress max-suppress-time</i>   |                             |

|  |                    |
|--|--------------------|
| Ruijie(config-route-map)# <b>set<br/>extcommunity</b><br>{ <b>rt extend-community-value</b>   <b>soo<br/>extend-community-value</b> }        |                    |
| Ruijie(config-route-map)# <b>set interface</b><br><i>interface-type interface-number</i>   |                    |
| Ruijie(config-route-map)# <b>set ip default<br/>next-hop ip-address</b>  | IP                 |
| Ruijie(config-route-map)# <b>set ip next-hop</b><br><i>ip-address</i>  | IP                 |
| Ruijie(config-route-map)# <b>set ip next-hop<br/>verify-availability ip-address track</b><br><i>track-object-num</i>                         | IP                 |
| Ruijie(config-route-map)# <b>set level</b><br>{ <b>stub-area</b>   <b>backbone</b>   <b>level-1</b>   <b>level-1-2</b>  <br><b>level-2</b> } |                    |
| Ruijie(config-route-map)# <b>set<br/>local-preference number</b>   | LOCAL_PREFERENCE   |
| Ruijie(config-route-map)# <b>set metric</b> <i>metric</i>  |                    |
| Ruijie(config-route-map)# <b>set metric</b> [+<br><i>metric-value</i>   - <i>metric-value</i>   <i>metric-value</i> ]                        |                    |
| Ruijie(config-route-map)# <b>set metric-type</b><br>{ <b>type-1</b>   <b>type-2</b>   <b>external</b>   <b>internal</b> }                    |                    |
| Ruijie(config-route-map)# <b>set next-hop</b><br><i>next-hop</i>   | <i>next-hop</i> IP |
| Ruijie(config-route-map)# <b>set origin</b> { <b>egp</b>  <br><b>igp</b>   <b>incomplete</b> }   |                    |
| Ruijie(config-route-map)# <b>set originator-id</b><br><i>ip-addr</i>   |                    |
| Ruijie(config-route-map)# <b>set tag</b> <i>tag</i>  |                    |
| Ruijie(config-route-map)# <b>set weight</b><br><i>number</i>   | BGP                |

**match**                    **match**                    **set**  
**match**                    **set**

- 
- route-map route-map match set
  - route-map match set route-map  
route-map match set

" "



(PBR)

---

OSPF  
Type-2

OSPF

20

### **34.3.2**



```
Ruijie(config-router)# distribute-list  
{{access-list-number | access-list-name} prefix  
prefix prefix-list-name} out  
[interface-type interface-number]
```

---

## 34.4

### 34.4.1

```

                                OSPF                RIP                4    RIP
                                OSPF                type-1            40
                                OSPF
                                40

#    OSPF
Ruijie(config)# router ospf 1
Ruijie(config-router)# redistribute rip subnets route-map redrip
Ruijie(config-router)# network 192.168.12.0 0.0.0.255 area 0

#
Ruijie(config)# access-list 20 permit 200.168.23.0

#
Ruijie(config)# route-map redrip permit 10
Ruijie(config-route-map)# match metric 4
Ruijie(config-route-map)# set metric 40
Ruijie(config-route-map)# set metric-type type-1
Ruijie(config-route-map)# set tag 40

                                RIP                OSPF                10   OSPF
                                10

#    RIP
Ruijie(config)# router rip
Ruijie(config-router)# version 2
Ruijie(config-router)# redistribute ospf 1 route-map redospf
Ruijie(config-router)# network 200.168.23.0

#
Ruijie(config)# route-map redospf permit 10
Ruijie(config-route-map)# match tag 10
Ruijie(config-route-map)# set metric 10
```

---

OSPF

RIP

#

Ruijie(config)# **route-map** *redrip* **permit** 10

Ruijie(config-route-map)# **match length** 1 3

Ruijie(config-route-map)# **match route-type** **external**

Ruijie(config-route-map)# **set level** **backbone**

#

```

Ruijie(config)# ip access-list extended EXT_ACL
Ruijie(config-ext-nacl)#10 permit ip 192.168.1.0 0.0.0.255
any
Ruijie(config-ext-nacl)#10 permit ip 172.16.1.0 0.0.0.255 any

```

### 34.4.3

- 

|                 |                  |     |                |   |                 |
|-----------------|------------------|-----|----------------|---|-----------------|
|                 | 1                | A   | OSPF           | C | RIP             |
|                 | D                | BGP | B              |   | A               |
| 192.168.10.0/24 | 192.168.100.1/32 |     |                | C | 192.168.3.0/24  |
| 192.168.30.0/24 |                  | D   | 192.168.4.0/24 |   | 192.168.40.0/24 |

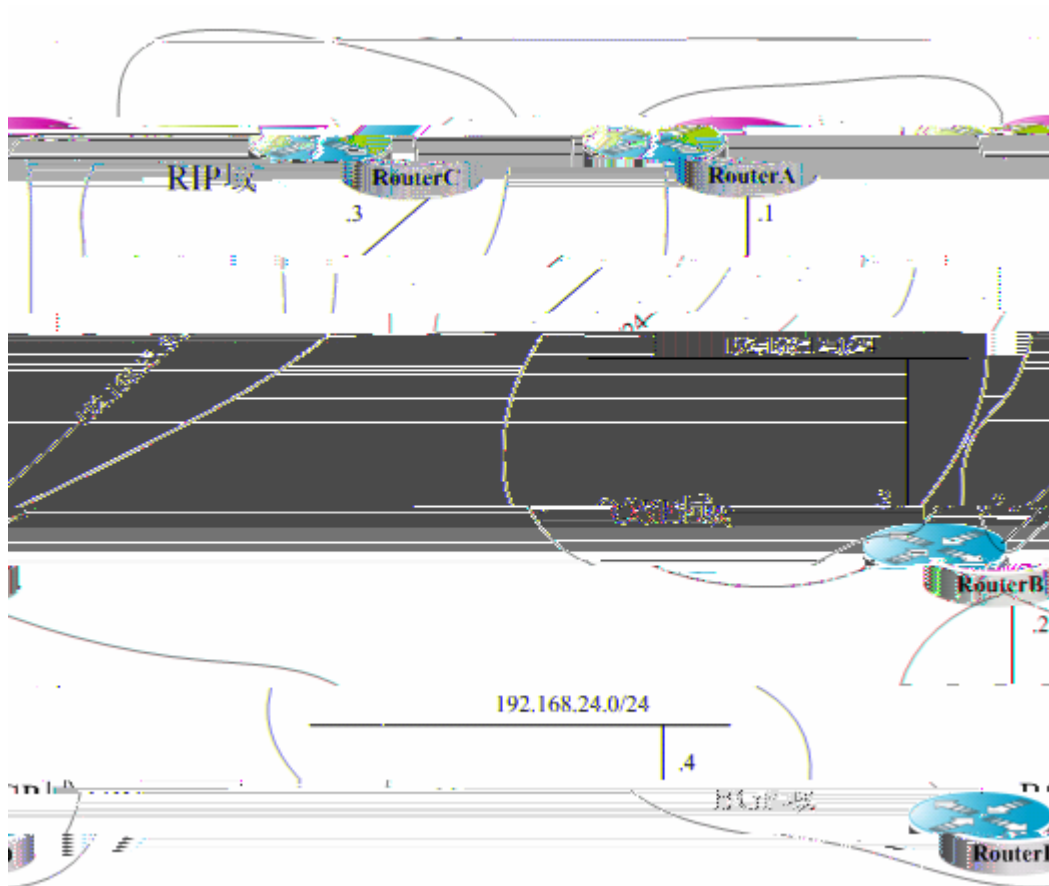

|                 |      |       |     |        |      |
|-----------------|------|-------|-----|--------|------|
|                 |      | 1     |     |        |      |
| Router B        | OSPF | RIP   |     | Type-1 |      |
| BGP             |      | 11:11 | BGP | RIP    | OSPF |
| 192.168.10.0/24 |      |       | 3   |        | RIP  |

-

---

## BGP

### A

```
#
Ruijie(config)# interface gigabitEthernet 0/0
Ruijie(config-if)# ip address 192.168.10.1 255.255.255.0
Ruijie(config)# interface loopback 1
Ruijie(config-if)# ip address 192.168.100.1 255.255.255.0
Ruijie(config-if)# no ip directed-broadcast
Ruijie(config)# interface gigabitEthernet 0/1
Ruijie(config-if)# ip address 192.168.12.55 255.255.255.0

# OSPF
Ruijie(config)# router ospf 12
Ruijie(config-router)# network 192.168.10.0 0.0.0.255 area 0
Ruijie(config-router)# network 192.168.12.0 0.0.0.255 area 0
Ruijie(config-router)# network 192.168.100.0 0.0.0.255 area 0
```

### B

```
#
Ruijie(config)# interface gigabitEthernet 0/0
Ruijie(config-if)# ip address 192.168.12.5 255.255.255.0
Ruijie(config)# interface Serial 1/0
Ruijie(config-if)# ip address 192.168.23.2 255.255.255.0

# OSPF
Ruijie(config)# router ospf 12
Ruijie(config-router)# redistribute rip metric 100 metric-type 1
subnets
Ruijie(config-router)# redistribute bgp route-map ospfrm
subnets
Ruijie(config-router)# network 192.168.12.0 0.0.0.255 area 0

# RIP
Ruijie(config)# router rip
Ruijie(config-router)# redistribute ospf 12 metric 2
Ruijie(config-router)# network 192.168.23.0
Ruijie(config-router)# distribute-list 10 out ospf
Ruijie(config-router)# default-information originate always
Ruijie(config-router)# no auto-summary
```

---

```
#      BGP
Ruijie(config)# router bgp 2
Ruijie(config-router)# neighbor 192.168.24.4 remote-as 4
Ruijie(config-router)# address-family ipv4
Ruijie(config-router-af)# neighbor 192.168.24.4 activate
Ruijie(config-router-af)# neighbor 192.168.24.4
  send-community

#
Ruijie(config)# route-map ospfrm
Ruijie(config-route-map)# match community cl_110

#
Ruijie(config)# access-list 10 permit 192.168.10.0

#      community
Ruijie(config)# ip community-list standard cl_110 permit 11:11
```

## C

```
#
Ruijie(config)# interface gigabitEthernet 0/0
Ruijie(config-if)# ip address 192.168.30.1 255.255.255.0
Ruijie(config)# interface gigabitEthernet 0/1
Ruijie(config-if)# ip address 192.168.3.1 255.255.255.0
Ruijie(config)# interface Serial 1/0
Ruijie(config-if)# ip address 192.168.23.3 255.255.255.0

#      RIP
Ruijie(config)# router rip
Ruijie(config-router)# network 192.168.23.0
Ruijie(config-router)# network 192.168.3.0
Ruijie(config-router)# network 192.168.30.0
```

## D

```
#
Ruijie(config)# interface gigabitEthernet 0/0
Ruijie(config-if)# ip address 192.168.40.1 255.255.255.0
Ruijie(config)# interface gigabitEthernet 0/1
Ruijie(config-if)# ip address 192.168.4.1 255.255.255.0
Ruijie(config)# interface gigabitEthernet 1/0
Ruijie(config-if)# ip address 192.168.24.4 255.255.255.0

#      BGP
Ruijie(config)# router bgp 4
Ruijie(config-router)# neighbor 192.168.24.2 remote-as 2
```

---

```
Ruijie(config-router)# redistribute connected route-map bgprm
Ruijie(config-router)# address-family ipv4
Ruijie(config-router-af)# neighbor 192.168.24.2 activate
Ruijie(config-router-af)# neighbor 192.168.24.2
send-community
```

```
#
```

```
Ruijie(config)# route-map bgprm
Ruijie(config-route-map)# set community 22:22
```

```
      A      OSPF      :
```

```
O E1 192.168.30.0/24 [110/101] via 192.168.12.5, 00:04:07,
GigabitEthernet0/1
O E1 192.168.3.0/24 [110/101] via 192.168.12.5, 00:04:07,
GigabitEthernet0/1
```

```
      C      RIP
```

```
R 0.0.0.0/0 [120/1] via 200.168.23.2, 00:00:00, Serial1/0
R 192.168.10.0/24 [120/2] via 200.168.23.2, 00:00:00,
Serial1/0
```



# 35

## 35.1

RGDG

- IP
- IP
- MAC
- MAC
- Expert
- IPV6

### 35.1.1

ACLs

(Access Control Lists)

Access Lists

ACLs

ACLs

QoS ACLs

ACLs

(Conditions)

(Permit)ACLs

Qs 1\*+s'E

- 

- 

WWW

TELNET

1  
1

A

B

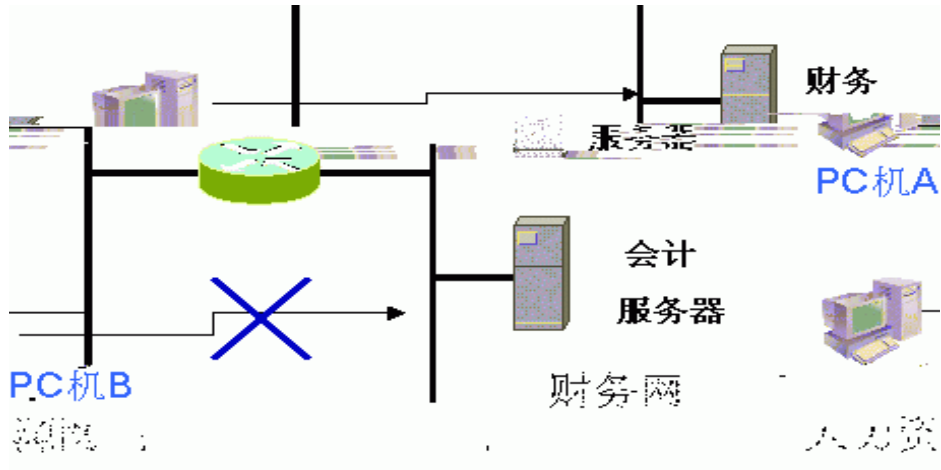

1

### 35.1.3



IPSEC

- 

INTERNET

-



### 35.1.4 / ACLt

ACL

ACL

ACL

ACE

L9e7,X~~5~~

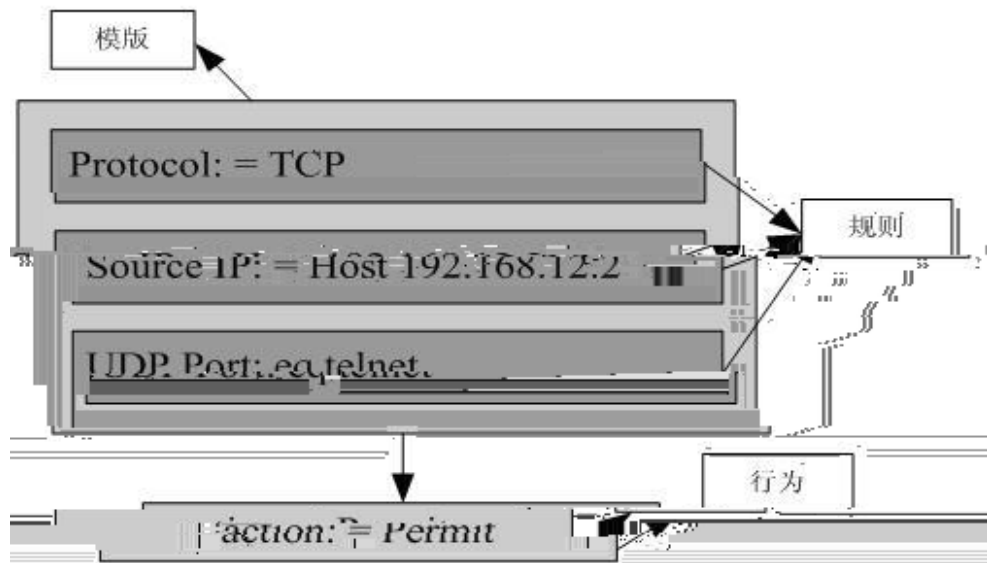

2 ACE permit tcp host 192.168.12.2 any eq telnet



Expert (Layer 2 Field) (Layer 3 Field) (Layer 4 Field) ACL Expert ACLs

## 35.2 IP

|    |                     |
|----|---------------------|
|    |                     |
| IP | 1-99 1300 - 1999    |
| IP | 100-199 2000 - 2699 |

### 35.2.1 IP

- 
- 
- 
- 

IP                                    1 - 99   1300 - 1999                                    IP  
   IP                                    100 - 199   2000 - 2699

### 35.2.1.1

“                                    ”

```
access-list 1 permit host 192.168.4.12
                                         192.168.4.12
                                         access-list 1 deny any
```

**Access-list 1 deny host 192.168.4.12**



“                                    ”

---

### 35.2.1.2

```
access-list 101 deny ip any any
```

```
access-list 101 permit tcp 192.168.12.0 0.0.0.255 eq telnet any
```

```
IP          192.168.12.0/24      Telnet
```

### 35.2.2 IP

- 1.
- 2.



|  |       |
|--|-------|
| Ruijie (config-xxx-nacl)# [sn] { <b>permit</b>   <b>deny</b> } {src <i>src-wildcard</i>   <b>host</b> <i>src</i>   <b>any</b> } [ <b>time-range</b> <i>tm-rng-name</i> ] | ACL , |
| Ruijie(config-xxx-nacl)# <b>exit</b><br>Ruijie(config)# <b>interface</b> <i>interface</i>  |       |
| Ruijie(config-if)# <b>ip access-group</b> <i>id</i> { <b>in</b>   <b>out</b> } [ <b>unreflect</b> ]  |       |



ACL ( ACE ) ACL  
 IP ACL ACL unreflect ACL  
 ACL a.  
 destination-IP , protocol source-IP ,  
 source-port,destination-port b.

---

### 35.2.3 IP

Ruijie# **show access-lists** [ *id* | *name* ]

### 35.2.4 IP

- Switch A Switch B 1-3

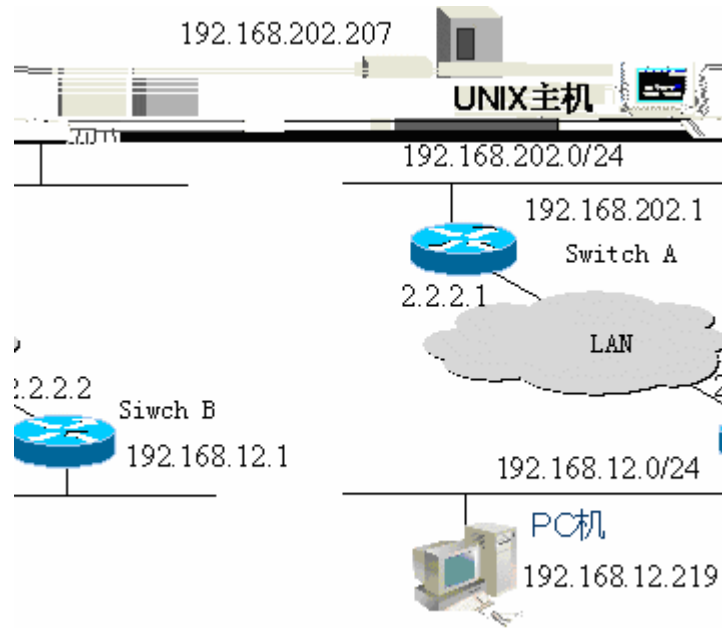

3

Switch B

1. 192.168.12.0/24 UNIX TELNET  
PING
2. Switch B 192.168.202.0/24



Switch B

```
Ruijie(config)# interface GigabitEthernet 0/1
Ruijie(config-if)# ip address 192.168.12.1 255.255.255.0
Ruijie(config-if)# exit
Ruijie(config)# interface GigabitEthernet 0/2
Ruijie(config-if)# ip address 2.2.2.2 255.255.255.0
Ruijie(config-if)# ip access-group 101 in
Ruijie(config-if)# ip access-group 101 out

101
Ruijie(config)# access-list 101 permit tcp 192.168.12.0 0.0.0.255 any
eq telnet time-range check
```

```
Ruijie(config)# access-list 101 deny icmp 192.168.12.0 0.0.0.255
```

- VLAN ID

Expert

2700 -2899

MAC

VLAN ID

Expert

### 35.3.2 Expert

Expert

1. Expert

2. ( )

Expert



```

Ruijie(config-exp-nacl)# exit
Ruijie(config)# interface gigabitEthernet 0/1
Ruijie(config-if)# expert access-group expert-list in
Ruijie(config-if)# end
Ruijie# show access-lists
expert access-list extended expert-list
petmit ip vid 20 any host 0013.2049.8272 any any
deny any any
Ruijie#
    
```

### 35.4 TCP Flag

|          |          |          |           |
|----------|----------|----------|-----------|
| TCP Flag |          | TCP Flag | Match-All |
|          | TCP Flag | TCP Flag | ACL       |
|          | ACL      |          | TCP Flag  |
|          | TCP Flag |          |           |

**permit tcp any any match-all rst**

TCP Flag RST                      0

 .

|       |     |     |     |     |
|-------|-----|-----|-----|-----|
|       | ACL | ACL | TCP | MAC |
| IP    |     |     |     |     |
| NPE80 |     |     |     |     |

TCP Flag

|  |       |
|--|-------|
|  |       |
| Ruijie(config)# <b>ip access-list extended</b> { id   name }   |       |
| Ruijie(config-ext-nacl)# [sn]<br>[permit   deny] tcp source<br>source-wildcard [ operator port [port] ]<br>destination destination-wildcard<br>[operator port [ port ]]<br>[match-all flag-name][precedence<br>precedence] | ACL , |

|   |  |
|---|--|
| Ruijie(config-exp-nacl)# <b>exit</b><br>Ruijie(config)# <b>interface</b> <i>interface</i>           |  |
| Ruijie(config-if)# <b>ip access-group</b><br>{ <i>id</i>   <i>name</i> } { <b>in</b>   <b>out</b> } |  |

## TCP Flag

1) enable

```
Ruijie> enable
Ruijie#
```

2)

```
Ruijie# configure terminal
Ruijie(config)#
```

3) ACL

```
Ruijie(config)# ip access-list extended test-tcp-flag
Ruijie(config-ext-nacl)#
```

4) ACL

```
Ruijie(config-ext-nacl)# permit tcp any any match-all rst
```

5) deny

```
Ruijie(config-ext-nacl)# deny tcp any any match-all fin
```

6)

7) end

```
Ruijie(config-ext-nacl)# end
```

8) 8

```
Ruijie# show access-list test-tcp-flag
ip access-lists extended test-tcp-flag
10 permit tcp any any match-all rst
20 deny tcp any any match-all fin
```

## 35.5

## ACL

ACE

ACL

ACL

ACE

-

- ACE
- ACE
- ACE ACE ACE
- ACE
- ACL

**ip access-list resequence** {acl-id| acl-name} sn-start sn-inc

|          |     |         |     |     |
|----------|-----|---------|-----|-----|
| ACL list | ace | tst_acl | ACL | ace |
|----------|-----|---------|-----|-----|

```
ace1: 10
ace2: 20
ace3: 30
```

**ip access-list resequence** *tst\_acl 100 3*, ACE

```
Ruijie(config)# ip access-list resequence tst_acl 100 3
ace1: 100
ace2: 103
ace3: 106
```

sn-num ace4

```
Ruijie(config-std-nacl)# permit
ace1: 100
ace2: 103
ace3: 106
ace4: 109
```

seq-num = 105 ace5

```
Ruijie(config-std-nacl)# 105 permit
ace1: 100
ace2: 103
ace5: 105
ace3: 106
ace4: 109
```

|   |     |
|---|-----|
| 4 | ace |
|---|-----|

ACE

```
Ruijie(config-std-nacl)# no 106
ace1: 100
ace2: 103
ace5: 105
```

ace4: 109

Time Range

```

ACL                                     HTTP
-----
Ruijie(config)# time-range no-http
Ruijie(config-time-range)# periodic weekdays 8:00 to 18:00
Ruijie(config)# end
Ruijie(config)# ip access-list extended limit-udp
Ruijie(config-ext-nacl)# deny tcp any any eq www time-range no-http
Ruijie(config-ext-nacl)# exit
Ruijie(config)# interface gigabitEthernet 0/1
Ruijie(config-if)# ip access-group no-http in
Ruijie(config)# end
Time Range                               :

Ruijie# show time-range
time-range entry: no-http(inactive)
periodic Weekdays 8:00 to 18:00
time-range entry: no-udp
periodic Tuesday 15:30 to 16:30
    
```

### 35.7

#### 35.7.1 TCP

TCP Flag                      ACL

35.7.1.1



35.7.1.2

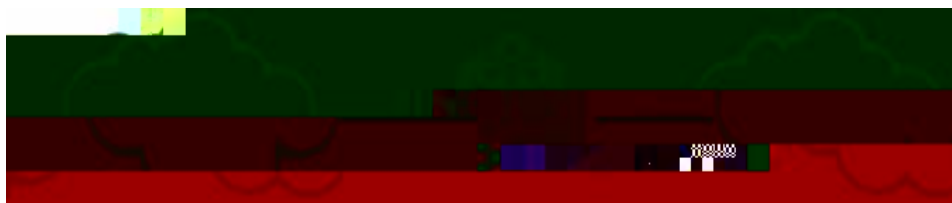

```

                                4
                                A      G3/1      B
G3/2

```

35. 7. 1. 3

```

      B      A      TCP      B
G3/2      TCP      TCP      TCP
TCP      SYN      ACK      0
Match-all      G3/2      TCP      SYN      1
ACK      0      A      B

```

35. 7. 1. 4

1)

#

Ruijie# **configure terminal**

#

ACL101

Ruijie(config)# **ip access-list extended 101**# **TCP Flag SYN=1 ACK 0**Ruijie(config-ext-nacl)# **deny tcp any any match-all syn**

#

IP

Ruijie(config-ext-nacl)# **permit ip any any**

2)

#

Ruijie(config-ext-nacl)# **exit**

#

G3/2

Ruijie(config)# **interface gigabitEthernet 3/2**# **ACL 101 G3/2**Ruijie(config-if)# **ip access-group 101 in**

3)

#

**show**

ACL

```
Ruijie# show access-lists 101  
  
ip access-list extended 101  
10 deny tcp any any match-all syn  
20 permit ip any any
```

## **36 RPL**

### **36.1 RPL**

#### **36.1.1 RPL**

RPL reverse path limited

---

# 37

## 37.1

- 1 CPU
- 2 CLI
- 3

---

## Classify

1. **protocol sub-interface**

2. **manage sub-interface**  
arp

ftp telnet snmp

3. **data sub-interface**

icmp



**SCPP** Segregate Control Plane Protection

**Glean-CAR**

- Glean-CAR
- ARP-CAR
- Port-Filter
- MPP
- ACP
- 

|      |           |         |             |     |
|------|-----------|---------|-------------|-----|
| SCPP | Glean-CAR | ARP-CAR | Port-Filter | MPP |
| ACPP |           |         |             |     |

### 37.2.2 control-plane

| control-plane | control-plane |
|---------------|---------------|
| control-plane | control-plane |
| control-plane | exit          |

### 37.2.3 SCPP

| SCPP  | SCPP  |
|---|---|
| SCPP  | SCPP  |
| SCPP  | acl_no<br>pps   |
| Ruijie(config-cp)# <b>scpp list</b> <i>acl_no</i> { <b>bw-rate</b><br><i>bw-rate</i> <b>bw-burst-rate</b> <i>bw-burst-rate</i>  <br><b>conn-total</b> <i>conn-num</i>   <b>conn-create-rate</b><br><i>conn-create-rate</i> <b>conn-create-burst-rate</b><br><i>conn-create-burst-rate</i> } | acl_no acl scpp<br>bw-rate pps<br>bw-burst-rate pps<br>conn-num<br>conn-create-rate<br>/s<br>conn-create-burst-rate<br>/s |

|   |      |
|---|------|
| Ruijie(config-cp)# <b>no scpp list</b> acl_no | SCPP |
|---|------|

SCPP

SCPP

SCPP

### 37.2.4 Glean-CAR

IP

Glean-CAR

|   |   |
|---|---|
| Ruijie(config-cp)# <b>glean-car</b><br><i>packet_rate_per_group</i> | Glean<br><i>packet_rate_per_group</i> pps |
| Ruijie(config-cp)# <b>no glean-car</b>                              | Glean-CAR                                 |

Glean-CAR

data

N N

Glean-CAR

Glean

A 192.168.52.57 B 192.168.60.57

C 172.16.0.5 172.16.0.5 ARP

*glean-car* 5 A B 5

IP ARP

Glean-CAR

Glean

5pps

### 37.2.5 ARP-CAR

ARP

ARP-CAR

|   |   |
|---|---|
| Ruijie(config-cp)# <b>arp-car</b><br><i>packet_rate_per_group</i> | ARP<br><i>packet_rate_per_group</i> pps |
| Ruijie(config-cp)# <b>no arp-car</b>                              | ARP-CAR                                 |

ARP-CAR

manage

N N

---

ARP-CAR

ARP

A

---

|  |  |
|--|--|
|  |  |
| Ruijie(config-cp)# <b>acpp bw-rate</b> <i>rate</i><br><b>bw-burst-rate</b> <i>burst-rate</i> | ACPP<br><i>rate</i> pps<br><i>burst-rate</i> pps |
| Ruijie(config-cp)# <b>no acpp</b>  | ACPP   |

ACPP

ACPP

### 37.2.9

control-plane

/-

---

---

Ruijie(config-cp)# **port-filter**

// MPP gi0/0 telnet snmp

Ruijie(config-cp)# management-interface gi0/0 allow telnet snmp

---

# 38

## 38.1 ip-mac

### 38.1.1 ip-mac

IP/MAC

---

Ipmacbind

---

IP

IP

## 38.2.2

### 38.2.2.1

#### ip ingress-filter

```
Ruijie(config-if)# ip ingress-filter log
```

```
ip ingress-filter no
```

```
Ruijie(config-if)# no ip ingress-filter log
```

### 38.2.2.2

ip-mac

show ip ingress-filter

```
Ruijie(config)# show ip ingress-filter
Firewall Network-ingress-filter is enable, blocked 0 flows
Interface GigabitEthernet 1/0: log is on, blocked 0 flows
```

## 38.3 TCP SYN

### 38.3.1 TCP SYN

|             |           |         |           |     |
|-------------|-----------|---------|-----------|-----|
| SYN         | SYN Flood | TCP SYN | SYN flood | TCP |
| TCP SYN ACK |           | ,       | TCP ACK   | TCP |
|             |           |         |           | 3   |
| SYN         |           | /       |           | TCP |

---

## 38.3.2 TCP SYN

### 38.3.2.1 TCP SYN

```

TCP SYN
acl
TCP SYN
Ruijie(config)# access-list 100 permit ip 192.168.52.0 0.0.0.255 any
ip tcp-intercept list in|out
acl
TCP SYN
Ruijie(config)# interface gigabitEthernet 0/0
Ruijie(config-if)# ip tcp-intercept list 100 in log
gi 0/0
acl 100
TCP SYN
TCP SYN
ip tcp-intercept list in|out no
Ruijie(config)# interface gigabitEthernet 0/0
Ruijie(config-if)# no ip tcp-intercept list 100 in log
```

### 38.3.2.2 TCP SYN

```

TCP SYN
show ip tcp-intercept
Ruijie(config-if)# show ip tcp-intercept
Intercepting new connections using access-list 100 at
```

---

## 38.4.2

config

!CAPB2CÅB

---

mms

```
Ruijie(config)# interface gigabitEthernet 0/0
```

```
Ruijie(config-if)# ip inspect abc in
```

```
Ruijie(config)# show ip inspect all
```

```
Inspection Rule Configuration
```

```
Inspection name abc
```

```
ftp
```

```
mms
```

```
Inspection name 123
```

```
mms
```

```
h323
```

```
Interface Configurationn
```

```
Interface gigabitEthernet 0/0
```

```
Inbound inspection rule is abc
```

```
ftp
```

```
mms
```

```
Ruijie(config)# interface gigabitEthernet 0/0
```

```
Ruijie(config-if)# ip inspect 123 in
```

```
Ruijie(config)# show ip inspect all
```

```
Inspection Rule Configuration
```

```
Inspection name abc
```

```
ftp
```

```
mms
```

```
Inspection name 123
```

```
mms
```

```
h323
```

```
Interface Configurationn
```

```
Interface gigabitEthernet 0/0
```

```
Inbound inspection rule is 123
```

```
mms
```

```
h323
```

## 38.5 TCP

### 38.5.1 TCP

---

TCP

TCP

TCP

## **38.5.2 TCP**

38.5.2.1

TCP

4

i

---

gi0/0

in

---

```
-----  
Output  
no session-limit access-group 1 rate 12 concurrent 123  
out log  
==[ Show Cmd to del the rule on the gigabitEthernet 0/0's end ]=
```

### 38.6.3.3 show session-limit statistics

```
Ruijie(config-if)# show session-limit statistics  
  
=====[ Show gigabitEthernet 0/0's Statistics ]=====  
Input  
matches access-group : 1  
[Configure]: new_session_rate : 12 , concurren : 123  
[Statistics]: conformed 2247 sessions, blocked 0 sessions  
  
matches access-group : 12  
[Configure]: new_session_rate : 20 , concurren : 100  
[Statistics]: conformed 0 sessions, blocked 0 sessions  
  
matches access-group : 13  
[Configure]: new_session_rate : 20 , concurren : 100  
[Statistics]: conformed 0 sessions, blocked 0 sessions  
  
matches access-group : 14  
[Configure]: new_session_rate : 20 , concurren : 100  
[Statistics]: conformed 0 sessions, blocked 0 sessions  
  
-----  
Output  
matches access-group : 1  
[Configure]: new_session_rate : 12 , concurren : 123  
[Statistics]: conformed 0 sessions, blocked 0 sessions  
  
=====[ Show gigabitEthernet 0/0's Statistics End ]=====
```

## 38.7

### 38.7.1

flood     udp flood

icmp



---

TCP                    TCP                    ICMP  
TCP                    SYN                    ICMP                    ip session

**track-state-strictly**

---

 . . . .

**ip session track-state-strictly**      FW

TCP                    TCP                    telnet    ftp

---

# 39 VPDN

## 39.1 VPDN

VPDN                      L2TP    PPTP

- L2TP(Layer Two Tunneling Protocol)
- PPTP(Point-to-Point Tunneling Protocol)

|                   |                 |      |       |
|-------------------|-----------------|------|-------|
| VPDN              |                 |      | PPTP  |
| MicroSoft Windows |                 | L2TP | Cisco |
| L2TP              | Windows 2000/XP |      |       |



# 40 PPTP

## 40.1 PPTP

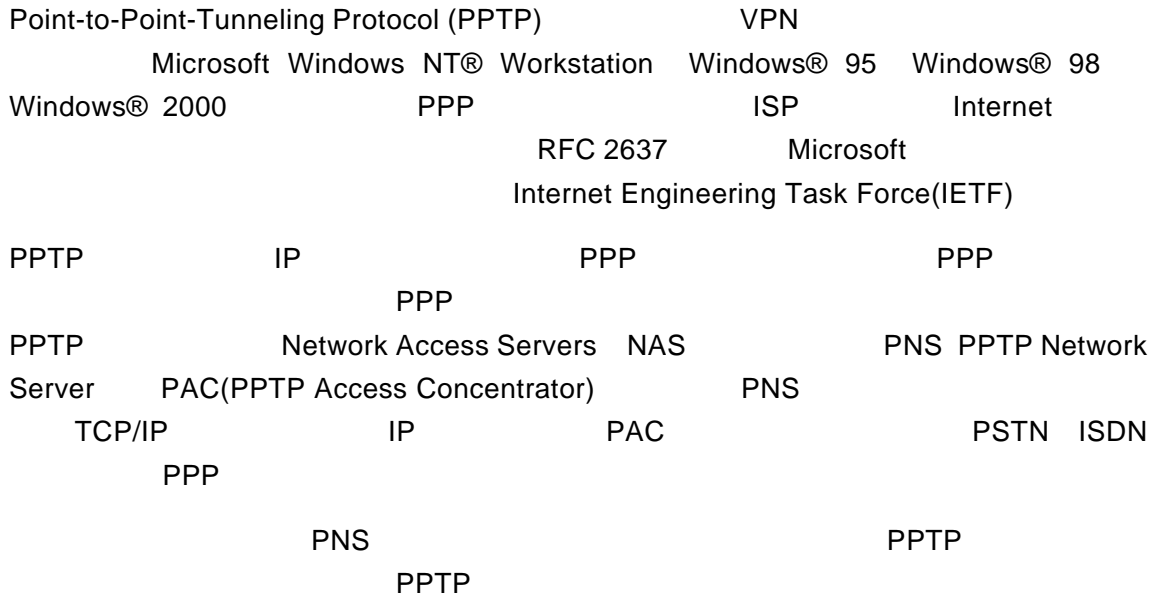

## 40.2 PPTP

### 40.2.1

- ( )
- ( )
- VPDN ( )
- Virtual-template ( )
- VPDN-group( )

### 40.2.2

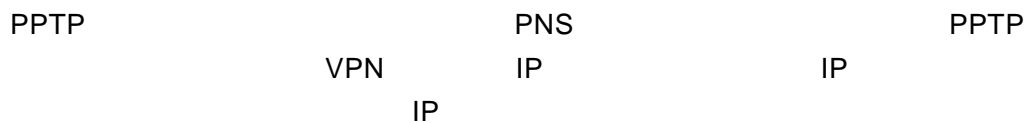





### 40.2.5.1 virtual-template

#### Virtual-template

| Ruijie(config)# <b>interface virtual-template</b><br><i>number</i>           | / Virtual<br>-template |
|--|------------------------|
| Ruijie(config)# <b>no interface</b><br><b>virtual-template</b> <i>number</i> | Virtual- template      |

*number*                  Virtual-template                  Virtual-template  
PPTP                  Virtual-access

### 40.2.6 VPDN-group

#### PPTP

#### VPDN-group

#### VPDN-group

- VPDN-group( )
- ( )
- ( )
- ( )
- ( )
- ( )
- VPDN-group ( )
- PPTP ( )
- PPTP ( )

### 40.2.6.1 VPDN-group

#### VPDN-group

| Ruijie(config)# <b>vpdn-group</b> <i>name</i>    | / VPDN-group |
|--|--------------|
| Ruijie(config)# <b>no vpdn-group</b> <i>name</i> | VPDN-group   |

*name*

VPDN-group

VPDN-group

## 40.2.6.2

| Ruijie (config- <i>vpdn</i> )# <b>accept-dialin</b>    |  |
|--|--|
| Ruijie (config- <i>vpdn</i> )# <b>no accept-dialin</b> |  |

PNS

## 40.2.6.3

| Ruijie(config- <i>vpdn-acc-in</i> )# <b>protocol</b> { <b>any</b>   <b>l2tp</b>   <b>pptp</b> } |  |
|---|--|
| Ruijie(config- <i>vpdn-acc-in</i> )# <b>no protocol</b>   |  |

PNS

40.2.6.5

VPDN-group  
 VPDN-group VPDN-group VPDN  
 VPDN-group  
 VPDN-group

|   |  |
|---|--|
|   |  |
| Ruijie(config-vpdn)# <b>terminate-from hostname</b> <i>name</i> |  |
| Ruijie(config-vpdn)# <b>no terminate-from hostname</b>          |  |

*name*

|  |  |
|--|--|
|  |  |
| Ruijie(config-vpdn)# <b>local name</b> <i>name</i> |  |
| Ruijie(config-vpdn)# <b>no local</b> <i>name</i>   |  |

*name*

40.2.6.6 VPDN-group

VPDN-group  
 VPDN-group

|   |            |
|---|------------|
|   |            |
| Ruijie(config-vpdn)# <b>source-ip</b> <i>src-ip</i> | VPDN-group |
| Ruijie(config-vpdn)# <b>no source-ip</b>            | VPDN-group |

*src-ip* VPDN-group

40.2.6.7 PPTP

PPTP

|  |                          |
|--|--------------------------|
|  |                          |
| Ruijie(config-vpdn)# <b>pptp flow-control receive-window winsize</b> | PPTP<br>1—64             |
| Ruijie(config-vpdn)# <b>no pptp flow-control receive-window</b>      | PPTP<br>PAC<br>16 PNS 64 |
| Ruijie(config-vpdn)# <b>pptp flow-control static-rtt interval</b>    | PPTP<br>ACK<br>100—5000  |

Ruijie(config-vpdn)# **no pptp**

**flow-control receive-window**

PPTP

IP

IP

R3660

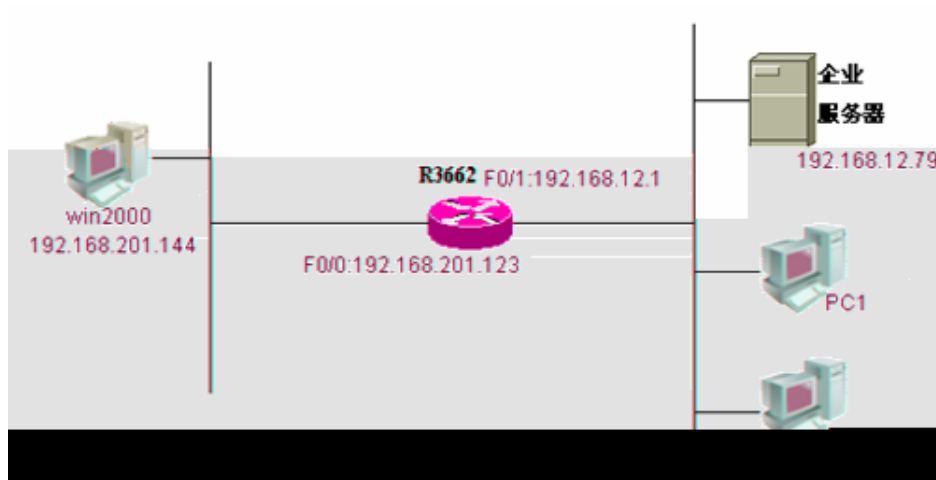

1

PPTP

R3660



```
Description . . . . . : STAR 901 Family Fast Ethernet
r (ACPI)
Physical Address. . . . . : 00-D0-F8-00-68-E5
DHCP Enabled. . . . . : No
IP Address. . . . . : 192.168.201.144
Subnet Mask . . . . . : 255.255.255.0
Default Gateway . . . . . : 192.168.201.123
DNS Servers . . . . . : 202.101.143.141
Primary WINS Server . . . . . : 192.168.9.7
```

```
F:\>route print
```

```
=====
```

```
Interface List
```

```
0x1 ..... MS TCP Loopback interface
```

```
0x2 ...00 d0 f8 00 68 e5 ..... PCI Bus Master Adapter
```

```
=====Active
```

```
Routes:
```

| Network         | Destination     | Netmask         | Gateway         | Interface | Metric |
|-----------------|-----------------|-----------------|-----------------|-----------|--------|
| 0.0.0.0         | 0.0.0.0         | 192.168.201.123 | 192.168.201.144 |           | 1      |
| 127.0.0.0       | 255.0.0.0       |                 | 127.0.0.1       | 127.0.0.1 | 1      |
| 192.168.201.0   | 255.255.255.0   | 192.168.201.144 | 192.168.201.144 |           | 1      |
| 192.168.201.144 | 255.255.255.255 | 127.0.0.1       | 127.0.0.1       |           | 1      |
| 192.168.201.255 | 255.255.255.255 | 192.168.201.144 | 192.168.201.144 |           | 1      |
| 224.0.0.0       | 224.0.0.0       | 192.168.201.144 | 192.168.201.144 |           | 1      |
| 255.255.255.255 | 255.255.255.255 | 192.168.201.144 | 192.168.201.144 |           | 1      |

```
Default Gateway: 192.168.201.123
```

```
=====
```

```
Persistent Routes:
```

```
None
```

```
Win2000 " " " " " Internet
" " " " " 192.168.201.123
Vpdnconnect Vpdnconnect VPDN PPTP
PAP
```

```
PC 1111
```

```
Win2000
```

```
192.168.12.79
```

```
F:\>ipconfig /all
```

```
Windows 2000 IP Configuration
```

```
Host Name . . . . . : testpc
```

PPTP

```
192.168.201.123 255.255.255.255 192.168.201.144 192.168.201.144
1
192.168.201.144 255.255.255.255          127.0.0.1          127.0.0.1
1
192.168.201.200 255.255.255.255 192.168.201.100 192.168.201.144
1
192.168.201.255 255.255.255.255 192.168.201.144 192.168.201.144
1
224.0.0.0      224.0.0.0      1.1.1.4      1.1.1.4      1
224.0.0.0 224.0.0.0 192.168.201.144 192.168.201.144 1
255.255.255.255 255.255.255.255 192.168.201.144 192.168.201.144
1
```

```
Default Gateway:          192.168.12.1
```

```
=====
```

```
Persistent Routes:
```

```
None
```

```
F:\>
```

```
F:\>ping 192.168.12.1
```

```
Pinging 192.168.12.1 with 32 bytes of data:
```

```
Reply from 192.168.12.1: bytes=32 time<10ms TTL=255
```

```
Reply from 192.168.12.1: bytes=32 time<10ms TTL=255
```

```
Reply from 192.168.12.1: bytes=32 time<10ms TTL=255
```

```
Reply from 192.168.12.1: bytes=32 time<10ms TTL=255
```

```
Ping statistics for 192.168.12.1:
```

```
Packets: Sent = 4, Received = 4, Lost = 0 (0% loss),
```

```
Approximate round trip times in milli-seconds:
```

```
Minimum = 0ms, Maximum = 0ms, Average = 0ms
```

```
F:\>ping 192.168.12.79
```

```
Pinging 192.168.12.79 with 32 bytes of data:
```

```
Reply from 192.168.12.79: bytes=32 time=10ms TTL=127
```

```
Reply from 192.168.12.79: bytes=32 time<10ms TTL=127
```

```
Reply from 192.168.12.79: bytes=32 time<10ms TTL=127
```

```
Reply from 192.168.12.79: bytes=32 time<10ms TTL=127
```

```
Ping statistics for 192.168.12.79:
```

```
Packets: Sent = 4, Received = 4, Lost = 0 (0% loss),
```

```
Approximate round trip times in milli-seconds:
```

```
Minimum = 0ms, Maximum = 10ms, Average = 2ms
```

```
R3660#sh ip route
```

```
Codes: C - connected, S - static, R - RIP
```

```
O - OSPF, IA - OSPF inter area
```

```

E1 - OSPF external type 1, E2 - OSPF external type 2
Gateway of last resort is 0.0.0.0 to network 0.0.0.0
1.0.0.0/8 is variably subnetted, 2 subnets, 2 masks
C      1.1.1.0/24 is directly connected, Virtual-Access1
C      1.1.1.4/32 is directly connected, Virtual-Access1
C     192.168.12.0/24 is directly connected, GigabitEthernet0/1
C     192.168.201.0/24 is directly connected, GigabitEthernet0/0
S*    0.0.0.0/0 is directly connected, GigabitEthernet0/0
R3660#
    
```

VPDN

192.168.12.1

## 40.2.8 PPTP

### 40.2.8.1 PPTP

**show vpdn**

|                                  |                        |
|----------------------------------|------------------------|
|                                  |                        |
| Ruijie# <b>show vpdn tunnel</b>  | VPDN Tunnel            |
| Ruijie# <b>show vpdn session</b> | VPDN Session           |
| Ruijie# <b>show vpdn</b>         | VPDN Tunnel    Session |

```

R3660# sh vpdn
%No active L2TP tunnels
PPTP Tunnel and Session Information Total tunnels 1 sessions 1
LocID Remote Name      State      Remote Address  Port  Sessions
1
1
LocID RemID TunID Intf  Username      State      Last Chg
1     49152 1     Vi1   pc            connected  00:31:33
R3660#
    
```

L2TP    PPTP

|          |                |      |       |             |       |                            |  |  |  |
|----------|----------------|------|-------|-------------|-------|----------------------------|--|--|--|
|          |                |      |       |             |       | Total tunnels 1 sessions 1 |  |  |  |
|          |                | ID   | LocID | Remote Name |       | State                      |  |  |  |
| IP       | Remote Address | PPTP | TCP   | Port        |       |                            |  |  |  |
| Sessions |                | ID   | LocID | ID          | RemID |                            |  |  |  |

|          |    |         |                |      |
|----------|----|---------|----------------|------|
|          | ID | TunID   | Virtual-Access | Intf |
| Username |    | (State) | Last Chg       |      |

### 40.2.8.2 PPTP

#### clear vpdn

|   |  |
|---|--|
|   |  |
| Ruijie# <b>clear vpdn tunnel</b><br>[ [l2tp   pptp] [remote name] ] |  |

*remote name*

**clear vpdn tunnel pptp**      **clear vpdn tunnel**

```
R3660# show vpdn
%No active L2TP tunnels
%No active PPTP tunnels
```

#### debug vpdn

PPTP

#### debug ppp

PPP

|  |  |  |      |  |       |       |        |
|--|--|--|------|--|-------|-------|--------|
|  |  |  |      |  |       |       |        |
| Ruijie# <b>debug vpdn [ error   event   packet ]</b> | <table border="0"> <tr> <td></td> <td>VPDN</td> </tr> <tr> <td></td> <td>    Error</td> </tr> <tr> <td>Event</td> <td>    Packet</td> </tr> </table> |  | VPDN |  | Error | Event | Packet |
|  | VPDN   |  |      |  |       |       |        |
|  | Error  |  |      |  |       |       |        |
| Event  | Packet   |  |      |  |       |       |        |



Debug

---

PPTP

#### debug vpdn event

```
VPDN: Pptp rcv start-control-connection-request from host
192.168.200.114
PPTP: New tunnel socket id =9
VPDN: Pptp get tunnel info for 192.168.200.114 ok!
VPDN: Pptp send start-control-connection-reply, ok
VPDN: Pptp tunnel id 0 state change: idle --> estbed
PPTP: Add send-echo-request timer, interval = 60
```



Phone Number:

Subaddress:

PPTP: O Outgoing-Call-Reply len 32 Magic Cookie 0x1A2B3C4D

Call Id 0x1

Peer Call Id 0x4000

Result Code 0x1

Error Code 0x0

Cause Code 0x0

Connect Speed 0xFA00

Rec Window Size 0x10

Physical Channel Id 0x0

PPTP: I Set-Link-Info len 24 Magic Cookie 0x1A2B3C4D

Peer Call Id 0x1

Send ACCM 0xFFFFFFFF

Recv ACCM 0xFFFFFFFF

%UPDOWN: Interface Virtual-Access1, changed state to up

VPDN: PPTP session Virtual-Access1 wait pak ack timeout(wait seq=39,  
ack=36), de  
crease send window to half of current = 8!  
VPDN: PPTP session Virtual-Access1 adjust ATO to 400 ms!  
VPDN: Pptp EGRE encap fail, err=-4!  
VPDN: PPTP session Virtual-Access1 wait pak ack timeout(wait seq=40,  
ack=36), de  
crease send window to half of current = 4!

# 41 L2TP

## 41.1 L2TP

Layer 2 Tunnel Protocol(L2TP) Internet Engineering Task Force(IETF)  
Cisco Layer 2 Forwarding(L2F) Point-to-Point Tunneling  
Protocol (PPTP) RFC  
2661

L2TP Point-to-Point Protocol(PPP) PPP  
PPTP L2TP UDP

L2TP VPN

L2TP  
L2TP-class

L2TP

- L2TP-class
- L2TP
- L2TP
- L2TP

41.2.2.1 l2tp-class

L2TP

L2TP-class

| Ruijie(config)# <b>l2tp-class</b> <i>l2tp-class-name</i>    | /<br>L2TP-class |
|---|-----------------|
| Ruijie(config)# <b>no l2tp-class</b> <i>l2tp-class-name</i> | L2TP-class      |

L2TP-class-name / L2TP-class  
Pseudowire-class

L2TP-class

41.2.2.2 L2TP

L2TP

| Ruijie(config-l2tp-class)# <b>receive-window</b> <i>size</i> |  |
|--|--|
| Ruijie(config-l2tp-class)# <b>no receive-window</b>          |  |

Ruijie(config-l2tp-class)# **retransmit** {initial  
{retries *initial-retries* | timeout { *size* {

|   |  |
|---|--|
| Ruijie(config-l2tp-class)# <b>timeout setup</b><br><i>seconds</i> |  |
| Ruijie(config-l2tp-class)# <b>no timeout setup</b>                |  |

*size* 8 *initial-retries* SCCRQ  
 2 *initial-timeout* SCCRQ 1  
 8 *retries* 5 *timeout*  
 8 *seconds* (Tunnel) 120

41.2.2.3 L2TP

L2TP (Tunnel)

|  |  |
|--|--|
|  |  |
| Ruijie(config-l2tp-class)# <b>authentication</b>             |  |
| Ruijie(config-l2tp-class)# <b>no authentication</b>          |  |
| Ruijie(config-l2tp-class)# <b>no hostname</b>                |  |
| Ruijie(config-l2tp-class)# <b>hostname</b> <i>host-name</i>  |  |
| Ruijie(config-l2tp-class)# <b>password</b> <i>pass-words</i> |  |
| Ruijie(config-l2tp-class)# <b>no password</b>                |  |

*pass-words* *host-name*

41.2.2.4 L2TP

(Tunnel)

|   |  |
|---|--|
|   |  |
| Ruijie(config-l2tp-class)# <b>hello</b> <i>interval</i> |  |

### 41.2.3 **pseudowire-class**

L2TP

L2TP

|  |        |
|--|--------|
|  |        |
| Ruijie (config-pw-class)# <b>ip dfbit set</b>                        |        |
| Ruijie (config-pw-class)# <b>no ip dfbit set</b>                     |        |
| Ruijie (config-pw-class)# <b>ip ttl ttl-value</b>                    | IP TTL |
| Ruijie (config-pw-class)# <b>no ip ttl</b>                           | TTL    |
| Ruijie (config-pw-class)# <b>ip local interface interface-name</b>   | ( )    |
| Ruijie(config-pw-class)# <b>no ip local interface interface-name</b> | ( )    |

L2TP IP L2TP UDP IP  
TTL 255  
( )

#### 41.2.3.4 L2TP

#### L2TP

|   |      |
|---|------|
|   |      |
| Ruijie(config)# <b>protocol l2tpv2</b><br>[l2tp-class-name] | L2TP |
| Ruijie(config)# <b>no protocol</b>                          |      |

L2TPv2 RFC 2661 L2TP  
L2TP-class-name L2TP-class  
L2TP

#### 41.2.4 virtual-ppp

#### L2TP

#### L2TP

#### Virtual-ppp

- Virtual-ppp
- IP
- 
- Pseudowire

IP

41.2.4.1

virtual-ppp

L2TP

Virtual-ppp

|  |            |
|--|------------|
| Ruijie (config-if)# <b>no pseudowire</b> | Pseudowire |
|--|------------|

virtual-ppp

Pseudowire

virtual-ppp

```
l2tp-class l2x
hostname branch
!
pseudowire-class pw
encapsulation l2tpv2
protocol l2tpv2 l2x
ip local interface Gig22C/24 pw
!
p(cal)6( i)6(Gig)6(22C/24)6( )]TJ0 -1.1 -1.herrancet 0/pw)lTc T*(! )tocol iTJ
```

```
!  
!  
end  
  
"Branch" ( NAT ) virtual-ppp 1  
"Headquarters" L2TP Tunnel "Branch"  
( NAT ) interface GigabitEthernet 0/1 Internet  
ACL(Access Control List)
```

## 2)Windows 2000 Server :

```
Microsoft Windows 2000 [Version 5.00.2195]
```

```
(C) 1985-2000 Microsoft Corp.
```

```
C:\>ipconfig /all
```

```
Windows 2000 IP Configuration
```

```
Host Name . . . . . : BLIZZARD
```

```
Primary DNS Suffix . . . . . :
```

```
Node Type . . . . . : Broadcast
```

```
IP Routing Enabled. . . . . : Yes
```

```
WINS Proxy Enabled. . . . . : No
```

```
Ethernet adapter 2:
```

```
Connection-specific DNS Suffix . :
```

```
Description . . . . . : NE2000 Compatible
```

```
Physical Address. . . . . : 00-10-88-01-A5-C3
```

```
DHCP Enabled. . . . . : No
```

```
IP Address. . . . . : 192.168.12.213
```

```
Subnet Mask . . . . . : 255.255.255.0
```

```
Default Gateway . . . . . : 192.168.12.1
```

```
DNS Servers . . . . . : 202.101.143.141
```

```
PPP adapter RAS Server (Dial In) Interface:
```

```
Connection-specific DNS Suffix . :
```

```
Description . . . . . : WAN (PPP/SLIP) Interface
```

```
Physical Address. . . . . : 00-53-45-00-00-00
```

```
DHCP Enabled. . . . . : No
```

```
IP Address. . . . . : 192.168.103.2
```

```
Subnet Mask . . . . . : 255.255.255.255
```

```
Default Gateway . . . . . :
```

```
DNS Servers . . . . . :
```

```
C:\>route print
```

```
=====
```

```
Interface List
```

```
0x1 . . . . . MS TCP Loopback interface
```

---

```
0x1000002 ...00 53 45 00 00 00 ..... WAN (PPP/SLIP) Interface
0x1000003 ...00 10 88 01 a5 c3 ..... Novell 2000 Adapter.
=====
Active Routes:
Network Destination          Netmask          Gateway          Interface
Metric
0.0.0.0      0.0.0.0      192.168.12.1  192.168.12.213    1
127.0.0.0    255.0.0.0    127.0.0.1    127.0.0.1        1
192.168.12.0 255.255.255.0 192.168.12.213 192.168.12.213
1
192.168.12.213 255.255.255.255      127.0.0.1      127.0.0.1
1
192.168.12.217 255.255.255.255  192.168.12.213 192.168.12.213
1
192.168.12.255 255.255.255.255  192.168.12.213 192.168.12.213
1
192.168.103.2 255.255.255.255      127.0.0.1      127.0.0.1
1
192.168.103.6 255.255.255.255  192.168.103.2  192.168.103.2
1
224.0.0.0    224.0.0.0    192.168.12.213 192.168.12.213    1
255.255.255.255 255.255.255.255  192.168.12.213 192.168.12.213
1
Default Gateway:          192.168.12.1
=====
Persistent Routes:
None
C:\>

                                Windows 2000 Server      "
VPDN                            (    ACL
```

L2TP



|  |  |
|--|--|
|  |  |
|--|--|

```

192.168.201.64 255.255.255.192 192.168.201.78 192.168.201.78
1
192.168.201.78 255.255.255.255 127.0.0.1 127.0.0.1
1
192.168.201.255 255.255.255.255 192.168.201.78 192.168.201.78
1
224.0.0.0 224.0.0.0 192.168.201.78 192.168.201.78 1
255.255.255.255 255.255.255.255 192.168.201.78
192.168.201.78 1
Default Gateway: 192.168.201.1

```

```
=====
```

Persistent Routes:

| Network Address | Netmask       | Gateway Address | Metric |
|-----------------|---------------|-----------------|--------|
| 192.168.2.0     | 255.255.255.0 | 192.168.1.1     | 1      |
| 192.168.9.0     | 255.255.255.0 | 192.168.12.1    | 1      |
| 61.154.22.0     | 255.255.255.0 | 192.168.12.1    | 1      |

```
C:\WINNT\system32>ping 192.168.12.1
```

Pinging 192.168.12.1 with 32 bytes of data:

```
Reply from 192.168.12.1: bytes=32 time=50ms TTL=254
```

```
Reply from 192.168.12.1: bytes=32 time=20ms TTL=254
```

```
Reply from 192.168.12.1: bytes=32 time<10ms TTL=254
```

```
Reply from 192.168.12.1: bytes=32 time=60ms TTL=254
```

Ping statistics for 192.168.12.1:

Packets: Sent = 4, Received = 4, Lost = 0 (0% loss),

Approximate round trip times in milli-seconds:

Minimum = 0ms, Maximum = 60ms, Average = 32ms

```
C:\WINNT\system32>ping 192.168.103.2
```

Pinging 192.168.103.2 with 32 bytes of data:

```
Reply from 192.168.103.2: bytes=32 time<10ms TTL=128
```

```
Reply from 192.168.103.2: bytes=32 time<10ms TTL=128
```

```
Reply from 192.168.103.2: bytes=32 time<10ms TTL=128
```

```
Reply from 192.168.103.2: bytes=32 time<10ms TTL=128
```

Ping statistics for 192.168.103.2:

Packets: Sent = 4, Received = 4, Lost = 0 (0% loss),

Approximate round trip times in milli-seconds:

Minimum = 0ms, Maximum = 0ms, Average = 0ms

```
C:\WINNT\system32>
```

```

"Branch" "DENGL-NECBOOK" Internet
"Hea./C2]TJ me<1quaCBOO

```

```

R3660# show ip nat translations
Pro Inside global      Inside local      Outside local      Outside
global
icmp 192.168.103.6:512 192.168.201.78:512 192.168.207.2:512
192.168.207.2:512
icmp 192.168.12.217:512 192.168.201.78:512 192.168.12.1:512
192.168.12.1:512
R3660# show ip route
Codes: C - connected, S - static, R - RIP
O - OSPF, IA - OSPF inter area
E1 - OSPF external type 1, E2 - OSPF external type 2
Gateway of last resort is 192.168.12.1 to network 0.0.0.0
192.168.103.0/32 is subnetted, 2 subnets
C      192.168.103.6 is directly connected, Virtual-PPP1
C      192.168.103.2 is directly connected, Virtual-PPP1
C      192.168.12.0/24 is directly connected, GigabitEthernet0/1
C      192.168.201.0/24 is directly connected, GigabitEthernet0/0
S*    0.0.0.0/0 [1/0] via 192.168.12.1, GigabitEthernet0/1
R3660#

```

#### 41.2.5.2 Cisco 2620

|      |              |             |      |       |
|------|--------------|-------------|------|-------|
|      | Ruijie       | Cisco 2620  | L2TP | Cisco |
| 2620 | L2TP Network | Server(LNS) | 3    |       |



3 Cisco 2620(LNS) L2TP

R3660 Cisco2620

1)R3660

```

R3660# show running-config
Building configuration...
Current configuration : 1136 bytes
!

```

```
hostname R3660
access-list 1 permit any
!
l2tp-class l2x
authentication
hostname branch
password share
!
pseudowire-class pw
encapsulation l2tpv2
protocol l2tpv2 l2x
ip local interface serial1/0
!
!
!
!
!
!
interface serial 1/0
encapsulation PPP
ip address 202.101.93.21 255.255.255.192
```

```
interface Null 0
!
interface Virtual-ppp 1
pseudowire 202.101.93.23 7 pw-class pw
ppp pap sent-username rgnos password 7 072C04211A01
ip mtu 1460
ip address 192.168.103.3 255.255.255.0
!
router ospf
network 192.168.103.0 0.0.0.255 area 0.0.0.1
network 192.168.201.0 0.0.0.255 area 0.0.0.1
!
ip nat inside source list 1 interface Serial1/0 overload
ip route 0.0.0.0 0.0.0.0 serial 1/0
ip route 192.168.19.0 255.255.255.0 Virtual-ppp 1
!
line con 0
line aux 0
line vty 0 4
!
!
end
R3660#

                                "Branch"                (                )    Virtual-ppp 1
                                "Headquarters" L2TP Tunnel    "Branch"
( 0A's6S*ü
```

```
C      202.101.93.0/26 is directly connected, Serial1/0
S*    0.0.0.0/0 is directly connected, Serial1/0
R3660#show arp
Protocol Address          Age (min)  Hardware Addr  Type
Interface
Internet 192.168.201.213      3    0010.8801.a5c3  ARPA
GigabitEthernet0/0
Internet 192.168.201.1      -    00d0.f8fb.126e  ARPA
GigabitEthernet0/0
R3660#
```

## 2)Cisco2620

```
Cisco2620# show running-config
Building configuration...
Current configuration : 1212 bytes
!
version 12.2
service timestamps debug uptime
service timestamps log uptime
no service password-encryption
!
hostname Cisco2620
!
!
username 163 password 0 163
username rgnos password 0 rgnos
username 263 password 0 263
ip subnet-zero
!
!
no ip domain-lookup
!
vpdn enable
!
vpdn-group 1
! Default L2TP VPDN group
accept-dialin
protocol l2tp
virtual-template 1

!
```

```
!  
interface GigabitEthernet0/0  
ip address 192.168.19.1 255.255.255.0  
duplex auto  
speed 10  
!  
interface Serial0/0  
ip address 202.101.93.23 255.255.255.192  
encapsulation ppp  
fair-queue  
clockrate 2000000  
!  
interface Serial0/1  
no ip address  
shutdown  
!  
interface Virtual-Template1  
ip address 192.168.103.2 255.255.255.0  
ppp authentication pap  
!  
router ospf 100  
log-adjacency-changes  
network 192.168.103.0 0.0.0.255 area 1  
!  
ip classless  
ip http server  
!  
!  
voice-port 1/0/0  
!  
voice-port 1/0/1  
!  
dial-peer cor custom  
!  
!  
gatekeeper  
shutdown  
!  
!  
line con 0  
exec-timeout 0 0  
line aux 0
```



```
Primary DNS Suffix . . . . . :  
Node Type . . . . . : Broadcast  
IP Routing Enabled. . . . . : No  
WINS Proxy Enabled. . . . . : No  
  
Ethernet adapter 2:  
Connection-specific DNS Suffix . :  
Description . . . . . : NE2000 Compatible  
Physical Address. . . . . : 00-10-88-01-A5-C3  
DHCP Enabled. . . . . : No  
IP Address. . . . . : 192.168.201.213  
Subnet Mask . . . . . : 255.255.255.0  
Default Gateway . . . . . : 192.168.201.1  
DNS Servers . . . . . : 202.101.143.141
```

```
C:\>route print
```

```
=====  
Interface List  
0x1 ..... MS TCP Loopback interface  
0x3000003 ...00 10 88 01 a5 c3 ..... Novell 2000 Adapter.  
=====  
=====Active
```

```
Routes:
```

| Network         | Destination     | Netmask         | Gateway         | Interface | Metric |
|-----------------|-----------------|-----------------|-----------------|-----------|--------|
| 0.0.0.0         | 0.0.0.0         | 192.168.201.1   | 192.168.201.213 | 1         |        |
| 127.0.0.0       | 255.0.0.0       | 127.0.0.1       | 127.0.0.1       | 1         |        |
| 192.168.201.0   | 255.255.255.0   | 192.168.201.213 | 192.168.201.213 | 1         |        |
| 192.168.201.213 | 255.255.255.255 | 127.0.0.1       | 127.0.0.1       | 1         |        |
| 192.168.201.255 | 255.255.255.255 | 192.168.201.213 | 192.168.201.213 | 1         |        |
| 224.0.0.0       | 224.0.0.0       | 192.168.201.213 | 192.168.201.213 | 1         |        |
| 255.255.255.255 | 255.255.255.255 | 192.168.201.213 | 192.168.201.213 | 1         |        |

```
Default Gateway: 192.168.201.1
```

```
=====  
Persistent Routes:
```

```
None
```

```
C:\>ping 192.168.103.2
```

```
Pinging 192.168.103.2 with 32 bytes of data:
```

```
Reply from 192.168.103.2: bytes=32 time=10ms TTL=0
```

```
Reply from 192.168.103.2: bytes=32 time<10ms TTL=0
Reply from 192.168.103.2: bytes=32 time<10ms TTL=0
Reply from 192.168.103.2: bytes=32 time<10ms TTL=0
Ping statistics for 192.168.103.2:
Packets: Sent = 4, Received = 4, Lost = 0 (0% loss),
Approximate round trip times in milli-seconds:
Minimum = 0ms, Maximum = 10ms, Average = 2ms
C:\>ping 192.168.19.1
Pinging 192.168.19.1 with 32 bytes of data:
Reply from 192.168.19.1: bytes=32 time<10ms TTL=254
Reply from 192.168.19.1: bytes=32 time<10ms TTL=254
Reply from 192.168.19.1: bytes=32 time<10ms TTL=254
Reply from 192.168.19.1: bytes=32 time<10ms TTL=254
Ping statistics for 192.168.19.1:
Packets: Sent = 4, Received = 4, Lost = 0 (0% loss),
Approximate round trip times in milli-seconds:
Minimum = 0ms, Maximum = 0ms, Average = 0ms
C:\>ping 202.101.93.23
Pinging 202.101.93.23 with 32 bytes of data:
Reply from 202.101.93.23: bytes=32 time<10ms TTL=254
Reply from 202.101.93.23: bytes=32 time<10ms TTL=254
Reply from 202.101.93.23: bytes=32 time<10ms TTL=254
Reply from 202.101.93.23: bytes=32 time<10ms TTL=254
Ping statistics for 202.101.93.23:
Packets: Sent = 4, Received = 4, Lost = 0 (0% loss),
Approximate round trip times in milli-seconds:
Minimum = 0ms, Maximum = 0ms, Average = 0ms
C:\>
```

|                |            |          |
|----------------|------------|----------|
| "Branch"       | "BLIZZARD" | Internet |
| "Headquarters" | VPDN       |          |

41.2.5.3 windows 2000 hostname

Ruijie  
2000

Windows 2000 PC

PC

windows

```

ip address negotiate
!
ip route 0.0.0.0 0.0.0.0 192.168.52.1
!
ref parameter 75 400
line con 0
line aux 0
line vty 0 4
login
    
```

## 41.3

### 41.3.1

- ( )
- ( )
- VPDN ( )
- Virtual-template ( )
- Vpdn-group( )

### 41.3.2

| IP | L2TP | L2TP   | VPN | LNS<br>IP |
|----|------|--|-----|-----------|
|    |      |  |     |           |
|    |      | Ruijie(config)# <b>ip local pool</b> <i>poolname</i> <i>first-ip</i><br><i>[last-ip]</i> | /   |           |
|    |      | Ruijie(config)# <b>no ip local pool</b> <i>poolname</i>                                  |     |           |

*poolname* / *first-ip*  
*last-ip*

### 41.3.3

L2TP  
L2TP

|   |  |
|---|--|
|   |  |
| Ruijie(config)# <b>username</b> <i>user-name</i> <b>password</b> {0 7}<br><i>password</i> |  |
| Ruijie(config)# <b>no username</b> <i>user-name</i>                                       |  |

*user-name* *password*  
( )

### 41.3.4 VPDN

L2TP VPDN  
VPDN

- / VPDN
- VPDN
- , / VPDN VPDN

#### 41.3.4.1 / VPDN

L2TP L2TP VPDN VPDN

|                                       |      |
|---------------------------------------|------|
|                                       |      |
| Ruijie(config)# <b>vpdn enable</b>    | VPDN |
| Ruijie(config)# <b>no vpdn enable</b> | VPDN |

VPDN / VPDN  
L2TP

41.3.4.2 VPDN

VPDN

- VPDN-group( )
- ( )
- ( )
- ( )
- ( )
- ( )
- VPDN-group ( )
- L2TP ( )
- L2TP ( )

41.3.6.1 VPDN-group

```
VPDN-group
```

```
Ruijie(config)# vpdn-group name /
```

| Ruijie(config-vpdn-acc-in)# <b>protocol</b> { <b>any</b>   <b>l2tp</b>   <b>pptp</b> } |  |
|--|--|
| Ruijie(config-vpdn-acc-in)# <b>no protocol</b>   |  |

## 41.3.6.4

## VPDN-group

| Ruijie(config-vpdn-acc-in)# <b>virtual-template</b><br><i>number</i>    |  |
|---|--|
| Ruijie(config-vpdn-acc-in)# <b>no virtual-template</b><br><i>number</i> |  |

## VPDN-group

## 41.3.6.5

## VPDN-group

=

|  |  |
|--|--|
| Ruijie(config-vpdn)# <b>local name</b> <i>name</i> |  |
| Ruijie(config-vpdn)# <b>no local name</b>          |  |

*name*

#### 41.3.6.7 VPDN-group

VPDN-group  
VPDN-group

|   |            |
|---|------------|
|   |            |
| Ruijie(config-vpdn)# <b>source-ip</b> <i>src-ip</i> | VPDN-group |
| Ruijie(config-vpdn)# <b>no source-ip</b>            | VPDN-group |

*src-ip* VPDN-group

#### 41.3.6.8 L2TP

L2TP

|  |       |
|--|-------|
|  |       |
| Ruijie(config-vpdn)# <b>l2tp tunnel authentication</b>                 |       |
| Ruijie(config-vpdn)# <b>no l2tp tunnel authentication</b>              |       |
| Ruijie(config-vpdn)# <b>l2tp tunnel hello interval</b> <i>interval</i> | Hello |
| Ruijie(config-vpdn)# <b>no l2tp tunnel hello</b>                       | Hello |
| Ruijie(config-vpdn)# <b>l2tp tunnel password</b> <i>pass-word</i>      |       |
| Ruijie(config-vpdn)# <b>no l2tp tunnel password</b>                    |       |
| Ruijie(config-vpdn)# <b>l2tp tunnel receive-window</b> <i>size</i>     |       |
| Ruijie(config-vpdn)# <b>no l2tp tunnel receive-window</b>              |       |

|   |   |
|---|---|
| <pre> R1(config-vpdn)# retransmit {retries <i>number</i> timeout {min   max} <i>seconds</i>} </pre> |   |
| <pre> R1(config-vpdn)# retransmit {retries   timeout {min max}} </pre>                              |   |
| <pre> R1(config-vpdn)# {no-session   setup} <i>seconds</i> </pre>                                   | / |
| <pre> R1(config-vpdn)# timeout {no-session   setup} </pre>  | / |

```

L2TP ( Cisco )
Hello 5 60 1 4
8 600

```

### 41.3.7

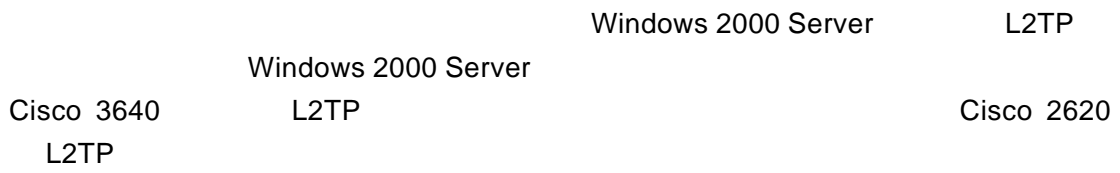

#### 41.3.7.1 Windows 2000

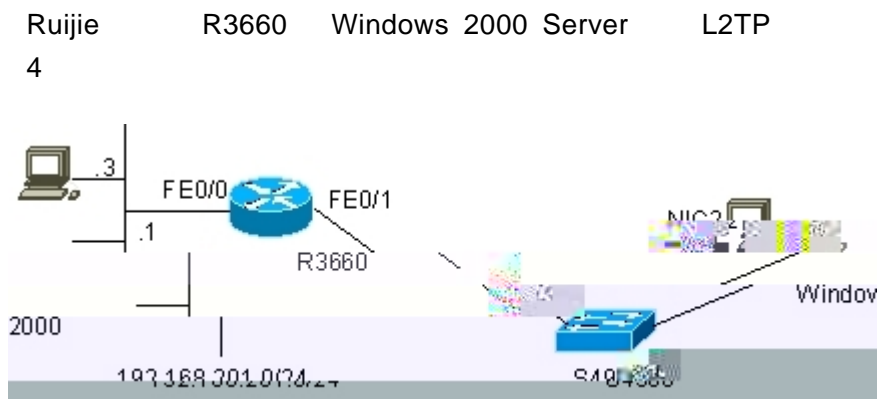

4 Windows 2000(LAC) L2TP

R3660 Windows 2000 Server

1)R3660

```
R3660# show running-config
Building configuration...
Current configuration : 760 bytes
defnL2TPVTP(rco)6up.
p. v0
```

```
!  
ip local pool vpdnusers 192.168.101.3 192.168.101.253  
!
```

```
2.5525EJ0.017 T o n l i n e s i d e ( 1 6 8 . 1 0 1 . 3 1 6 4 3 1 9 5 0 ) i 9 . 0 2 8 0 T o 1 7 0 s 2 6 5 8 r t w @ t h e r e c a s d r e s s 2 . 1 6 8 . 1 0 1
```



## 1)R3660

```
R3660# show ip route
```

```
Codes: C - connected, S - static, R - RIP
```

```
O - OSPF, IA - OSPF inter area
```

```
E1 - OSPF external type 1, E2 - OSPF external type 2
```

```
Gateway of last resort is not set
```

```
192.168.101.0/24 is variably subnetted, 2 subnets, 2 masks
```

```
C      192.168.101.8/32 is directly connected, Virtual-Access1
```

```
C      192.168.101.0/24 is directly connected, Loopback1
```

```
C     192.168.12.0/24 is directly connected, GigabitEthernet0/1
```

```
C     192.168.201.0/24 is directly connected, GigabitEthernet0/0
```

```
R3660#ping 192.168.101.8
```

```
Type escape sequence to abort.
```

```
Sending 5, 100-byte ICMP Echoes to 192.168.101.8, timeout is 2 seconds:
```

```
!!!!!
```

```
Success rate is 100 percent (5/5), round-trip min/avg/max = 1/2/4 ms
```

```
R3660#show vpdn tunnel
```

```
L2TP Tunnel Information Total tunnels 1
```

```
LocID RemID Remote Name   State Remote Address  Port  Sessions L2TP
Class/
```

```
VPDN Group
```

```
7     8     BLIZZARD     est   192.168.12.213  1701  1         1
```

```
%No active PPTP tunnels
```

```
R3660#
```

```
R3660# show vpdn session
```

```
L2TP Session Information Total sessions 1
```

```
LocID   RemID   TunID   Username, Intf/   State
```

```
Last Chg
```

```
Vcid, Circuit
```

```
1       1       7       ,Vil             est   00:02:08
```

```
%No active PPTP tunnels
```

```
R3660#
```

## 2).Windows 2000:

```
Microsoft Windows 2000 [Version 5.00.2195]
```

```
(C)          1985-2000 Microsoft Corp.
```

```
C:\>ipconfig /all
```

```
Windows 2000 IP Configuration
```

```
Host Name . . . . . : BLIZZARD
```

```
Primary DNS Suffix . . . . . :
```

---

```
Node Type . . . . . : Broadcast
IP Routing Enabled. . . . . : No
WINS Proxy Enabled. . . . . : No

Ethernet adapter 2:
Connection-specific DNS Suffix . :
Description . . . . . : NE2000 Compatible
Physical Address. . . . . : 00-10-88-01-A5-C3
DHCP Enabled. . . . . : No
IP Address. . . . . : 192.168.12.213
Subnet Mask . . . . . : 255.255.255.0
Default Gateway . . . . . : 192.168.12.1
DNS Servers . . . . . : 202.101.143.141
PPP adapter L2TP:
Connection-specific DNS Suffix . :
Description . . . . . : WAN (PPP/SLIP) Interface
Physical Address. . . . . : 00-53-45-00-00-00
DHCP Enabled. . . . . : No
IP Address. . . . . : 192.168.101.8
Subnet Mask . . . . . : 255.255.255.255
Default Gateway . . . . . : 192.168.101.8
DNS Servers . . . . . :
C:\>route print

=====
Interface List
0x1 . . . . . MS TCP Loopback interface
0x2000003 . . . . . 00 10 88 01 a5 c3 . . . . . Novell 2000 Adapter.
0xd000004 . . . . . 00 53 45 00 00 00 . . . . . WAN (PPP/SLIP) Interface
=====
=====
Active Routes:
Network Destination        Netmask          Gateway          Interface
Metric
0.0.0.0      0.0.0.0      192.168.12.1  192.168.12.213    2
```

```
192.168.12.255 255.255.255.255 192.168.12.213 192.168.12.213
1
192.168.101.2 255.255.255.255 192.168.101.8 192.168.101.8
1
192.168.101.8 255.255.255.255 127.0.0.1 127.0.0.1
1
192.168.101.255 255.255.255.255 192.168.101.8 192.168.101.8
1
224.0.0.0 224.0.0.0 192.168.12.213 192.168.12.213 1
224.0.0.0 224.0.0.0 192.168.101.8 192.168.101.8 1
255.255.255.255 255.255.255.255 192.168.12.213 192.168.12.213
1
Default Gateway: 192.168.101.8
```

```
=====
```

```
Persistent Routes:
```

```
None
```

```
C:\>ping 192.168.101.2
```

```
Pinging 192.168.101.2 with 32 bytes of data:
```

```
Reply from 192.168.101.2: bytes=32 time<10ms TTL=255
```

```
Reply from 192.168.101.2: bytes=32 time<10ms TTL=255
```

```
Reply from 192.168.101.2: bytes=32 time<10ms TTL=255
```

```
Reply from 192.168.101.2: bytes=32 time<10ms TTL=255
```

```
Ping statistics for 192.168.101.2:
```

```
Packets: Sent = 4, Received = 4, Lost = 0 (0% loss),
```

```
Approximate round trip times in milli-seconds:
```

```
Minimum = 0ms, Maximum = 0ms, Average = 0ms
```

```
C:\>ping 192.168.201.1
```

```
Pinging 192.168.201.1 with 32 bytes of data:
```

```
Reply from 192.168.201.1: bytes=32 time<10ms TTL=255
```

```
Reply from 192.168.201.1: bytes=32 time<10ms TTL=255
```

```
Reply from 192.168.201.1: bytes=32 time<10ms TTL=255
```

```
Reply from 192.168.201.1: bytes=32 time<10ms TTL=255
```

```
Ping statistics for 192.168.201.1:
```

```
Packets: Sent = 4, Received = 4, Lost = 0 (0% loss),
```

```
Approximate round trip times in milli-seconds:
```

```
Minimum = 0ms, Maximum = 0ms, Average = 0ms
```

```
C:\>ping 192.168.201.3
```

```
Pinging 192.168.201.3 with 32 bytes of data:
```

```
Reply from 192.168.201.3: bytes=32 time<10ms TTL=254
```

```
Reply from 192.168.201.3: bytes=32 time<10ms TTL=254
```

```
Reply from 192.168.201.3: bytes=32 time<10ms TTL=254
```

```
Reply from 192.168.201.3: bytes=32 time<10ms TTL=254
```

```

Ping statistics for 192.168.201.3:
Packets: Sent = 4, Received = 4, Lost = 0 (0% loss),
Approximate round trip times in milli-seconds:
Minimum = 0ms, Maximum = 0ms, Average = 0ms
C:\>ping 192.168.12.1
Pinging 192.168.12.1 with 32 bytes of data:
Reply from 192.168.12.1: bytes=32 time=10ms TTL=255
Reply from 192.168.12.1: bytes=32 time<10ms TTL=255
Reply from 192.168.12.1: bytes=32 time<10ms TTL=255
Reply from 192.168.12.1: bytes=32 time<10ms TTL=255
Ping statistics for 192.168.12.1:
Packets: Sent = 4, Received = 4, Lost = 0 (0% loss),
Approximate round trip times in milli-seconds:
Minimum = 0ms, Maximum = 10ms, Average = 2ms
C:\>

```

#### 41.3.7.2 Cisco 3640

Ruijie R3660 Cisco 3640 L2TP  
5



5 Cisco 3640(LAC) L2TP

R3660 Cisco 3640

1)R3660

```

R3660# show running-config
Building configuration...
Current configuration : 766 bytes
!
hostname R3660
!
vpdn enable
!
vpdn-group 1

```

```
! Default L2TP VPDN group
accept-dialin
protocol l2tp
virtual-template 1
l2tp tunnel authentication
l2tp tunnel password share
!
!
!
username rgno$ password 7 025144391715
!
ip local pool vpdnusers 192.168.101.3 192.168.101.253
!
interface GigabitEthernet 0/0
ip address 192.168.201.1 255.255.255.0
duplex auto
speed auto
!
interface GigabitEthernet 0/1
ip address 192.168.12.217 255.255.255.0
duplex auto
speed auto
!
interface Loopback 1
ip address 192.168.101.2 255.255.255.0
!
interface Null 0
!
interface Virtual-Template 1
ppp authentication pap
ip unnumbered Loopback 1
peer default ip address loopback 1
```



```
speed auto
duplex auto
!
interface GigabitEthernet2/1
ip address 192.168.203.1 255.255.255.0
duplex auto
speed auto
!
interface Serial3/0:1
ip address 192.168.1.2 255.255.255.0
!
interface Virtual-PPP1
ip address negotiated
no cdp enable
ppp pap sent-username rgnos password 0 rgnos
pseudowire 192.168.12.217 11 pw-class pw
!
no ip http server
ip classless
ip route 0.0.0.0 0.0.0.0 GigabitEthernet2/0 192.168.12.1
!
!
dial-peer cor custom
!
dial-peer voice 111 voip
session protocol sipv2
codec g711alaw
!
!
line con 0
exec-timeout 0 0
line aux 0
line vty 0 4
privilege level 15
no login
line vty 5 871
login
!
!
end
```

L2TP

## 1)R3660

R3660# **show ip route**

Codes: C - connected, S - static, R - RIP

O - OSPF, IA - OSPF inter area

E1 - OSPF external type 1, E2 - OSPF external type 2

Gateway of last resort is not set

192.168.101.0/24 is variably subnetted, 2 subnets, 2 masks

C 192.168.101.9/32 is directly connected, Virtual-Access1

C 192.168.101.0/24 is directly connected, Loopback1

C 192.168.12.0/24 is directly connected, GigabitEthernet0/1

C 192.168.201.0/24 is directly connected, GigabitEthernet0/0

R3660# **show vpdn**

L2TP Tunnel and Session Information Total tunnels 1 sessions 1

| LocID | RemID | Remote Name | State | Remote Address | Port | Sessions | L2TP Class/ |
|-------|-------|-------------|-------|----------------|------|----------|-------------|
|-------|-------|-------------|-------|----------------|------|----------|-------------|

VPDN Group

|   |       |       |     |                |      |   |   |
|---|-------|-------|-----|----------------|------|---|---|
| 9 | 21511 | C3640 | est | 192.168.12.242 | 1701 | 1 | 1 |
|---|-------|-------|-----|----------------|------|---|---|

| LocID | RemID | TunID | Username, Intf/<br>Vcid, Circuit | State | Last Chg |
|-------|-------|-------|----------------------------------|-------|----------|
|-------|-------|-------|----------------------------------|-------|----------|

|   |    |   |      |     |          |
|---|----|---|------|-----|----------|
| 1 | 14 | 9 | ,Vil | est | 00:18:06 |
|---|----|---|------|-----|----------|

%No active PPTP tunnels

R3660#ping 192.168.101.9

Type escape sequence to abort.

Sending 5, 100-byte ICMP Echoes to 192.168.101.9, timeout is 2 seconds:

!!!!

Success rate is 100 percent (5/5), round-trip min/avg/max = 1/2/4 ms

R3660#

## L2TP

## 2)Cisco 3640

C3640# **show ip route**

Codes: C - connected, S - static, R - RIP, M - mobile, B - BGP

D - EIGRP, EX - EIGRP external, O - OSPF, IA - OSPF inter area

N1 - OSPF NSSA external type 1, N2 - OSPF NSSA external type 2

E1 - OSPF external type 1, E2 - OSPF external type 2

i - IS-IS, su - IS-IS summary, L1 - IS-IS level-1, L2 - IS-IS level-2

ia - IS-IS inter area, \* - candidate default, U - per-user static route

o - ODR, P - periodic downloaded typen Remote

C 192.161192 conti ga(ot)Eth pont1920/0

```
C      132.11.10.0 is directly connected, Loopback0
C      192.168.1.0/24 is directly connected, Serial3/0:1
192.168.101.0/32 is subnetted, 2 subnets
C      192.168.101.9 is directly connected, Virtual-PPP1
```



## 6 Cisco 2620(LAC) L2TP

R3660 Cisco 2620

### 1)R3660

```
R3660# show running-config
Building configuration...
Current configuration : 989 bytes
!
hostname R3660
!
vpdn enable
!
vpdn-group 1
! Default L2TP VPDN group
accept-dialin
protocol l2tp
virtual-template 1
l2tp tunnel authentication
l2tp tunnel password share
!
!
!
username rgnos password 7 025144391715
username pc@i-net.com.cn password 7 127654431B
!
ip local pool vpdnusers 192.168.101.3 192.168.101.253
!
interface serial 1/0
encapsulation PPP
ip address 202.101.93.21 255.255.255.0
!
interface serial 1/1
clock rate 64000
```

```
!  
interface serial 1/2  
clock rate 64000  
!  
interface serial 1/3  
clock rate 64000  
!  
interface GigabitEthernet 0/0  
duplex auto  
speed auto  
!  
interface GigabitEthernet 0/1  
ip address 192.168.19.1 255.255.255.0  
duplex auto  
speed auto  
!  
interface Loopback 1  
ip address 192.168.101.2 255.255.255.0  
!  
interface Null 0  
!  
interface Virtual-Template 1  
ppp authentication pap  
ip unnumbered Loopback 1  
peer default ip address pool vpdnusers  
!  
!  
line con 0  
line aux 0  
line vty 0 4  
!  
!  
end  
R3660#
```

## 2)Cisco2620

```
Cisco2620# show running-config  
Building configuration...  
Current configuration : 1677 bytes  
!  
version 12.3  
service timestamps debug uptime
```

```
service timestamps log uptime
no service password-encryption
no service dhcp
!
hostname Cisco2620
!
!
username pc password 0 1111
username 163 password 0 163
no aaa new-model
ip subnet-zero
!
!
!
vpdn enable
!
vpdn-group 1
request-dialin
protocol l2tp
domain i-net.com.cn
initiate-to ip 202.101.93.21
l2tp tunnel password 7 0832444F1B1C
!
interface GigabitEthernet0/0
ip address 192.168.7.1 255.255.255.0
duplex auto
speed 10
!
interface Serial0/0
ip address 202.101.93.23 255.255.255.0
encapsulation ppp
fair-queue
clockrate 2000000
!
interface Serial0/1
no ip address
shutdown
!
interface Async65
ip address 5.5.5.5 255.255.255.0
encapsulation ppp
dialer in-band
```

```
dialer idle-timeout 30000
dialer string 8435
dialer-group 1
async mode dedicated
peer default ip address 5.5.5.6
ppp authentication pap
!
no ip http server
ip classless
!
dialer-list 1 protocol ip permit
!
!
line con 0
exec-timeout 0 0
line aux 0
login local
modem InOut
transport input all
autoselect during-login
autoselect ppp
line vty 0 4
privilege level 15
no login
line vty 5 15
login
!
no scheduler allocate
end
Cisco2620#
```

|             |                   |        |      |
|-------------|-------------------|--------|------|
| Mobile User | "pc@i-net.com.cn" | "1111" | L2TP |
| R3660       | 192.168.19.0/24   |        |      |

---

| Ruijie# <b>show vpdn [tunnel session]</b><br>Ruijie> <b>show vpdn [tunnel session]</b>                            | vpdn        |
|---|-------------|
| Ruijie# <b>debug vpdn error</b>   | vpdn error  |
| Ruijie# <b>no debug vpdn error</b>  | vpdn error  |
| Ruijie# <b>debug vpdn event</b><br><del>Ruijie&gt; Tj/TT39 Tf0.0209 Tc 0.0041 Tw 3.2 0 Tdl2x Tw 0 spdn erro</del> | vpdn event  |
| Ruijie# <b>no debug vpdn event</b>  | vpdn event  |
| Ruijie# <b>debug vpdn packet</b>  | vpdn packet |

```

%No active PPTP tunnels
Ruijie# show vpdn
L2TP Tunnel and Session Information Total tunnels 1 sessions 1
LocID RemID Remote Name State Remote Address Port Sessions L2TP
Class/
                                         VPDN Group
1      35390 C3640          est   192.168.12.242 1701 1      1
LocID      RemID      TunID      Username, Intf/      State Last Chg
                                         Vcid, Circuit
1          1261      1          rgnos,Vil          est
01:04:45
%No active PPTP tunnels
Ruijie#

```

#### 41.4.1.2 VPDN

```

          VPDN          L2TP          PPTP
LNS      (              ) VPDN

Ruijie# debug vpdn error
vpdn protocol errors debugging is on
Ruijie# debug vpdn event
vpdn events debugging is on
Ruijie# debug vpdn packet
vpdn packet debugging is on
Ruijie# show debug
VPDN:
vpdn events debugging is on
vpdn protocol errors debugging is on
vpdn packet debugging is on
Ruijie#
VPDN PROCESS From tunnel: Received 158 byte pak
L2X: UDP socket write 168 bytes, 192.168.12.217(1701) to
192.168.12.242(1701)
L2X: UDP socket write 40 bytes, 192.168.12.217(1701) to
192.168.12.242(1701)
VPDN PROCESS From tunnel: Pak consumed
VPDN PROCESS From tunnel: Received 70 byte pak
L2X: UDP socket write 40 bytes, 192.168.12.217(1701) to
192.168.12.242(1701)
VPDN PROCESS From tunnel: Pak consumed
VPDN PROCESS From tunnel: Received 76 byte pak

```

```
Get virtual-access from free queue: Virtual-Access1
Clone virtual-access from interface Virtual-Templatel
L2X: UDP socket write 56 bytes, 192.168.12.217(1701) to
192.168.12.242(1701)
L2X: UDP socket write 40 bytes, 192.168.12.217(1701) to
192.168.12.242(1701)
VPDN PROCESS From tunnel: Pak consumed
VPDN PROCESS From tunnel: Received 76 byte pak
L2X: UDP socket write 40 bytes, 192.168.12.217(1701) to
192.168.12.242(1701)
Vi1 Tnl/Sn 3/1 L2TP: Virtual interface created for unknown, bandwidth
1024 Kbps
Vi1 Tnl/Sn 3/1 L2TP: VPDN session up
VPDN PROCESS From tunnel: Pak consumed
VPDN PROCESS From tunnel: Received 50 byte pak
Vi1 VPDN PROCESS From tunnel: Queue 14 byte pak to ppp parse and iqueue
Vi1 VPDN PROCESS From tunnel: Pak send successful
%UPDOWN: Interface Virtual-Access1, changed state to up
Vi1 VPDN PROCESS Into tunnel: Sending 54 byte pak
L2X: UDP socket write 54 bytes, 255.255.255.255(1701) to
4.83.68.68(1701)
VPDN PROCESS From tunnel: Received 50 byte pak
Vi1 VPDN PROCESS From tunnel: Queue 14 byte pak to ppp parse and iqueue
Vi1 VPDN PROCESS From tunnel: Pak send successful
Vi1 VPDN PROCESS Into tunnel: Sending 50 byte pak
L2X: UDP socket write 50 bytes, 255.255.255.255(1701) to
4.83.68.68(1701)
Vi1 VPDN PROCESS Into tunnel: Sending 54 byte pak
L2X: UDP socket write 54 bytes, 255.255.255.255(1701) to
4.83.68.68(1701)
VPDN PROCESS From tunnel: Received 50 byte pak
Vi1 VPDN PROCESS From tunnel: Queue 14 byte pak to ppp parse and iqueue
Vi1 VPDN PROCESS From tunnel: Pak send successful
Vi1 VPDN PROCESS Into tunnel: Sending 50 byte pak
L2X: UDP socket write 50 bytes, 255.255.255.255(1701) to
4.83.68.68(1701)
Vi1 VPDN PROCESS Into tunnel: Sending 54 byte pak
L2X: UDP socket write 54 bytes, 255.255.255.255(1701) to
4.83.68.68(1701)
VPDN PROCESS From tunnel: Received 50 byte pak
Vi1 VPDN PROCESS From tunnel: Queue 14 byte pak to ppp parse and iqueue
Vi1 VPDN PROCESS From tunnel: Pak send successful
```

```
Vi1 VPDN PROCESS Into tunnel: Sending 50 byte pak
L2X: UDP socket write 50 bytes, 192.168.12.217(1701) to
192.168.12.242(1701)
Vi1 VPDN PROCESS Into tunnel: Sending 54 byte pak
L2X: UDP socket write 54 bytes, 192.168.12.217(1701) to
192.168.12.242(1701)
VPDN PROCESS From tunnel: Received 54 byte pak
Vi1 VPDN PROCESS From tunnel: Queue 18 byte pak to ppp parse and iqueue
Vi1 VPDN PROCESS From tunnel: Pak send successful
VPDN PROCESS From tunnel: Received 56 byte pak
Vi1 VPDN PROCESS From tunnel: Queue 20 byte pak to ppp parse and iqueue
Vi1 VPDN PROCESS From tunnel: Pak send successful
Vi1 VPDN PROCESS Into tunnel: Sending 45 byte pak
L2X: UDP socket write 45 bytes, 192.168.12.217(1701) to
192.168.12.242(1701)
Vi1 VPDN PROCESS Into tunnel: Sending 50 byte pak
L2X: UDP socket write 50 bytes, 192.168.12.217(1701) to
192.168.12.242(1701)
VPDN PROCESS From tunnel: Received 50 byte pak
Vi1 VPDN PROCESS From tunnel: Queue 14 byte pak to ppp parse and iqueue
Vi1 VPDN PROCESS From tunnel: Pak send successful
Vi1 VPDN PROCESS Into tunnel: Sending 50 byte pak
L2X: UDP socket write 50 bytes, 192.168.12.217(1701) to
192.168.12.242(1701)
VPDN PROCESS From tunnel: Received 50 byte pak
Vi1 VPDN PROCESS From tunnel: Queue 14 byte pak to ppp parse and iqueue
Vi1 VPDN PROCESS From tunnel: Pak send successful
VPDN PROCESS From tunnel: Received 50 byte pak
Vi1 VPDN PROCESS From tunnel: Queue 14 byte pak to ppp parse and iqueue
Vi1 VPDN PROCESS From tunnel: Pak send successful
Vi1 VPDN PROCESS Into tunnel: Sending 50 byte pak
L2X: UDP socket write 50 bytes, 192.168.12.217(1701) to
192.168.12.242(1701)
%UPDOWN: Line protocol on Interface Virtual-Access1, changed state
to up
Ruijie# show ip route
```

```
C    192.168.101.0/24 is directly connected, Virtual-Access1
C    192.168.12.0/24 is directly connected, GigabitEthernet0
C    192.168.201.0/24 is directly connected, Ethernet0
Ruijie#
```

#### 41.4.1.3 L2TP

```
                L2TP
                l2x-data
                ) L2TP
                LNS
                L2TP
                (

Ruijie# no debug all
All possible debugging has been turned off
Ruijie# debug vpdn l2x-data
L2X data packets debugging is on
Ruijie#
L2X: Punting to L2TP control message queue
L2X: Punting to L2TP control message queue
L2X: Punting to L2TP control message queue
L2X: Punting to L2TP control message queue
L2X: Punting to L2TP control message queue
L2X: Punting to L2TP control message queue
%UPDOWN: Interface Virtual-Access1, changed state to up
%UPDOWN: Line protocol on Interface Virtual-Access1, changed state
to up
Ruijie#
```

#### 41.4.1.4 L2TP

```
                l2x-errors
                )
                (

Ruijie# no debug all
All possible debugging has been turned off
Ruijie# debug vpdn l2x-errors
L2X protocol errors debugging is on
Ruijie# config terminal
Enter configuration commands, one per line.  End with CNTL/Z.
Ruijie(config)# interface virtual-ppp 1
Ruijie(config-ppp)#
```

```
Tnl 14 L2TP: Tunnel auth failed for BLIZZARD
Tnl 14 L2TP: Expected
9E 8D 7A 8E 78 EA 41 9F A1 74 01 21 DE 4F F3 F0
Tnl 14 L2TP: Got
84 E5 62 69 AE 46 A5 98 4E FE E2 38 EE F2 B7 E2
Ruijie# no debug all
All possible debugging has been turned off
Ruijie#
```

#### 41.4.1.5 L2TP

```
                l2x-events                L2TP
                l2x-events                LNS                (
                )
```

```
Ruijie# show vpdn tunnel
%No active L2TP tunnels
%No active PPTP tunnels
Ruijie# no debug all
All possible debugging has been turned off
Ruijie# debug vpdn l2x-events
```

```

ection-iccn
Vil Tnl/Sn 20/1 L2TP: Session state change from
wait-for-service-selection- iccn to established
%UPDOWN: Interface Virtual-Access1, changed state to up
%UPDOWN: Line protocol on Interface Virtual-Access1, changed state
to up
Ruijie# show ip route
Codes: C - connected, S - static, R - RIP
O - OSPF, IA - OSPF inter area
E1 - OSPF external type 1, E2 - OSPF external type 2
Gateway of last resort is not set
192.168.101.0/24 is variably subnetted, 2 subnets, 2 masks
C      192.168.101.7/32 is directly connected, Virtual-Access1
C      192.168.101.0/24 is directly connected, Virtual-Access1
C     192.168.12.0/24 is directly connected, GigabitEthernet0
C     192.168.201.0/24 is directly connected, Ethernet0
Ruijie# show vpdn
L2TP Tunnel and Session Information Total tunnels 1 sessions 1
LocID RemID Remote Name  State  Remote Address  Port  Sessions L2TP
Class/
                                         VPDN Group
20    26656 C3640      est   192.168.12.242  1701  1      1
LocID  RemID  TunID  Username, Intf/  State  Last Chg
          Vcid, Circuit
1     1279    20    rgnos,Vil      est   00:00:38
%No active PPTP tunnels
Ruijie#
                l2x-evetns                LAC                L2TP Server
                (                )

Ruijie# no debug all

```

```

Tnl 21 L2TP: Control channel retransmit delay set to 1 seconds
Tnl 21 L2TP: Tunnel state change from idle to wait-ctl-reply
Tnl 21 L2TP: SM State wait-ctl-reply
Tnl 21 L2TP: O Resend SCCRQ, flg TLS, ver 2, len 96, tnl 0, ns 0, nr
0
Tnl 21 L2TP: Control channel retransmit delay set to 1 seconds
Tnl 21 L2TP: I SCCRP from
Tnl 21 L2TP: O SCCCN to BLIZZARD tnlid 40
Tnl 21 L2TP: Control channel retransmit delay set to 1 seconds
Tnl 21 L2TP: Tunnel state change from wait-ctl-reply to established
Tnl 21 L2TP: SM State established
Vil Tnl/Sn 21/1 L2TP: O ICRQ to BLIZZARD 40/0
Vil Tnl/Sn 21/1 L2TP: Control channel retransmit delay set to 1 seconds
Vil Tnl/Sn 21/1 L2TP: Session state change from wait-for-tunnel to
wait-reply
Vil Tnl/Sn 21/1 L2TP: I ICRP from BLIZZARD
Vil Tnl/Sn 21/1 L2TP: O ICCN to BLIZZARD 40/1
Vil Tnl/Sn 21/1 L2TP: Control channel retransmit delay set to 1 seconds
Vil Tnl/Sn 21/1 L2TP: Session state change from wait-reply to
established
%UPDOWN: Interface Virtual-PPP1, changed state to up
%UPDOWN: Line protocol on Interface Virtual-PPP1, changed state to
up
Ruijie# show vpdn
L2TP Tunnel and Session Information Total tunnels 1 sessions 1
LocID RemID Remote Name State Remote Address Port Sessions L2TP
Class/
                                         VPDN Group
21 40 BLIZZARD est 192.168.12.213 1701 1
LocID RemID TunID Username, Intf/ State Last Chg
Vcid, Circuit
1 1 21 13,Vil est 00:00:27
%No active PPTP tunnels
Ruijie#

```

#### 41.4.1.6 L2TP

```

L2TP                               I2x-packets           L2TP
                                I2x-packets           LNS
                                (           )
Ruijie# no debug all

```

```
All possible debugging has been turned off
Ruijie# debug vpdn l2x-packets
L2X control packets debugging is on
Ruijie# show vpdn
%No active L2TP tunnels
%No active PPTP tunnels
Ruijie#
L2TP: I SCCRQ from C3640 tnl 18889
L2X: Parse AVP 0, len 8, flag 0x8000 (M)
L2X: Parse SCCRQ
L2X: Parse AVP 2, len 8, flag 0x8000 (M)
L2X: Protocol Ver 1
L2X: Parse AVP 6, len 8, flag 0x0
L2X: Firmware Ver 0x1130
L2X: Parse AVP 7, len 11, flag 0x8000 (M)
L2X: Hostname C3640
L2X: Parse AVP 8, len 25, flag 0x0
L2X: Vendor Name Cisco Systems, Inc.
L2X: Parse AVP 10, len 8, flag 0x8000 (M)
L2X: Rx Window Size 800
L2X: Parse AVP 11, len 22, flag 0x8000 (M)
L2X: Chlng
          98 20 4E 34 6A 4C E1 E7 FA CF 58 07 FF 4E 56 A3
L2X: Parse AVP 9, len 8, flag 0x8000 (M)
L2X: Assigned Tunnel ID 18889
L2X: Parse AVP 3, len 10, flag 0x8000 (M)
L2X: Framing Cap 0x3
L2X: Parse AVP 4, len 10, flag 0x8000 (M)
L2X: Bearer Cap 0x3
L2X: No missing AVPs in SCCRQ
L2X: I SCCRQ, flg TLS, ver 2, len 130, tnl 0, ns 0, nr 0 contiguous
pak, size 130
C8 02 00 82 00 00 00 00 00 00 00 80 08 00 00
00 00 00 01 80 08 00 00 00 02 01 00 00 08 00 00
00 06 11 30 80 0B 00 00 00 07 43 33 36 34 30 00
19 00 00 00 08 43 69 73 63 6F 20 53 79 73 74 65
6D 73 2C 20 49 6E 63 2E ...

Tnl 22 L2TP: O SCCRQ to C3640 tnlid 18889
Tnl 22 L2TP: O SCCRQ, flg TLS, ver 2, len 140, tnl 18889, ns 0, nr
1
C8 02 00 8C 49 C9 00 00 00 00 01 80 08 00 00
00 00 00 02 80 08 00 00 00 02 01 00 80 0A 00 00
```

```
00 03 00 00 00 01 80 0A 00 00 00 04 00 00 00 00
00 08 00 00 00 06 11 30 80 0A 00 00 00 07 52 36
32 31 00 0E 00 00 00 08 ...

Tnl 22 L2TP: O ZLB ctrl ack, flg TLS, ver 2, len 12, tnl 18889, ns
1, nr 1
C8 02 00 0C 49 C9 00 00 00 01 00 01
Tnl 22 L2TP: Parse AVP 0, len 8, flag 0x8000 (M)
Tnl 22 L2TP: Parse SCCCN
Tnl 22 L2TP: I SCCCN from C3640 tnl 18889
Tnl 22 L2TP: Parse AVP 13, len 22, flag 0x8000 (M)
Tnl 22 L2TP: Chlng Resp
5C D5 A4 37 36 A6 7D 0F FE EF 22 48 B8 DF F5 12
Tnl 22 L2TP: No missing AVPs in SCCCN
Tnl 22 L2TP: I SCCCN, flg TLS, ver 2, len 42, tnl 22, ns 1, nr 1 contiguous
pak, size 42
C8 02 00 2A 00 16 00 00 00 01 00 01 80 08 00 00
00 00 00 03 80 16 00 00 00 0D 5C D5 A4 37 36 A6
7D 0F FE EF 22 48 B8 DF F5 12
Tnl 22 L2TP: O ZLB ctrl ack, flg TLS, ver 2, len 12, tnl 18889, ns
1, nr 2
C8 02 00 0C 49 C9 00 00 00 01 00 02
Tnl 22 L2TP: Parse AVP 0, len 8, flag 0x8000 (M)
Tnl 22 L2TP: Parse ICRQ
Tnl 22 L2TP: I ICRQ from C3640 tnl 18889
Tnl 22 L2TP: Parse AVP 15, len 10, flag 0x8000 (M)
Tnl 22 L2TP: Serial Number -1714567290
Tnl 22 L2TP: Parse AVP 14, len 8, flag 0x8000 (M)
Tnl 22 L2TP: Assigned Call ID 1280
Tnl 22 L2TP: Parse AVP 18, len 10, flag 0x8000 (M)
Tnl 22 L2TP: Bearer Type 0
Tnl 22 L2TP: No missing AVPs in ICRQ
Tnl 22 L2TP: I ICRQ, flg TLS, ver 2, len 48, tnl 22, ns 2, nr 1 contiguous
pak, size 48
C8 02 00 30 00 16 00 00 00 02 00 01 80 08 00 00
00 00 00 0A 80 0A 00 00 00 0F 99 CD C7 86 80 08
00 00 00 0E 05 00 80 0A 00 00 00 12 00 00 00 00
Tnl/Sn 22/1 L2TP: O ICRP to C3640 18889/1280
Tnl/Sn 22/1 L2TP: O ICRP, flg TLS, ver 2, len 28, tnl 18889, lsid 1,
rsid 1280, ns 1, nr 3
C8 02 00 1C 49 C9 05 00 00 01 00 03 80 08 00 00
00 00 00 0B 80 08 00 00 00 0E 00 01
```



```
Ruijie#  
  
                l2x-packets                LAC                L2TP Server  
                (                )  
  
Ruijie# no debug all  
All possible debugging has been turned off  
Ruijie# debug vpdn l2x-packets  
L2X control packets debugging is on  
Ruijie# config terminal  
Enter configuration commands, one per line. End with CNTL/Z.  
Ruijie(config)# interface virtual-ppp 1  
Ruijie(config-if)# no shutdown  
Ruijie(config-if)# end  
Ruijie#  
Tnl 21 L2TP: O SCCRQ  
Tnl 21 L2TP: O SCCRQ, flg TLS, ver 2, len 96, tnl 0, ns 0, nr 0  
C8 02 00 60 00 00 00 00 00 00 00 00 80 08 00 00  
00 00 00 01 80 08 00 00 00 02 01 00 80 0A 00 00  
00 03 00 00 00 01 80 0A 00 00 00 04 00 00 00 00  
00 08 00 00 00 06 11 30 80 0A 00 00 00 07 52 36  
32 31 00 0E 00 00 00 08 ...  
Tnl 21 L2TP: Parse AVP 0, len 8, flag 0x8000 (M)  
Tnl 21 L2TP: Parse SCCRQ  
Tnl 21 L2TP: Parse AVP 2, len 8, flag 0x8000 (M)  
Tnl 21 L2TP: Protocol Ver 1  
Tnl 21 L2TP: Parse AVP 3, len 10, flag 0x8000 (M)  
Tnl 21 L2TP: Framing Cap 0x1  
Tnl 21 L2TP: Parse AVP 4, len 10, flag 0x8000 (M)  
Tnl 21 L2TP: Bearer Cap 0x0  
Tnl 21 L2TP: Parse AVP 6, len 8, flag 0x0  
Tnl 21 L2TP: Firmware Ver 0x500  
Tnl 21 L2TP: Parse AVP 7, len 14, flag 0x8000 (M)  
Tnl 21 L2TP: Hostname BLIZZARD  
Tnl 21 L2TP: Parse AVP 8, len 15, flag 0x0  
Tnl 21 L2TP: Vendor Name Microsoft  
Tnl 21 L2TP: Parse AVP 9, len 8, flag 0x8000 (M)  
Tnl 21 L2TP: Assigned Tunnel ID 41  
Tnl 21 L2TP: Parse AVP 10, len 8, flag 0x8000 (M)  
Tnl 21 L2TP: Rx Window Size 8  
Tnl 21 L2TP: No missing AVPs in SCCRQ  
Tnl 21 L2TP: I SCCRQ, flg TLS, ver 2, len 101, tnl 21, ns 0, nr 1  
contiguous pak, size 101
```

---

```
C8 02 00 65 00 15 00 00 00 00 01 80 08 00 00
00 00 00 02 80 08 00 00 00 02 01 00 80 0A 00 00
00 03 00 00 00 01 80 0A 00 00 00 04 00 00 00 00
00 08 00 00 00 06 05 00 80 0E 00 00 00 07 42 4C
49 5A 5A 41 52 44 00 0F ...
Tnl 21 L2TP: O SCCCN to BLIZZARD tnlid 41
Tnl 21 L2TP: O SCCCN, flg TLS, ver 2, len 20, tnl 41, ns 1, nr 1
C8 02 00 14 00 29 00 00 00 01 00 01 80 08 00 00
00 00 00 03
Vil Tnl/Sn 21/1 L2TP: O ICRQ to BLIZZARD 41/1
Vil Tnl/Sn 21/1 L2TP: O ICRQ, flg TLS, ver 2, len 48, tnl 41, lsid
1, rsid 1, ns 2, nr 1
C8 02 00 30 00 29 00 00 00 02 00 01 80 08 00 00
00 00 00 0A 80 08 00 00 00 0E 00 01 80 0A 00 00
00 0F 00 00 00 00 80 0A 00 00 00 12 00 00 00 02
Tnl 21 L2TP: O ZLB ctrl ack, flg TLS, ver 2, len 12, tnl 41, ns 3,
nr 1
C8 02 00 0C 00 29 00 00 00 03 00 01
Tnl 21 L2TP: I ZLB ctrl ack, flg TLS, ver 2, len 12, tnl 21, ns 1,
nr 2
Tnl 21 L2TP: I ZLB ctrl ack, flg TLS, ver 2, len 12, tnl 21, ns 1,
nr 3
Vil Tnl/Sn 21/1 L2TP: Parse AVP 0, len 8, flag 0x8000 (M)
Vil Tnl/Sn 21/1 L2TP: Parse ICRP
Vil Tnl/Sn 21/1 L2TP: Parse AVP 14, len 8, flag 0x8000 (M)
Vil Tnl/Sn 21/1 L2TP: Assigned Call ID 1
Vil Tnl 21/1 L2TP: No missing AVPs in ICRP
Vil Tnl/Sn 21/1 L2TP: I ICRP, flg TLS, ver 2, len 28, tnl 21, lsid
1, rsid 1, ns 1, nr 3 contiguous pak, size 28
C8 02 00 1C 00 15 00 01 00 01 00 03 80 08 00 00
00 00 00 0B 80 08 00 00 00 0E 00 01
Vil Tnl/Sn 21/1 L2TP: O ICCN to BLIZZARD 41/1
Vil Tnl/Sn 21/1 L2TP: O ICCN, flg TLS, ver 2, len 40, tnl 41, lsid
1, rsid 1, ns 3, nr 2
C8 02 00 28 00 29 00 01 00 03 00 02 80 08 00 00
00 00 00 0C 80 0A 00 00 00 18 00 98 96 80 80 0A
00 00 00 13 00 00 00 01
Tnl 21 L2TP: O ZLB ctrl ack, flg TLS, ver 2, len 12, tnl 41, ns 4,
nr 2
C8 02 00 0C 00 29 00 00 00 04 00 02
Tnl 21 L2TP: I ZLB ctrl ack, flg TLS, ver 2, len 12, tnl 21, ns 2,
nr 4
```

---

```
%UPDOWN: Interface Virtual-PPP1, changed state to up
%UPDOWN: Line protocol on Interface Virtual-PPP1, changed state to
up
Ruijie# show vpdn
L2TP Tunnel and Session Information Total tunnels 1 sessions 1
LocID RemID Remote Name   State  Remote Address  Port  Sessions L2TP
Class/
                                                    VPDN Group
21    41    BLIZZARD    est   192.168.12.213  1701  1
LocID    RemID    TunID    Username, Intf/    State  Last Chg
Vcid, Circuit
1        1        21        13,Vil            est   00:00:13
%No active PPTP tunnels
Ruijie#
```

## 41.4.2 L2TP

### L2TP



```
Ruijie# clear vpdn tunnel [{ pptp | l2tp}
[remote-host-name
```

```

%CHANGED: Interface Virtual-Access1, changed state to
administratively down
Ruijie# show vpdn
%No active L2TP tunnels
%No active PPTP tunnels
Ruijie#
    
```

### 41.4.3

- L2TP

  - Windows L2TP      L2TP      MicroSoft PPTP      Windows 2000 L2TP
    - Windows 2000 L2TP      Windows XP L2TP      IPSec/ IKE
    - Windows 2000/XP      MicroSoft      L2TP
  - Windows L2TP      "      "      "
    - "      ( " Internet (V)"      "
    - "      ( )"      PAP      "
    - "      PAP      CHAP
  - Windows L2TP      "      "      "
    - "      "      (A)"      MS-CHAPv2
    - "      "      CHAP      CHAP
    - "      "      "      "

CHAP

    - Windows L2TP      Windows L2TP
    - "      Ruijie L2TP      Ruijie
  - Cisco L2TP      Cisco IOS
    - Ruijie
  - Cisco L2TP      Ruijie LNS Cisco
    - LAC      L2TP      Cisco2620(LAC)
    - Cisco      ip domain-lookup      ip cef      Cisco
    - PPP
  - L2TP
  - Cisco (IOS 12.2 12.3) Windows 2000
    - L2TP



# 42 AAA

AAA

## 42.1 AAA

AAA Authentication Authorization and Accounting

AAA

AAA

- RADIUS TACACS+ Local

- AAA

- AAA



AAA

---

AAA

AAA

AAA

AAA

- 
- 
- 
-

### 42.1.1 AAA

AAA

### 42.1.2

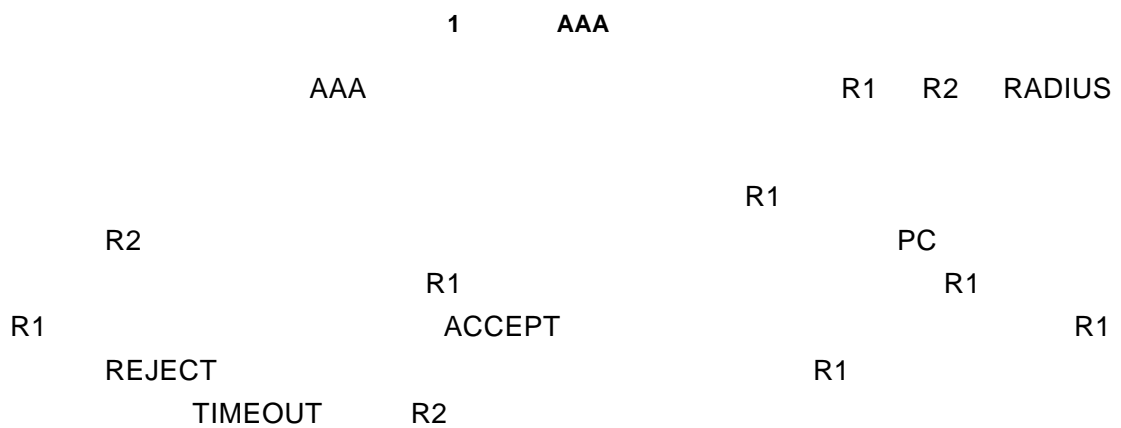

TIMEOUT



REJECT

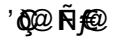

TIMEOUT

REJECT

### 42.2.2 AAA

AAA

AAA

AAA

|                      |     |
|----------------------|-----|
|                      |     |
| <b>aaa new-model</b> | AAA |

### 42.2.3 AAA

### 42.3.1 AAA

AAA



### 42.3.2

AAA

2  
NAS

R1

R2

RADIUS

Telnet

R1

R2

R1 R2





### 42.3.4 AAA

- AAA
  - `aaa new-model` AAA
  - " RADIUS" " TACACS+" RADIUS TACACS+
  - `aaa authentication`
  - DOT1X TACACS+

### 42.3.5 AAA Login

- AAA Login
  - `aaa new-model` AAA AAA
    - " AAA " Telnet (NAS)
  - NAS
  - AAA Login
    - Login
    - `aaa authentication login` Login
  - AAA Login

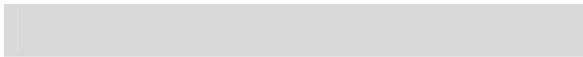

|   |  |
|---|--|
|   |  |
| <b>login authentication</b> {default   <i>list-name</i> } |  |

*list-name*

*method*

ERROR

FAIL( )

**none**

RADIUS )

ifcUDÄpUePŠÖÖqÄW<WpÄ&W2GE+

|                            |  |
|----------------------------|--|
| <b>end</b>                 |  |
| <b>show running-config</b> |  |

## Login

| <b>configure terminal</b>                                   |     |
|---|-----|
| <b>aaa new-model</b>  | AAA |
| <b>aaa authentication login {default   list-name} local</b> |     |
| <b>end</b>  |     |
| <b>show aaa method-list</b>                                 |     |
| <b>configure terminal</b>                                   |     |
| <b>line vty line-num</b>                                    |     |
| <b>login authentication {default   list-name}</b>           |     |
| <b>end</b>  |     |
| <b>show runnuc</b>  |     |

---

|  |        |
|--|--------|
|  |        |
| <b>configure terminal</b>  |        |
| <b>aaa new-model</b>   | AAA    |
| <b>aaa authentication login {default  <br/>list-name} group radius</b> | RADIUS |
| <b>end</b>   |        |
| <b>show aaa method-list</b>  |        |
| <b>configure terminal</b>  |        |

FAIL( )

**none**

Enable

**enable**



CLI

Login

**none**

Enable

Login

CLI

Login

Login

**none**

Enable

Enable

---

Enable

Enable



RADIUS

---

42.3.6.1

Enable

Enable

1

Enable

|   |  |
|---|--|
|   |  |
| <b>configure terminal</b>                                       |  |
| <b>username</b> <i>name</i> [ <b>password</b> <i>password</i> ] |  |

|   |  |
|---|--|
| <b>username</b> <i>name</i> [ <b>privilege</b> <i>level</i> ] |  |
| <b>end</b>  |  |
| <b>show running-config</b>                                    |  |

Enable

PPP

ISDN

NAS

PPP



```
Ruijie(config-line)# end  
Ruijie# show running-config  
!
```



## 42.4.4 AAA Exec

Exec NAS CLI Telnet  
**show privilege**  
 Exec  
**aaa authorization exec**  
 Exec  
 AAA Exec

|  |          |
|--|----------|
| <b>configure terminal</b>  |          |
| <b>aaa new-model</b>   | AAA      |
| <b>aaa authorization exec {default   list-name} method1 [method2...]</b> |          |
| <b>line vty line-num</b>   | AAA Exec |
| <b>authorization exec {default   list-name}</b>                          |          |

*list-name*

*method*

ERROR

FAIL( )

**none**

RADIUS

(TIMEOUT)

Exec

**aaa**

**authorization exec default group radius none**

|                      |              |
|----------------------|--------------|
| <b>local</b>         | Exec         |
| <b>none</b>          | Exec         |
| <b>group radius</b>  | RADIUS Exec  |
| <b>group tacacs+</b> | TACACS+ Exec |

AAA Exec

Exec  
Exec

Login

Login

Login

CLI

Exec

42.4.4.1

Exec

Exec

42.4.4.2          RADIUS          Exec

                  RADIUS                    Exec                    RADIUS                    RADIUS  
  "            RADIUS"

                  RADIUS                    RADIUS

|  |        |
|--|--------|
|  |        |
| <b>configure terminal</b>  |        |
| <b>aaa new-model</b>   | AAA    |
| <b>aaa authorization exec {default   list-name} group radius</b> | RADIUS |
| <b>end</b>   |        |
| <b>show aaa method-list</b>                                      |        |
| <b>configure terminal</b>  |        |
| <b>line vty line-num</b>   |        |
| <b>authorization exec {default   list-name}</b>                  |        |
| <b>end</b>   |        |
| <b>show running-config</b>                                       |        |

42.4.4.3          Exec

                  Exec                    VTY

```

Ruijie(config)# end
Ruijie# show running-config
aaa new-model
!
aaa authorization exec mlist2 group radius local
aaa authentication login mlist1 local
!
username ruijie password ruijie
username ruijie privilege 6
!
radius-server host 192.168.217.64
radius-server key 7 093b100133
!
line con 0
line vty 0 4
  authorization exec mlist2
  login authentication mlist1
!
end

```

## 42.4.5 AAA Network

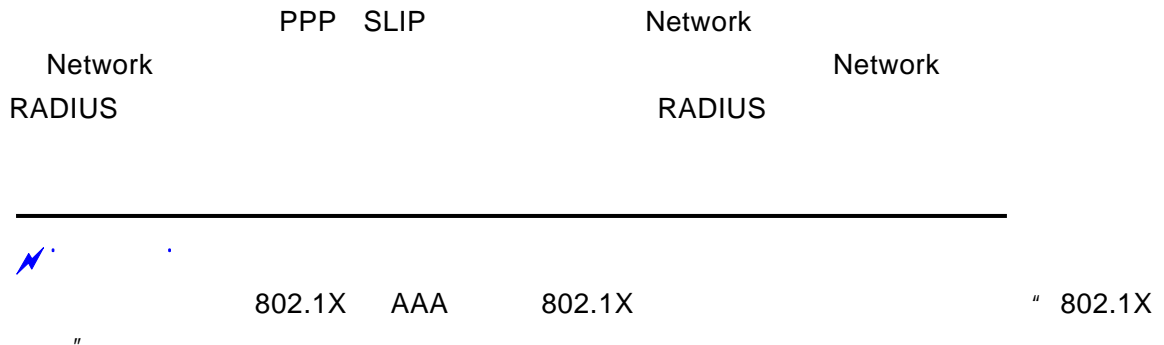

### AAA Network

| <b>configure terminal</b>   |     |
|---|-----|
| <b>aaa new-model</b>  | AAA |
| <b>aaa authorization network {default   list-name} method1 [method2...]</b> |     |

|

|

|

## 42.5

AAA

### 42.5.1

- Exec
- Command
- Network

Exec

NAS

CLI

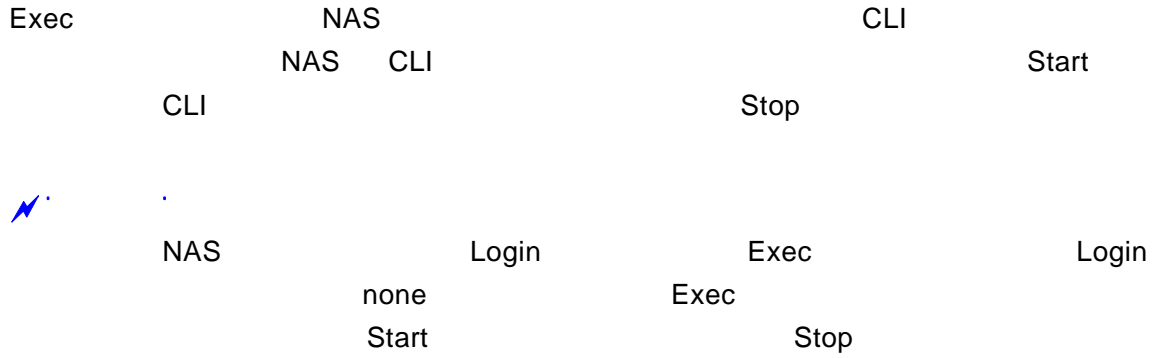

|  |     |
|--|-----|
| AAA Exec   |     |
| <b>configure terminal</b>  |     |
| <b>aaa new-model</b>   | AAA |
| <b>aaa accounting exec</b> {default   list-name}<br><b>start-stop</b> method1 [method2...] |     |

**line vty** line-num

**default** | list-name AAA Exec line-num

RADIUS

RADIUS

| <b>configure terminal</b>             |     |
|---------------------------------------|-----|
| <b>aaa new-model</b>                  | AAA |
| <b>aaa accounting exec {default  </b> |     |

```
aaa authentication login auth local
!
username ruijie password ruijie
!
radius-server host 192.168.217.64
radius-server key 7 093b100133
!
line con 0
line vty 0 4
  accounting exec acct
  login authentication auth
!
end
```

## 42.5.4 AAA Network

|   |         |            |    |
|---|---------|------------|----|
| Network   |         |            | IP |
|   | Network | RADIUS     |    |
|  . |         |            |    |
| RADIUS  |         | RADIUS ?UT |    |

## 42.5.4.1 RADIUS Network

RADIUS Network RADIUS RADIUS  
 " RADIUS"  
 RADIUS RADIUS

| <b>configure terminal</b>   |        |
|---|--------|
| <b>aaa new-model</b>  | AAA    |
| <b>aaa accounting network {default   list-name} start-stop group radius</b> | RADIUS |

## 42.5.4.2 Network

RADIUS Network

```
Ruijie# config
Ruijie(config)# aaa new-model
Ruijie(config)# radius-server host 192.168.217.64
Ruijie(config)# radius-server key test
Ruijie(config)# aaa accounting network acct start-stop group radius
Ruijie(config)# end
Ruijie# show running-config
!
aaa new-model
!
aaa accounting network acct start-stop group radius
!
username Ruijie password 0 starnet
username Ruijie privilege 6
!
radius-server host 192.168.217.64
radius-server key 7 093b100133
```

## 42.6 AAA

|   |     |
|---|-----|
|   |     |
| <code>show aaa user { id   all }</code> | AAA |

## 42.7 VRF AAA

Virtual Private Networks (VPNs)

ISP

VPN

VPN VPN routing/forwarding (VRF) table AAA

VRF

|  |       |
|--|-------|
| <b>aaa local authentication lockout-time</b> <i>num</i>                          | login |
| <b>end</b>   |       |
| <b>show aaa user lockout</b> {all   <b>user-name</b> <i>name-string</i> }        |       |
| <b>clear aaa local user lockout</b> {all   <b>user-name</b> <i>name-string</i> } |       |



Login

3

15

---

# 43 RADIUS

## 43.1 RADIUS

RADIUS (Remote Authentication Dial-In User Service)

/ AAA  
RGOS RADIUS

NAS

RADIUS

RADIUS

UNIX WINDOWS 2000

RADIUS

RADIUS

RADIUS

●

●

● RADIUS

● ACCEPT

RADIUS

●

## 43.2 RADIUS

### RADIUS

- AAA AAA "AAA "
  - **aaa authentication** RADIUS **aaa authentication** " "
  - " "
- RADIUS RADIUS



|    |                      |    |
|----|----------------------|----|
| 19 | flux-max-low32       | 19 |
| 20 | proxy-avoid          | 20 |
| 21 | dailup-avoid         | 21 |
| 22 | ip privilige         | 22 |
| 23 | login privilige      | 42 |
| 24 | limit to user number | 50 |

## ID

| ID |                      | TYPE |
|----|----------------------|------|
| 1  | max down-rate        | 76   |
| 2  | qos                  | 77   |
| 3  | user ip              | 3    |
| 4  | vlan id              | 4    |
| 5  | version to client    | 5    |
| 6  | net ip               | 6    |
| 7  | user name            | 7    |
| 8  | password             | 8    |
| 9  | file-diractory       | 9    |
| 10 | file-count           | 10   |
| 11 | file-name-0          | 11   |
| 12 | file-name-1          | 12   |
| 13 | file-name-2          | 13   |
| 14 | file-name-3          | 14   |
| 15 | file-name-4          | 15   |
| 16 | max up-rate          | 75   |
| 17 | version to server    | 17   |
| 18 | flux-max-high32      | 18   |
| 19 | flux-max-low32       | 19   |
| 20 | proxy-avoid          | 20   |
| 21 | dailup-avoid         | 21   |
| 22 | ip privilige         | 22   |
| 23 | login privilige      | 42   |
| 24 | limit to user number | 50   |



---

```
Ruijie# show radius vendor-specific
```

| id | vendor-specific      | type-value |
|----|----------------------|------------|
| 1  | max down-rate        | 76         |
| 2  | qos                  | 77         |
| 3  | user ip              | 3          |
| 4  | vlan id              | 4          |
| 5  | version to client    | 5          |
| 6  | net ip               | 6          |
| 7  | user name            | 7          |
| 8  | password             | 8          |
| 9  | file-diractory       | 9          |
| 10 | file-count           | 10         |
| 11 | file-name-0          | 11         |
| 12 | file-name-1          | 12         |
| 13 | file-name-2          | 13         |
| 14 | file-name-3          | 14         |
| 15 | file-name-4          | 15         |
| 16 | max up-rate          | 75         |
| 17 | version to server    | 17         |
| 18 | flux-max-high32      | 18         |
| 19 | flux-max-low32       | 19         |
| 20 | proxy-avoid          | 20         |
| 21 | dailup-avoid         | 21         |
| 22 | ip privilige         | 22         |
| 23 | login privilige      | 42         |
| 24 | limit to user number | 50         |

```
Ruijie# configure
```

```
Ruijie(config)# radius attribute 24 vendor-type 67
```

```
Ruijie(config)# show radius vendor-specific
```

| id | vendor-specific | type-value |
|----|-----------------|------------|
| 1  | max down-rate   | 76         |
| 2  | qos             | 77         |

```

3    user ip          3
4    vlan id         4
5    version to client 5
6    net ip          6
7    user name       7
8    password        8
9    file-directory   9
10   file-count      10
11   file-name-0     11
12   file-name-1     12
13   file-name-2     13
14   file-name-3     14
15   file-name-4     15
16   max up-rate     75
17   version to server 17
18   flux-max-high32 18
19   flux-max-low32  19
20   proxy-avoid     20
21   dailup-avoid    21
22   ip privilige    22
23   login privilige 42
24   limit to user number 50
Ruijie(config)#
Ruijie(config)#

```

### 43.3 RADIUS

RADIUS

|                           |                  |
|---------------------------|------------------|
|                           |                  |
| <b>debug radius event</b> | RADIUS<br>RADIUS |

### 43.4 RADIUS

RADIUS

RADIUS



RADIUS                      Windows 2000/2003 Server IAS      UNIX                      ,

---

### RADIUS

```
Ruijie# configure terminal
Ruijie(config)# aaa new-model
Ruijie(config)# radius-server host 192.168.12.219
auth-port 1645 acct-port 1646
Ruijie(config)# radius-server key aaa
Ruijie(config)# aaa authentication login test group radius
Ruijie(config)# end
Ruijie# show radius server
Server IP:            192.168.12.219
Accounting Port:    1646
Authen Port:        1645
Server State:        Ready

Ruijie# configure terminal
Ruijie(config)# line vty 0
Ruijie(config-line)# login authentication test
Ruijie(config-line)# end
Ruijie# show running-config
!
aaa new-model
!
!
aaa authentication login test group radius
!
username ruijie password 0 starnet
!
radius-server host 192.168.12.219 auth-port 1645 acct-port 1646
!
line con 0
line vty 0
login authentication test
line vty 1 4
!
```



# 44 VRRP

## 44.1

VRRP (Virtual Router Redundancy Protocol )

VRRP VRRP

VRRP

RFC 2338 VRRP IP VRRP

VRRP IP

IP  
VRRP

VRRP

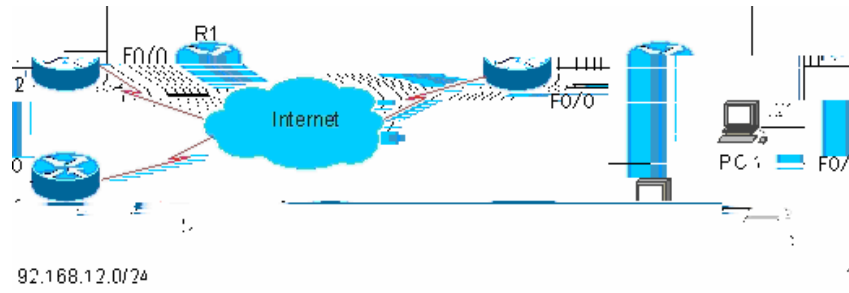

1 VRRP

| VRRP  |                 | 1  |    | 1     |  | R1 R2 |  | VRRP |  |
|-------|-----------------|----|----|-------|--|-------|--|------|--|
| Fa0/0 | 192.168.12.0/24 | R1 | R2 | Fa0/0 |  |       |  | VRRP |  |
|       | VRRP            | IP |    |       |  |       |  | VRRP |  |
|       | VRRP            |    |    |       |  |       |  | VRRP |  |

VRRP

B

```
Ruijie(config-if)# no vrrp group ip ipaddress [secondary] VRRP
```

|       |           |    |      |
|-------|-----------|----|------|
| Group | 1~255     | IP | VRRP |
|       | Secondary | IP | IP   |



VRRP IP (Primary Secondary) 0 1 Tf0.004 Tc 4.894 0 Td4FA310/G24



Level 1~254 VRRP IP IP  
 VRRP VRRP 255 VRRP  
 VRRP Master ( )

### 44.3.7 VRRP

VRRP

VRRP

VRRP ( )

| Ruijie(config-if)# <b>vrrp group track</b><br><i>interface-type number</i><br>[ <i>interface -priority</i> ] | VRRP |
|--|------|
| Ruijie(config-if)# <b>no vrrp group track</b><br><i>interface-type number</i>                                | VRRP |

1~255 VRRP Interface -Priority Interface -Priority  
 10



( Routed Port SVI Loopback Tunnel )

### 44.3.8 VRRP IP

VRRP IP IP ping  
 VRRP VRRP ( ) interval  
 timeout

| Ruijie(config-if)# <b>vrrp group track</b><br><i>ip-address</i> [[[ <b>interval</b> <i>interval-value</i> ]<br><b>timeout</b> <i>timeout-value</i> ] <i>priority</i> ] | VRRP IP |
|--|---------|





### 44.3.11 VRRP

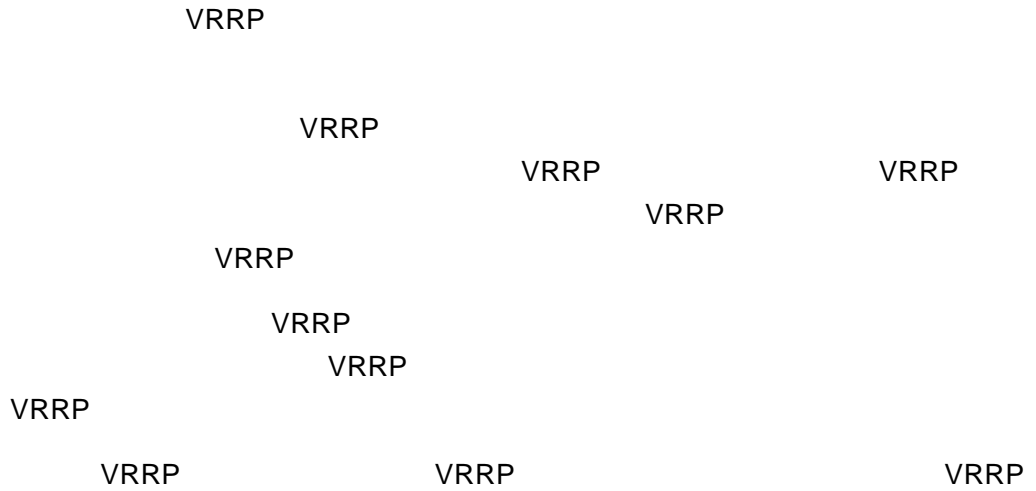

|  |      |
|--|------|
|  |      |
| Ruijie(config-if)# <b>vrrp delay { minimum min-seconds   reload reload-seconds }</b> | VRRP |
| Ruijie(config-if)# <b>no vrrp delay</b>  | VRRP |

VRRP

VRRP

0~60

## 44.4 VRRP

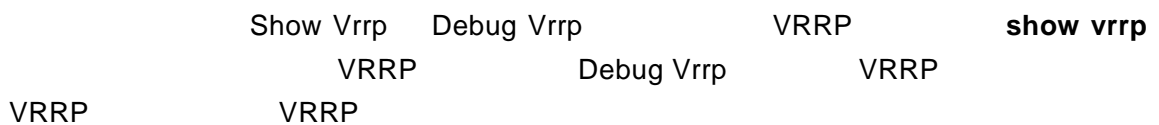

### 44.4.1 show vrrp

| show vrrp  | VRRP |
|--|------|
| Ruijie# <b>show vrrp [brief   group]</b>               | VRRP |
| Ruijie# <b>show vrrp interface type number [brief]</b> | VRRP |

### 1. show vrrp

```

Ruijie# show vrrp
GigabitEthernet 0/0 - Group 1
State is Backup
Virtual IP address is 192.168.201.1 configured
Virtual MAC address is 0000.5e00.0101
Advertisement interval is 3 sec
Preemption is enabled
min delay is 0 sec
Priority is 100
Master Router is 192.168.201.213 , pritority is 120
Master Advertisement ii4.96652i69t is0
Masteshshn6(t ii4.96652i69t)6( is)9 rti0
GigabitEthernet 0/0 - Group 26(0)6( )TJT*[(S)6(tate)6( is)][(M)6(aste)6(1)6(
Virtual MAC address is 0000.5e00.010
Advertisement interval is 3 sec
Preemption is enabled

Priority is 120
Master Router is 192.168.20176(0)(6(blocrtu)6),6(0)prPityss0120
Master Advertisement ii4.96652i69t is0
Masteshshn6(t ii4.96652i69t)6( is)9 rti0

```

| Interface          | Grp | Pri | Time | Own | Pre | State  | Master addr     | Group addr    |
|--------------------|-----|-----|------|-----|-----|--------|-----------------|---------------|
| GigabitEthernet0/0 | 1   | 100 | -    | -   | P   | Backup | 192.168.201.213 | 192.168.201.1 |
| GigabitEthernet0/0 | 2   | 120 | -    | -   | P   | Master | 192.168.201.217 | 192.168.201.2 |

### VRRP

| IP | Master | IP |
|----|--------|----|
|----|--------|----|

### 3. show vrrp interface

```
Ruijie# show vrrp interface GigabitEthernet 0/0
```

```
GigabitEthernet 0/0 - Group 1
```

```
State is Backup
```

```
Virtual IP address is 192.168.201.1 configured
```

```
Virtual MAC address is 0000.5e00.0101
```

```
Advertisement interval is 3 sec
```

```
Preemption is enabled
```

```
min delay is 0 sec
```

```
Priority is 100
```

```
Master Router is 192.168.201.213 , pritority is 120
```

```
Master Advertisement interval is 3 sec
```

```
Master Down interval is 9 sec
```

```
[(R)6(uiji)6(e# )]TJ/TT4 1 Tf4.966 0 Td[(sh)6(ow v)6(r653 )6(s9 T6(se)6(c)6
```

|                                      |      |
|--------------------------------------|------|
| <b>Ruijie# debug vrrp errors</b>     | VRRP |
| <b>Ruijie# no debug vrrp errors</b>  | VRRP |
| <b>Ruijie# debug vrrp events</b>     | VRRP |
| <b>Ruijie# no debug vrrp events</b>  | VRRP |
| <b>Ruijie# debug vrrp packets</b>    | VRRP |
| <b>Ruijie# no debug vrrp packets</b> | VRRP |
| <b>Ruijie# debug vrrp state</b>      | VRRP |
| <b>Ruijie# no debug vrrp state</b>   | VRRP |

```

192.168.201.213 VRRP 1 VRRP
IP 192.168.1.1 VRRP 1

```

### 3. debug vrrp events

```
Ruijie# debug vrrp events
```

```
Ruijie#
```

```
VRRP: Grp 1 Event - Advert higher or equal priority
```

```
VRRP: Grp 1 Event - Advert higher or equal priority
```

```
VRRP: Grp 1 Event - Advert higher or equal priority
```

```
Ruijie#
```

```

VRRP VRRP (Advertisement)

```

### 4. debug vrrp packets

```
Ruijie# debug vrrp packets
```

```
Ruijie#
```

```
VRRP: Grp 2 sending Advertisement checksum DD4D
```

```
VRRP: Grp 2 sending Advertisement checksum DD4D
```

```
VRRP: Grp 2 sending Advertisement checksum DD4D
```

```

VRRP 2 VRRP VRRP 0XDD4D

```

```
Ruijie# debug vrrp packets
```

```
Ruijie#
```

```
VRRP: Grp 1 Advertisement priority 120, ipaddr 192.168.201.213
```

```
VRRP: Grp 1 Advertisement priority 120, ipaddr 192.168.201.213
```

```
VRRP: Grp 1 Advertisement priority 120, ipaddr 192.168.201.213
```

```

192.168.201.213 VRRP 1 VRRP
120

```

### 5. debug vrrp state

```
Ruijie# debug vrrp state
```

```
VRRP State debugging is on
```

```
Ruijie#
```

```
2VRRP-6-STATECHANGE: GigabitEthernet0/0 Grp 2 state Master -> Backup
```

```
%VRRP-6-STATECHANGE: GigabitEthernet 0/0 Grp 2 state Master -> Init
Ruijie#
```

```
GigabitEthernet 0/0      VRRP      Master Backup      Init
```

## 44.5 VRRP

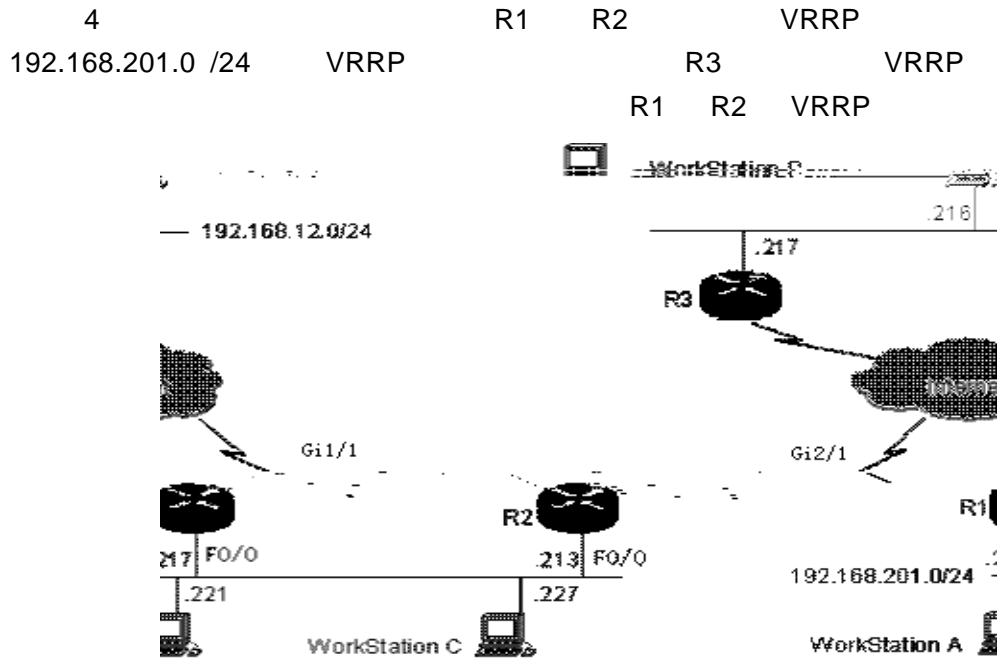

```
4      VRRP
R3
R3
!
!
hostname "R3"
!
!
!
interface GigabitEthernet 0/0
no switchport
ip address 192.168.12.217 255.255.255.0
!
interface GigabitEthernet 1/1
no switchport
ip address 60.154.101.5 255.255.255.0
!
```

```
interface GigabitEthernet 2/1
no switchport
ip address 202.101.90.61 255.255.255.0
!
router ospf
network 202.101.90.0 0.0.0.255 area 10
network 192.168.12.0 0.0.0.255 area 10
network 60.154.101.0 0.0.0.255 area 10
!
!
!
end
```

## 44.5.1 VRRP

```

      4                               (192.168.201.0/24)
R1   R2                               IP
192.168.201.1       192.168.201.1   (
192.168.12.0/24)   R1       VRRP   Master
      R1               (192.168.201.)       R1
                  R2               (192.168.201.1)
                  R1   R2
                  R1
!
!
hostname "R1"
!
!
interface GigabitEthernet 0/0
no switchport
ip address 192.168.201.217 255.255.255.0
vrrp 1 priority 120
vrrp 1 timers advertise 3
vrrp 1 ip 192.168.201.1
!
interface GigabitEthernet 2/1
no switchport
ip address 202.101.90.63 255.255.255.0
!
router ospf
```

```
network 202.101.90.0 0.0.0.255 area 10
network 192.168.201.0 0.0.0.255 area 10
!
```

## R2

```
!
hostname "R2"
!
interface GigabitEthernet 0/0
no switchport
ip address 192.168.201.213 255.255.255.0
vrrp 1 ip 192.168.201.1
vrrp 1 timers advertise 3
!
interface GigabitEthernet 1/1
no switchport
ip address 60.154.101.3 255.255.255.0
!
!
router ospf
network 60.154.101.0 0.0.0.255 area 10
network 192.168.201.0 0.0.0.255 area 10
!
!
end
```

|                 |    |    |      |   |     |      |    |
|-----------------|----|----|------|---|-----|------|----|
|                 | R1 | R2 | VRRP | 1 |     |      | IP |
| (192.168.201.1) |    |    | VRRP |   | R1  | VRRP |    |
| 120             |    | R2 | VRRP |   | 100 |      | R1 |

```
(192.168.201.1)          R2
                        R1          GigabitEthernet 2/1
                        VRRP
                        R1  R2
```

```
    R1
```

```
!
!
hostname "R1"
!
!
interface GigabitEthernet 0/0
no switchport
ip address 192.168.201.217 255.255.255.0
vrrp 1 priority 120
vrrp 1 timers advertise 3
vrrp 1 ip 192.168.201.1
vrrp 1 track GigabitEthernet 2/1 30
!

interface GigabitEthernet 2/1
no switchport
ip address 202.101.90.63 255.255.255.0
!
router ospf
network 202.101.90.0 0.0.0.255 area 10
network 192.168.201.0 0.0.0.255 area 10
!
!
end
```

```
    R2
```

```
!
!
hostname "R2"
!
!
interface GigabitEthernet 0/0
no switchport
ip address 192.168.201.213 255.255.255.0
vrrp 1 ip 192.168.201.1
vrrp 1 timers advertise 3
!
```

```
interface GigabitEthernet 1/1
no switchport
ip address 60.154.101.3 255.255.255.0
!
router ospf
network 60.154.101.0 0.0.0.255 area 10
network 192.168.201.0 0.0.0.255 area 10
!
!
```

```

      R1  R2      VRRP      1      VRRP
(      )      IP  (192.168.201.1)      VRRP
      R2      R2  VRRP      (Advertisement)      3
      R1  VRRP      120      R2  VRRP
      100      R1      Master      R1
Master      GigabitEthernet 2/1
```

```
ip address 192.168.201.217 255.255.255.0
vrrp 1 timers advertise 3
vrrp 1 ip 192.168.201.1
vrrp 2 priority 120
vrrp 2 timers advertise 3
vrrp 2 ip 192.168.201.2
vrrp 2 track GigabitEthernet 2/1 30
!
interface GigabitEthernet 2/1
no switchport
ip address 202.101.90.63 255.255.255.0
!
router ospf
network 202.101.90.0 0.0.0.255 area 10
network 192.168.201.0 0.0.0.255 area 10
!
!
end
```

## R2

```
!
!
hostname "R2"
!
!
interface Loopback 0
ip address 20.20.20.5 255.255.255.0
!
interface GigabitEthernet 0/0
no switchport
ip address 192.168.201.213 255.255.255.0
vrrp 1 ip 192.168.201.1
vrrp 1 timers advertise 3
vrrp 1 priority 120
vrrp 2 ip 192.168.201.2
vrrp 2 timers advertise 3
!
interface GigabitEthernet 1/1
no switchport
ip address 60.154.101.3 255.255.255.0
!
router ospf
```





---

# 45

## 45.1

### 45.1.1

- CPU
- CPU

### 45.1.2 CPU

| show cpu         | CPU | CPU |
|------------------|-----|-----|
| Ruijie# show cpu | CPU |     |

Ruijie

#### show cpu

```
Ruijie# show cpu
=====
      CPU Using Rate Information
CPU utilization in five seconds: 25%
CPU utilization in one minute  : 20%
CPU utilization in five minutes: 10%
 NO   5Sec   1Min   5Min   Process
  0    0%    0%    0%    LISR INT
  1    7%    2%    1%    HISR INT
  2    0%    0%    0%    ktimer
  3    0%    0%    0%    atimer
  4    0%    0%    0%    printk_task
  5    0%    0%    0%    waitqueue_process
  6    0%    0%    0%    tasklet_task
  7    0%    0%    0%    kevents
  8    0%    0%    0%    snmpd
  9    0%    0%    0%    snmp_trapd
 10    0%    0%    0%    mtblock
```

---

|    |    |    |    |                         |
|----|----|----|----|-------------------------|
| 11 | 0% | 0% | 0% | gc_task                 |
| 12 | 0% | 0% | 0% | Context                 |
| 13 | 0% | 0% | 0% | kswapd                  |
| 14 | 0% | 0% | 0% | bdflush                 |
| 15 | 0% | 0% | 0% | kupdate                 |
| 16 | 0% | 3% | 1% | ll_mt                   |
| 17 | 0% | 0% | 0% | ll main process         |
| 18 | 0% | 0% | 0% | bridge_relay            |
| 19 | 0% | 0% | 0% | dlx_task                |
| 20 | 0% | 0% | 0% | secu_policy_task        |
| 21 | 0% | 0% | 0% | dhcpc_task              |
| 22 | 0% | 0% | 0% | dhcpsnp_task            |
| 23 | 0% | 0% | 0% | igmp_snp                |
| 24 | 0% | 0% | 0% | mstp_event              |
| 25 | 0% | 0% | 0% | GVRP_EVENT              |
| 26 | 0% | 0% | 0% | rldp_task               |
| 27 | 0% | 2% | 1% | rerp_task               |
| 28 | 0% | 0% | 0% | reup_event_handler      |
| 29 | 0% | 0% | 0% | tpp_task                |
| 30 | 0% | 0% | 0% | ip6timer                |
| 31 | 0% | 0% | 0% | rtadvd                  |
| 32 | 0% | 0% | 0% | tnet6                   |
| 33 | 2% | 0% | 0% | tnet                    |
| 34 | 0% | 0% | 0% | Tarptime                |
| 35 | 0% | 0% | 0% | gra_arp                 |
| 36 | 0% | 0% | 0% | Ttcptimer               |
| 37 | 8% | 1% | 0% | ef_res                  |
| 38 | 0% | 0% | 0% | ef_rcv_msg              |
| 39 | 0% | 0% | 0% | ef_inconsistent_daemon  |
| 40 | 0% | 0% | 0% | ip6_tunnel_rcv_pkt      |
| 41 | 0% | 0% | 0% | res6t                   |
| 42 | 0% | 0% | 0% | tunrt6                  |
| 43 | 0% | 0% | 0% | ef6_rcv_msg             |
| 44 | 0% | 0% | 0% | ef6_inconsistent_daemon |
| 45 | 0% | 0% | 0% | imid                    |
| 46 | 0% | 0% | 0% | nsmd                    |
| 47 | 0% | 0% | 0% | ripd                    |
| 48 | 0% | 0% | 0% | ripngd                  |
| 49 | 0% | 0% | 0% | ospfd                   |
| 50 | 0% | 0% | 0% | ospf6d                  |
| 51 | 0% | 0% | 0% | bgpd                    |
| 52 | 0% | 0% | 0% | pimd                    |

---

---

|    |    |    |    |                |
|----|----|----|----|----------------|
| 53 | 0% | 0% | 0% | pim6d          |
| 54 | 0% | 0% | 0% | pdmd           |
| 55 | 0% | 0% | 0% | dvmrpd         |
| 56 | 0% | 0% | 0% | vty_connect    |
| 57 | 0% | 0% | 0% | aaa_task       |
| 58 | 0% | 0% | 0% | Tlogtrap       |
| 59 | 0% | 0% | 0% | dhcp6c         |
| 60 | 0% | 0% | 0% | sntp_recv_task |
| 61 | 0% | 0% | 0% | ntp_task       |
| 62 | 0% | 0% | 0% | sla_daemon     |
| 63 | 0% | 3% | 1% | track_daemon   |
| 64 | 0% | 0% | 0% | pbr_guard      |
| 65 | 0% | 0% | 0% | vrrpd          |
| 66 | 0% | 0% | 0% | psnpsd         |
| 67 | 0% | 0% | 0% | igsnpd         |
| 68 | 0% | 0% | 0% | coa_recv       |
| 69 | 0% | 0% | 0% | co_oper        |
| 70 | 0% | 0% | 0% | co_mac         |
| 71 | 0% | 0% | 0% | radius_task    |
| 72 | 0% | 0% | 0% | tac+_acct_task |
| 73 | 0% | 0% | 0% | tac+_task      |
| 74 | 0% | 0% | 0% | dhcpcd_task    |
| 75 | 0% | 0% | 0% | dhcps_task     |
| 76 | 0% | 0% | 0% | dhcpping_task  |
| 77 | 0% | 0% | 0% | dhcpc_task     |
| 7  | 0% |    |    | co_mac         |

---

|     |    |    |    |                        |
|-----|----|----|----|------------------------|
| 95  | 0% | 0% | 0% | conf_dispatch_task     |
| 96  | 0% | 0% | 0% | devprob_task           |
| 97  | 0% | 0% | 0% | rdp_snd_thread         |
| 98  | 0% | 0% | 0% | rdp_rcv_thread         |
| 99  | 0% | 0% | 0% | rdp_slot_change_thread |
| 100 | 4% | 2% | 1% | datapkt_rcv_thread     |

---

```

CPU 70% 80%
Ruijie# configure terminal //
Ruijie(config)# cpu-log log-limit 70 80 // CPU
CPU 80%
Oct 20 15:47:01 %SYSCHECK-5-CPU_USING_RATE: CPU utilization in one
minute : 95% Using most cpu's task is ktimer : 94%
CPU 70%
Oct 20 15:47:01 %SYSCHECK-5-CPU_USING_RATE: CPU utilization in one
minute :68% Using most cpu's task is ktimer : 60%
Oct 20 15:47:01 %SYSCHECK-5-CPU_USING_RATE: The CPU using rate has
down!
```

---

# 46

## 46.1

### 46.1.1

Threshold

CPU

CLI

MIB

### 46.1.2

#### 46.1.2.1 CPU

CPU

CPU

MIB

log

#### 46.1.2.2

MIB

log

#### 46.1.2.3

normal condition  
warning condition

alert condition

log

log

log

**%SYS-1-TEMP\_STATE: System detected temperature is in warning condition.**

log

**%SYS-1-TEMP\_STATE: System detected temperature is in alert condition.**

log

**%SYS-1-TEMP\_STATE: System detected temperature is in normal condition.**

## 46.2

| CPU | 90 | 100 |
|-----|----|-----|
|     | 90 | 100 |
|     | 90 | 100 |

## 46.3

- CPU
- 
- 

### 46.3.1 CPU

| <b>Step 1</b> | Ruijie# <b>configure terminal</b>  |              |
|---------------|--|--------------|
| <b>Step 2</b> | Ruijie(config)# <b>threshold set cpu</b><br>[M1   M2   slot <i>n</i>   member <i>n</i> ] <i>warning_value</i><br><i>critical_value</i> | CPU<br>1~100 |

**no threshold set cpu**

### 46.3.2

| <b>Step 1</b> | Ruijie# <b>configure terminal</b>   |       |
|---------------|---|-------|
| <b>Step 2</b> | Ruijie(config)# <b>threshold set memory</b><br>[M1   M2   slot <i>n</i>   member <i>n</i> ] <i>warning_value</i><br><i>critical_value</i> | 1~100 |

**no threshold set memory**

---

### 46.3.3

| <code>show threshold cpu</code>    | CPU |
|------------------------------------|-----|
| <code>show threshold memory</code> |     |



## 46.4

### 46.4.1

```
CPU                               80  90                               50  80

Ruijie# configure terminal
Enter configuration commands, one per line. End with CNTL/Z.

Ruijie(config)#threshold set cpu member 1 80 90

Ruijie(config)#threshold set temperature member 1 60 80
```

### 46.4.2

```
show threshold

Ruijie#show threshold cpu
Device      Warning    Critical
Member 1:   80        90

Ruijie#show threshold memory
Device      Warning    Critical
Member 1:   90        100

Ruijie#show threshold temperature
Device      Warning    Critical
```

---

Member 1:

60

80

CPU



|      |                                |
|------|--------------------------------|
|      | <b>memory-lack exit-policy</b> |
| low  | OVERFLOW                       |
| high | OVERFLOW                       |

3.

### 47.1.3

**memory-lack exit-policy** lower  
BGP OSPF RIP PIM-SM

**memory-lack exit-policy [bgp|ospf|pim-sm|rip]**

|  |  |
|--|--|
|  |  |
| Ruijie(config)# <b>memory-lack exit-policy [bgp ospf pim-sm rip]</b> |  |

**no memory-lack exit-policy** lower

lower ( show memory lower )

BGP

---

**show memory protocol**

|                              |  |
|------------------------------|--|
|                              |  |
| Ruijie#show memory protocols |  |

**show memory protocols**

Ruijie# show memory protocols

=====

| protocol | memory(byte) |
|----------|--------------|
| BGP      | 102000000    |
| OSPF     | 24000000     |
| RIP      | 10000000     |
| PIM      | 50000000     |
| LDP      | 20000000     |
| Total    | 206000000    |



BGP OSPF

RIP LDP PIM ISIS

---

## 48 USB

### 48.1

```
usb          U          FAT  U
U          U
```

### 48.2

```
Usb          usb
```

```
0:1:18:57 Ruijie: %5:USB Device Found ..... <USB Mass Storage Device>!
```

| Ruijie# <b>makefs dev</b> <i>dev_file</i> <b>fs</b><br><i>fs_name</i> | <i>dev_file</i><br><i>fs_name</i> |
|---|-----------------------------------|

U

Ruijie# **makefs dev** /dev/uba/disc0/part1 **fs** vfat

U fat32



U vfat

### 48.2.3 USB

| Ruijie# <b>show usb</b> | usb |
|-------------------------|-----|

CLI

**show usb**

USB

USB

CLI



Ruijie# **usb remove**

## 49 SD

### 49.1 SD

#### 49.1.1 SD

```
SD          sd          FAT32      sd
sd          sd
```

#### 49.1.2

```
sd          sd
```

```
*Jan 14 15:43:06: %SD_CARD-5-INSERT: SD Card install successfully!
```

```
*Jan 14 15:43:06: %SD-5-SD_DISK_PARTITION: SD_DISK_PARTITION found,
/dev/sd0/disc0/part1 to /mnt/sd0, size 1017643008B(970MB).
```

```
/dev/sd0/disc0/part1          /mnt/sd0          size
u          970MB
```

#### 49.1.3

```
sd          dir copy del      sd
          sd          flash
Ruijie# cd /mnt/sd0 # sd
Ruijie# copy flash: a.txt flash: /b.txt # sd          a.txt
          dir /          flash          b.txt
          sd
```

#### 49.1.4 sd

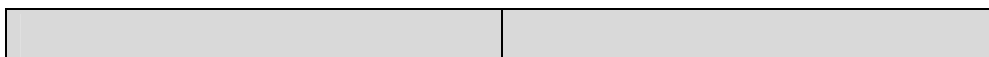

Ruijie#

Now, you can drag out the sd card.

sd

SD card is currently in use, You can't remove it, please try later.

## 49.2 SD

|                                   |           |
|-----------------------------------|-----------|
|                                   |           |
| Ruijie(config-if)# <b>show sd</b> | showsd SD |

Ruijie#show sd

Product name: SD

Product serial number: d72185e3

Disk Partitions:

1: /dev/sd0/disk0/part1 --> /mnt/sd0

size 1017643008B(970MB).



---

# 50

## 50.1

UP DOWN

VTY

FLASH

### 50.1.1

**<priority> seq no: timestamp sysname**

**%ModuleName-severity-MNEMONIC: description**

< > - -

8

<189> 226:Mar 5 02:09:10 S3250 %SYS-5-CONFIG\_I: Configured from console by console



Server

Syslog

---

## 50.2

### 50.2.1

Syslog

FLASH

---

|                                      |  |
|--------------------------------------|--|
|                                      |  |
| Ruijie(config)# <b>logging on</b>    |  |
| Ruijie(config)# <b>no logging on</b> |  |



## 50.2.2

|  |              |
|--|--------------|
|  |              |
| Ruijie(config)# <b>logging buffered</b><br>[ <i>buffer-size</i>   <i>level</i> ]                       |              |
| Ruijie# <b>terminal monitor</b>  | VTY          |
| Ruijie(config)# <b>logging host</b>  | Sever Syslog |
| Ruijie(config)# <b>logging file</b><br><b>flash:filename</b> [ <i>max-file-size</i> ] [ <i>level</i> ] | FLASH        |

Logging Buffere

**show logging**

---

Logging File Flash

FLASH

TXT

More Flash Filename

Flash



FLASH

FLASH

FLASH

FLASH

FLASH

### 50.2.3

| Ruijie(config)# <b>service timestamps</b><br><i>message-type</i> [uptime   datetime] |    |
|--|----|
| Ruijie(config)# <b>no service timestamps</b><br><i>message-type</i>                  | TX |

---

|  |  |
|--|--|
| Ruijie(config)# <b>service sysname</b> |  |
|--|--|

## 50.2.5



---

## 50.2.8

| Ruijie(config)# <b>logging rate-limit</b><br><i>number</i> |  |
|--|--|
| Ruijie(config)# <b>no logging</b><br><b>rate-limit</b>     |  |

## 50.2.9

| Ruijie(config)# <b>logging console</b><br><i>level</i>                           |                |
|--|----------------|
|  | VTY ( telnet ) |
| Ruijie(config)# <b>logging buffered</b><br>[ <i>buffer-size</i>   <i>level</i> ] |                |
| Ruijie(config)# <b>logging file</b><br><b>flash:filename</b> [                   |                |



---

|    |  |
|----|--|
| 3  | system daemons                           |
| 4  | security/authorization messages          |
| 5  | messages generated internally by syslogd |
| 6  | line printer subsystem                   |
| 7  | network news subsystem                   |
| 8  | UUCP subsystem                           |
| 9  | clock daemon                             |
| 10 | security/authorization messages          |
| 11 | FTP daemon                               |
| 12 | NTP subsystem                            |
| 13 | log audit                                |
| 14 | log alert                                |
| 15 | clock daemon                             |
| 16 | local use 0 (local0)                     |
| 17 | local use 1 (local1)                     |
| 18 | local use 2 (local2)                     |
| 19 | local use 3 (local3)                     |
| 20 | local use 4 (local4)                     |
| 21 | local use 5 (local5)                     |
| 22 | local use 6 (local6)                     |
| 23 | local use 7 (local7)                     |

23

## 50.2.11

Syslog Server

---

LOG

/ LOG

---

Ruijie(config)#

# 51 RLOG

## 51.1

rlog

rlog

nat

web

## 51.2

### 51.2.1

udp

| Ruijie(config)# <b>rlog server</b> <i>server-ip</i><br>[ <b>vrf</b> <i>vrf-name</i> ] | ip VRF |
|---|--------|
| Ruijie(config)# <b>no rlog server</b>   |        |



**ip session log-on**

---

## 51.2.2

|   |       |
|---|-------|
|   |       |
| Ruijie(config)# <b>rlog mtu</b> <i>number</i><br>Ruijie(config)# <b>no rlog mtu</b>                 | 1500  |
| Ruijie(config)# <b>rlog port</b> <i>number</i><br>Ruijie(config)# <b>no rlog port</b>               | 10000 |
| Ruijie(config)# <b>rlog export-rate</b> <i>number</i><br>Ruijie(config)# <b>no rlog export-rate</b> | 1000  |

---



---

## 51.2.3

|  |  |
|--|--|
|  |  |
|--|--|

Ruijie(config)# **rlog test**

0

---

web

web

**51.4**

web

# 52 SNMP

## 52.1 SNMP

### 52.1.1

SNMP Simple Network Manger Protocol 1988 8  
RFC1157 SNMP  
SNMP

SNMP

SNMP /

- SNMP
- SNMP
- MIB

SNMP SNMP NMS (Network  
Management System) NMS HP OpenView Cisco-4JP



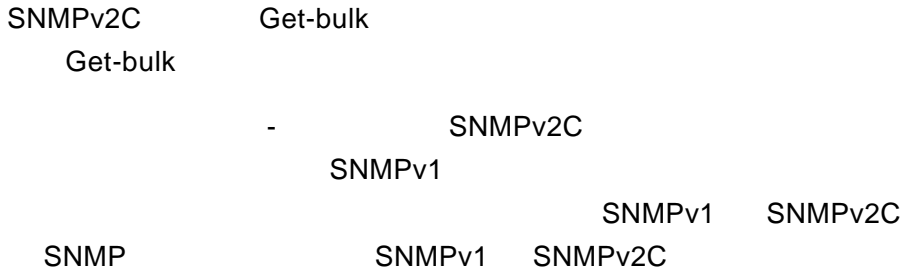

### 52.1.3 SNMP

- |                     |          |       |                            |
|---------------------|----------|-------|----------------------------|
| SNMP                | NMS      | Agent | 6                          |
| 1. Get-request      | NMS      | Agent |                            |
| 2. Get-next-request | NMS      | Agent |                            |
| 3. Get-bulk         | NMS      | Agent |                            |
| 4. Set-request      | NMS      | Agent |                            |
| 5. Get-response     | Agent    | Agent | NMS      3                 |
| 6. Trap             | Agent    | NMS   |                            |
| 4                   | NMS      | Agent | Agent      NMS      SNMPv1 |
|                     | Get-bulk |       |                            |

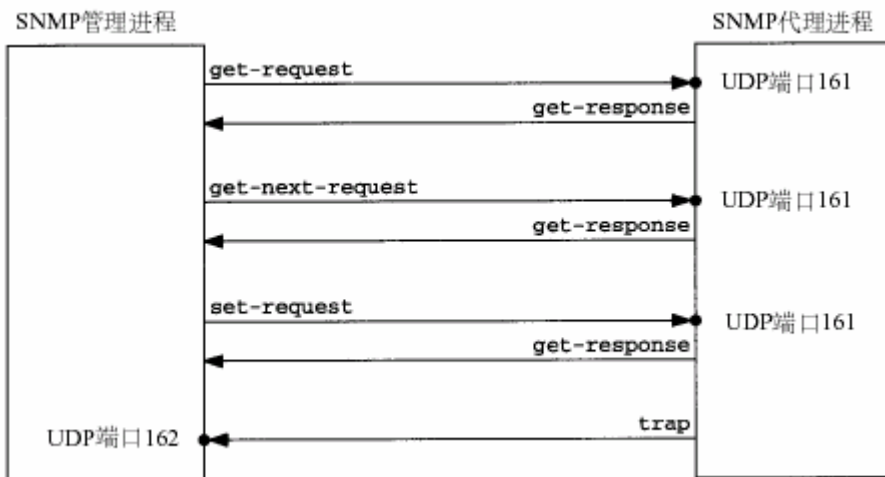

### 3 SNMP

- |     |       |     |       |     |     |       |
|-----|-------|-----|-------|-----|-----|-------|
| NMS | Agent | 3   | Agent | UDP | 161 | Agent |
|     | Trap  | UDP | 162   |     |     |       |

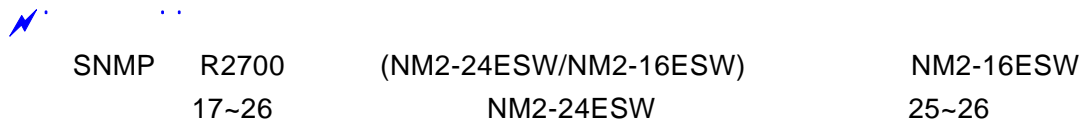

### 52.1.4 SNMP

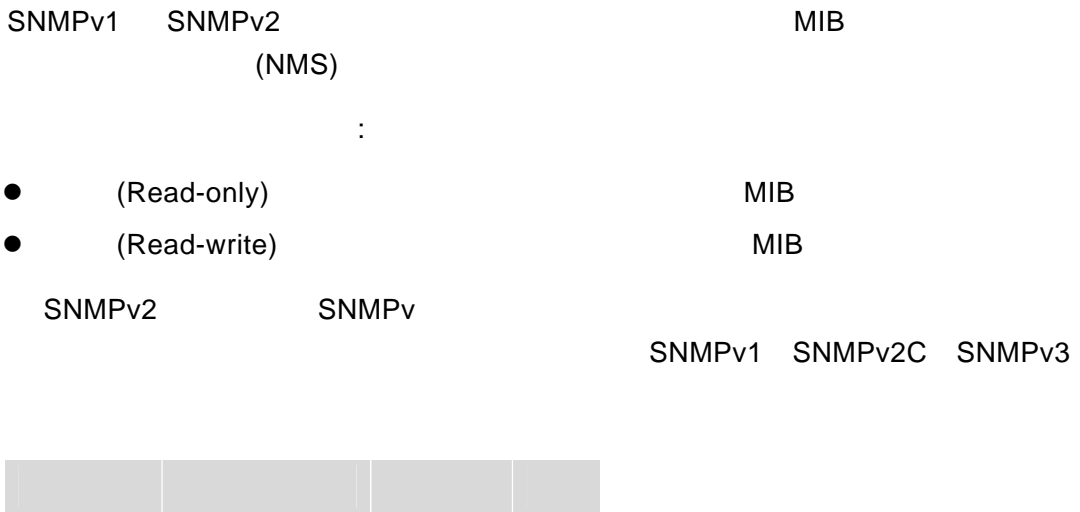

|         |    | SNMP         | SNMP | SNMP    |
|---------|----|--------------|------|---------|
|         |    | SNMP         | SNMP | SNMPv3  |
|         |    | SnmEngineID  |      |         |
|         |    | OCTET STRING | 5 32 | RFC3411 |
|         | :  |              |      |         |
| ●       | 4  |              | IANA | HEX     |
| ●       | 5  |              |      |         |
| 0       |    |              |      |         |
| 1       | 4  | Ipv4         |      |         |
| 2       | 16 | Ipv6         |      |         |
| 3       | 6  | MAC          |      |         |
| 4       |    | 27           |      |         |
| 5       | 16 | 27           |      |         |
| 6-127   |    |              |      |         |
| 128-255 |    |              |      |         |

## 52.2 SNMP

SNMP

SNMP

|   |  |
|---|--|
| Ruijie(config)# <b>snmp-server community</b><br><i>string</i> [ <b>view</b> <i>view-name</i> ] [ <b>ro</b>   <b>rw</b> ] [ <b>host</b><br><i>host-ip</i> ] [ <i>num</i> ] |  |
|---|--|

NMS  
**community**

**no snmp-server**

### 52.2.2 MIB

- 
- 
- SNMPv3

MIB

|   |            |
|---|------------|
|   |            |
| Ruijie(config)# <b>snmp-server view</b><br><i>view-name oid-tree</i> { <b>include</b>  <br><b>exclude</b> }   | MIB<br>MIB |
| Ruijie(config)# <b>snmp-server group</b><br><i>groupname</i> { <b>v1</b>   <b>v2c</b>   <b>v3</b> { <b>auth</b>  <br><b>noauth</b><br>  <b>priv</b> }} [ <b>read</b> <i>readview</i> ] [ <b>write</b><br><i>writeview</i> ] [ <b>access</b> { <i>num</i>   <i>name</i> }] |            |

**no snmp-server view** *view-name*  
**view** *view-name oid-tree*  
**group** *groupname*

**no snmp-server**  
**no snmp-server**

### 52.2.3 SNMP

NMS



## 52.2.6 SNMP

SNMP

| Ruijie(config)# <b>snmp-server packetsize</b><br><i>byte-count</i> |  |
|--|--|

## 52.2.7 SNMP

SNMP

snmp

snmp

|  |       |      |
|--|-------|------|
| Ruijie(config)# <b>snmp-server enable traps</b> [type] [option]    | Agent | Trap |
| Ruijie(config)# <b>no snmp-server enable traps</b> [type] [option] | Agent | Trap |

### 52.2.10 Link Trap

| SNMP   | LinkTrap, | LinkTrap | Link      |
|--|-----------|----------|-----------|
| Ruijie(config)# <b>interface</b> interface-id        |           |          |           |
| Ruijie(config-if)# <b>[no] snmp trap link-status</b> |           |          | link trap |

Link trap:

```
Ruijie(config)# interface gigabitEthernet 1/1
Ruijie(config-if)# no snmp trap link-status
```

### 52.2.11

| Agent  | Trap |
|--|------|
| Ruijie(config)# <b>snmp-server trap-source</b> interface |      |

```
[redacted]  
Ruijie(config)#
```

SNMP logging: enabled

SNMP agent: enabled

| Bad SNMP version errors                       | SNMP        |
|---|-------------|
| Unknown community name                        |             |
| Illegal operation for community name supplied |             |
| Encoding errors                               |             |
| Get-request PDUs                              | Get-request |
| Get-next PDUs                                 | Get-next    |
| Set-request PDUs                              | Set-request |
| Too big errors (Maximum packet size 1500)     |             |

No such name errorsUnknown community na112C0CFC<1B5B8DB40(6<0EF8>-6317529D6<07FF92

sysServices  
sysORLastChange  
snmpInPkts  
snmpOutPkts  
snmpInBadVersions  
snmpInBadCommunityNames  
snmpInBadCommunityUses  
snmpInASNParseErrs  
snmpInTooBigs  
snmpInNoSuchNames  
snmpInBadValues  
snmpInReadOnlys  
snmpInGenErrs  
snmpInTotalReqVars  
snmpInTotalSetVars  
snmpInGetRequests  
snmpInGetNexts  
snmpInSetRequests  
snmpInGetResponses  
snmpInTraps  
snmpOutTooBigs  
snmpOutNoSuchNames  
snmpOutBadValues  
snmpOutGenErrs  
snmpOutGetRequests  
snmpOutGetNexts  
snmpOutSetRequests  
snmpOutGetResponses  
snmpOutTraps  
snmpEnableAuthenTraps  
snmpSilentDrops  
snmpProxyDrops  
entPhysicalEntry  
entPhysicalEntry.entPhysicalIndex  
entPhysicalEntry.entPhysicalDescr  
entPhysicalEntry.entPhysicalVendorType  
entPhysicalEntry.entPhysicalContainedIn  
entPhysicalEntry.entPhysicalClass  
entPhysicalEntry.entPhysicalParentRelPos  
entPhysicalEntry.entPhysicalName  
entPhysicalEntry.entPhysicalHardwareRev  
entPhysicalEntry.entPhysicalFirmwareRev



```

groupname: public
securityModel: v2c
securityLevel:noAuthNoPriv
readview: default
writeview: default
notifyview:

```

### show snmp view

```

Ruijie# show snmp view
default(include) 1.3.6.1
test-view(include) 1.3.6.1.2.1

```

## 52.4 SNMP

### 52.4.1

- 

|    |              |     |    |                |
|----|--------------|-----|----|----------------|
|    | NMS          | NMS | IP | 192.168.12.181 |
| IP | 192.168.12.1 |     |    | HP OpenView    |

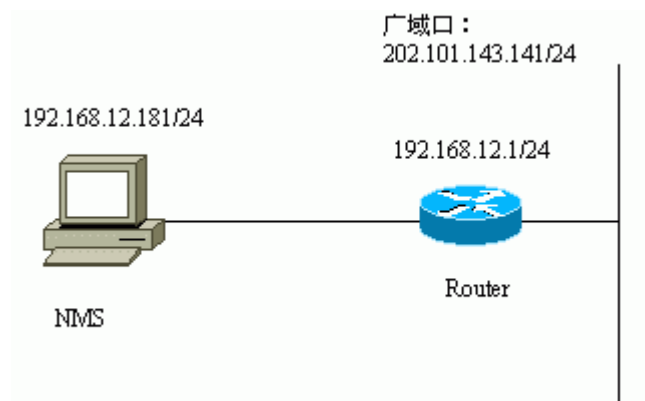

### 5 SNMP

- 

### SNMP

```

Ruijie(config)# snmp-server community public RO

```

|     |      |      |
|-----|------|------|
|     |      | SNMP |
| NMS | SNMP |      |

```
Ruijie(config)# snmp-server community private RW
```

SNMP NMS

```
Ruijie(config)# snmp-server location fuzhou
```

```
Ruijie(config)# snmp-server contact wugb@i-net.com.cn
```

```
Ruijie(config)# snmp-server chassis-id 1234567890
0987654321
```

NMS Trap

```
Ruijie(config)# snmp-server enable traps
```

```
Ruijie(config)# snmp-server host 192.168.12.181 public
```

SNMP NMS

HP OpenView

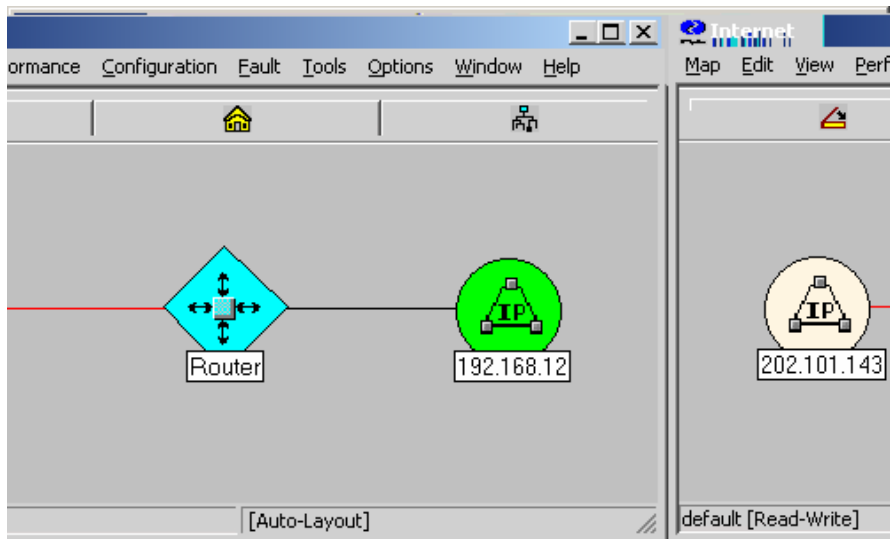

6

| MIB Browser | Community Name | Start Query Values | Name | HP OpenView  | TOOL->SNMP |
|-------------|----------------|--------------------|------|--------------|------------|
|             | Public         |                    | IP   | 192.168.12.1 | System     |
|             |                |                    | MIB  |              | MIB        |

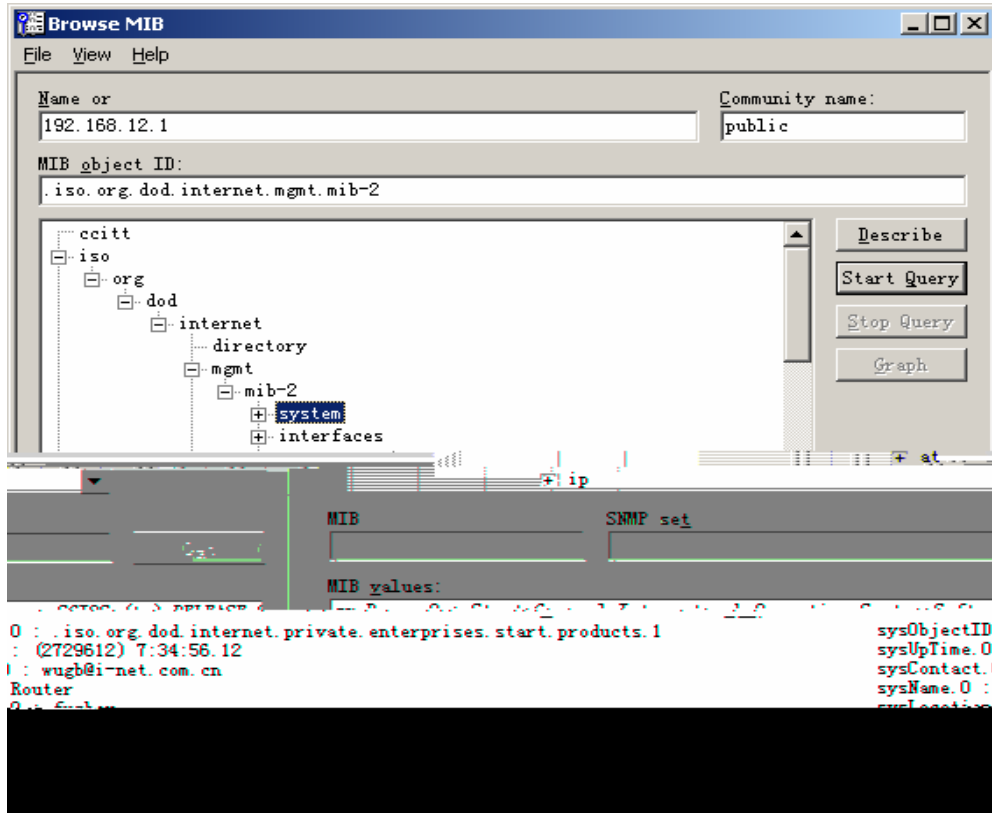

7 MIB

HP OpenView

SNMP

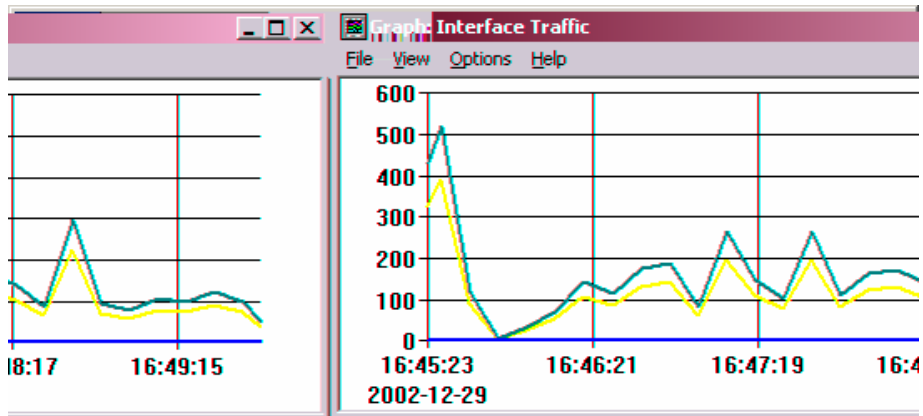

8

### 52.4.2 SNMP



```
Ruijie(config)# access-list 1 permit 192.168.12.181
Ruijie(config)# snmp-server community public RO 1

IP          192.168.12.181          SNMP
```

### 52.4.3 SNMPv3

```
SNMPv3          v3user
MIB-2(1.3.6.1.2.1) MD5
MD5-Auth      DES          DES-Priv      192.168.65.199
SNMPv3      Trap      Trap          v3user,
MD5          MD5-Auth      DES
DES-Priv

Ruijie(config)# snmp-server view v3userview 1.3.6.1.2.1 include
Ruijie (config)# snmp-server group v3usergroup v3 priv read v3userview
write v3userview
```

## 53 MIB

MIB

MIB

MIB

### 53.1 MIB

MIB

- BRIDGE-MIB (RFC1493)
- EtherLike-MIB(RFC1643)
- IF-MIB(RFC2863)
- RFC1213-MIB
- RMON1-MIB           RMON etherStats, etherHistory,alarms, events
- SNMPv2-MIB
- SNMPv3-MIB        USM   VACM

MIB

- RUIJIE-AAA-MIB
- RUIJIE -ENTITY-MIB
- RUIJIE -RIP-MIB
- RUIJIE -MEMORY-MIB

MIB

**show snmp mib**

MIB

```
Ruijie# show snmp mib
sysDescr
sysObjectID
sysUpTime
sysContact
sysName
sysLocation
sysServices
sysORLastChange
```

```
ifNumber
ifEntry
ifEntry.ifIndex
ifEntry.ifDescr
ifEntry.ifType
ifEntry.ifMtu
ifEntry.ifSpeed
ifEntry.ifPhysAddress
ifEntry.ifAdminStatus
ifEntry.ifOperStatus
ifEntry.ifLastChange
ifEntry.ifInOctets
ifEntry.ifInUcastPkts
ifEntry.ifInNUcastPkts
ifEntry.ifInDiscards
ifEntry.ifInErrors
ifEntry.ifInUnknownProtos
ifEntry.ifOutOctets
ifEntry.ifOutUcastPkts
ifEntry.ifOutNUcastPkts
ifEntry.ifOutDiscards
ifEntry.ifOutErrors
ifEntry.ifOutQLen
ifEntry.ifSpecific
.....
```

## 53.2 MIB

<http://ietf.org/rfc.html>

MIB

MIB

# 54 RMON

## 54.1

RMON Remote Monitoring IETF(Internet Engineering Task Force  
Internet )

RMON

RMON

RMON

RMON

## 54.1.4

(Event) RMON 9  
SNMP Trap

## 54.2 RMON

### 54.2.1

!=\$v\$D(oB...V#N^Q2XRDUT!#iW6!\$765xUq@AB76536

*Bucket-number*

|          |               |               |
|----------|---------------|---------------|
|          | Bucket-number |               |
| 1-65535  | 10            | Bucket-number |
| Interval | 1800          | 1-3600        |

### 54.2.3

| Ruijie(config)# <b>rmon alarm</b> <i>number variable interval</i> { <b>absolute</b>   <b>delta</b> } <b>rising-threshold</b> <i>value</i> [ <i>event-number</i> ] <b>falling-threshold</b> <i>value</i> [ <i>event-number</i> ] [ <b>owner</b> <i>ownername</i> ] |  |
|---|--|
| Ruijie(config)# <b>rmon event</b> <i>number</i> [ <b>log</b> ] [ <b>trap</b> <i>community</i> ] [ <b>description</b> <i>description-string</i> ]  |  |
| Ruijie(config)# <b>no rmon alarm</b> <i>number</i>  |  |
| Ruijie(config)# <b>no rmon event</b> <i>number</i>  |  |

*number* ( ) 1-65535

*variable*

*interval* <1-4294967295>

Absolute

Delta

*value*



#### 54.3.4.1 show rmon alarm

```
Ruijie# show rmon alarm
Alarm : 1
Interval : 1
Variable : 1.3.6.1.2.1.4.2.0
Sample type : absolute
Last value : 64
Startup alarm : 3
Rising threshold : 10
Falling threshold : 22
Rising event : 0
Falling event : 0
Owner : zhangsan
```

#### 54.3.4.2 show rmon event

```
Ruijie# show rmon event
Event : 1
Description : firstevent
Event type : log-and-trap
Community : public
Last time sent : 0d:0h:0m:0s
Owner : zhangsan
Log : 1
Log time : 0d:0h:37m:47s
Log description : ipttl
Log : 2
Log time : 0d:0h:38m:56s
Log description : ipttl
```

#### 54.3.4.3 show rmon history

```
Ruijie# show rmon history
Entry : 1
Data source : Gil/1
Buckets requested : 65535
Buckets granted : 10
Interval : 1
Owner : zhangsan
Sample : 198
Interval start : 0d:0h:15m:0s
DropEvents : 0
Octets : 67988
```

```
Pkts : 726
BroadcastPkts : 502
MulticastPkts : 189
CRCAlignErrors : 0
UndersizePkts : 0
OversizePkts : 0
Fragments : 0
Jabbers : 0
Collisions : 0
Utilization : 0
```

#### 54.3.4.4 show rmon statistics

```
Ruijie# show rmon statistics
Statistics : 1
Data source : Gil/1
DropEvents : 0
Octets : 1884085
Pkts : 3096
BroadcastPkts : 161
MulticastPkts : 97
CRCAlignErrors : 0
UndersizePkts : 0
OversizePkts : 1200
Fragments : 0
Jabbers : 0
Collisions : 0
Pkts64Octets : 128
Pkts65to127Octets : 336
Pkts128to255Octets : 229
Pkts256to511Octets : 3
Pkts512to1023Octets : 0
Pkts1024to1518Octets : 1200
Owner : zhangsan
```

IPv6

# 55 IPv6

## 55.1 IPv6

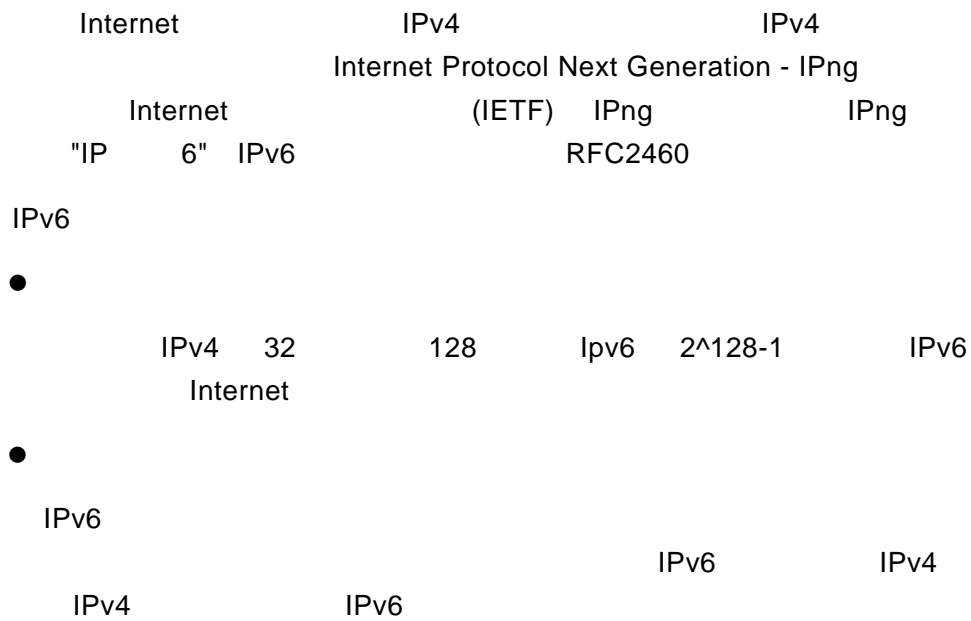

IPSec IPv4 IPv6 IPv6  
IPv6 IPv6 Authentication Header AH  
Encapsulated Security Payload ESP IP

● QoS  
IPv6 IPv6 IPv6 Flow Label  
IPv6

●  
IPv6 Neighbor Discovery Protocol IPv6  
ICMPv6 ARP ICMPv4

●  
IPv6 40 IPv6 IPv6 IPv6 IPv4  
IPv6

- IPv6
- IPv6
- IPv6
- ICMPv6
- IPv6
- MTU
- ICMPv6
- 
- IPv6
- IPv6
- IPv6
- IPv6
- Ping IPv6

### 55.1.1 IPv6

IPv6                                    X : X : X : X : X : X : X : X                    X                    4  
(16 )                                    4                                    4                                    8  
    128                                    IPv6

2001:ABCD:1234:5678:AAAA:BBBB:1200:2100  
800 : 0 : 0 : 0 : 0 : 0 : 0 : 1  
1080 : 0 : 0 : 0 : 8 : 800 : 200C : 417A

    0                                    A   F                    10   15                    0 (                    IPv6

### 55.1.2.1 Unicast Addresses

IPv6

- 
- 
- 
- IPv4 IPv6

1.

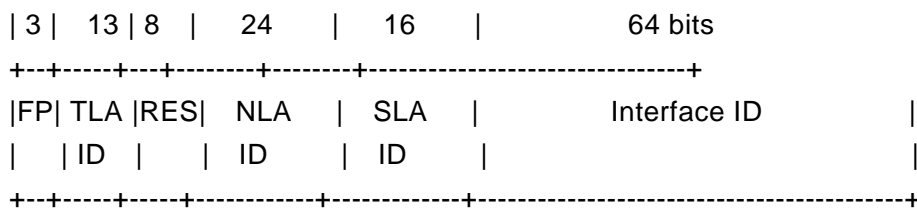

- FP (Format Prefix)

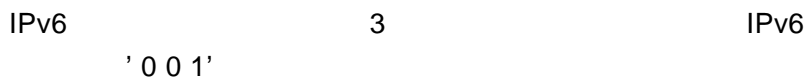

- TLA ID (Top-Level Aggregation Identifier)

8192

1 3

- RES (Reserved for future use)

8

- NLA ID (Next-Level Aggregation Identifier)







112

IPv6

FF00::/8

IPv6

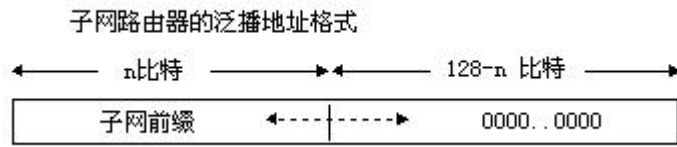

2

### 55.1.3 IPv6

IPv6

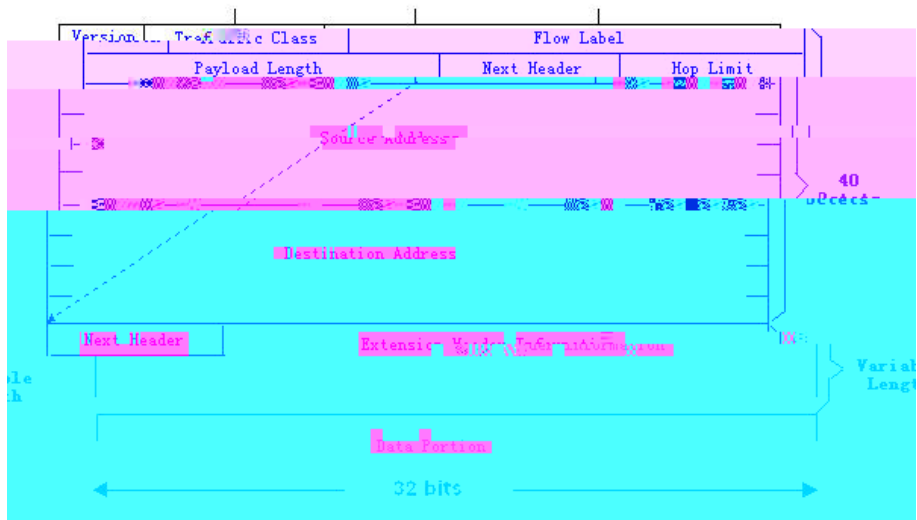

3

- |   |      |   |                  |       |
|---|------|---|------------------|-------|
|   | IPv4 | 4 | IP v 6           | 8     |
|   | 40   |   | IPv6             |       |
| ● |      |   | (Version)        |       |
|   | 4    |   | IP v 6           | 6     |
| ● |      |   | (Traffic Class)  |       |
|   | 8    |   | IPv4             | “TOS” |
| ● |      |   | (Flow Label)     |       |
|   | 20   |   |                  |       |
| ● |      |   | (Payload Length) |       |

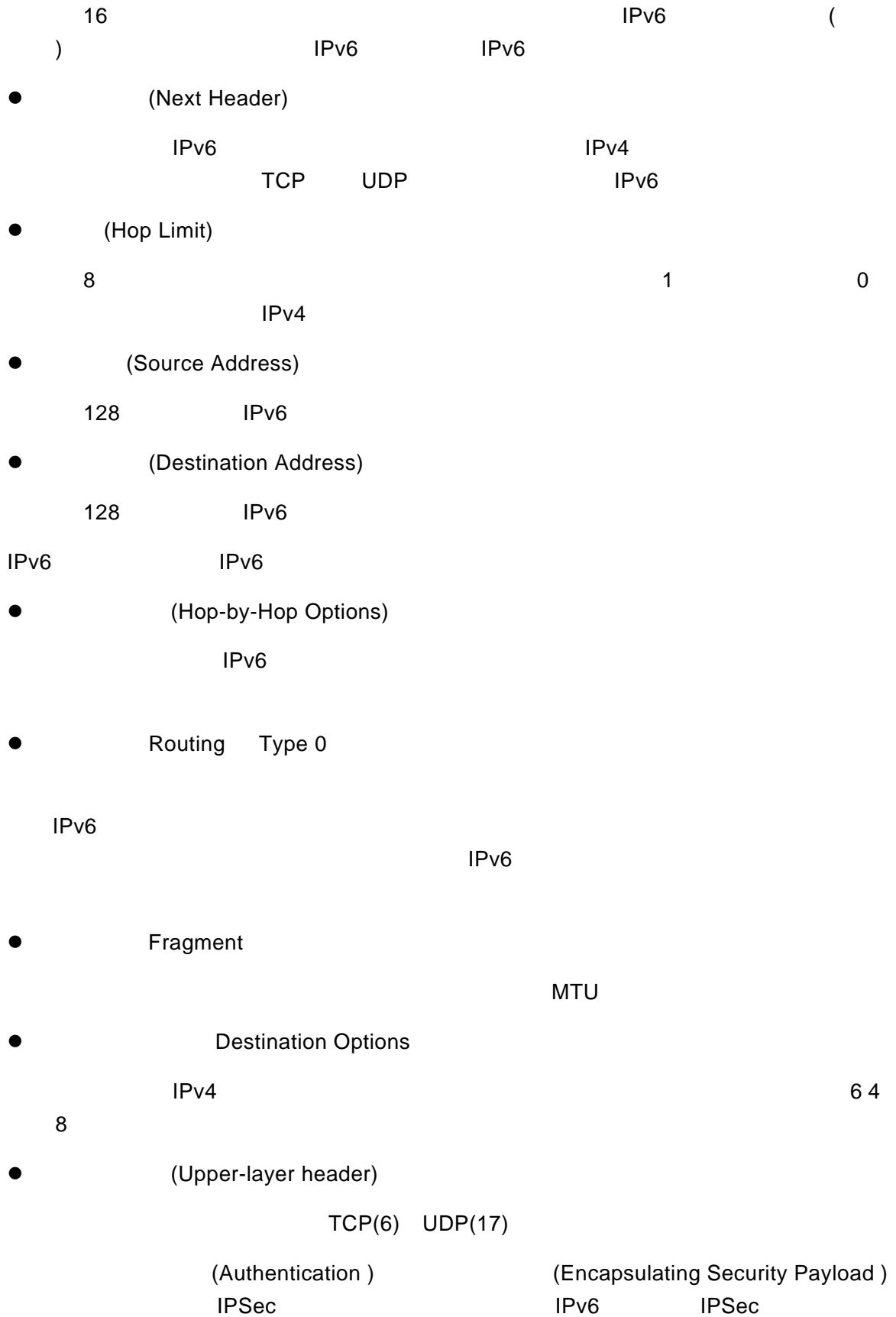

**55.1.4 IPv6**

**MTU**

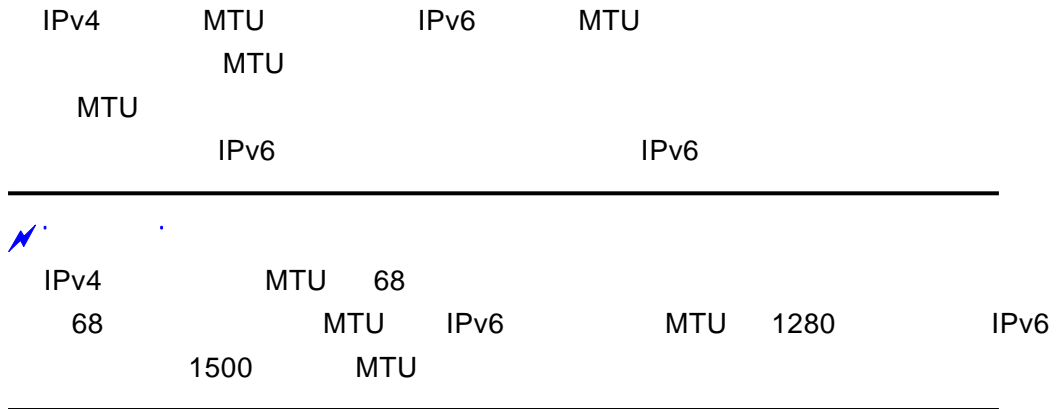

### 55.1.5 IPv6

IPv6 ICMPv6

#### 55.1.5.1 Neighbor Solicitation

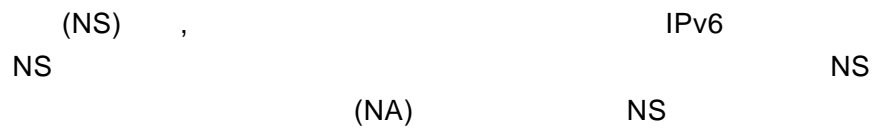

IPv6 Neighbor Discovery (Neighbor solicitation packet)



( )

Detection),  
NUD  
NUD(Neighbor Unreachability

(::)

### 55.1.5.2 (Router Advertisement)

(RA)

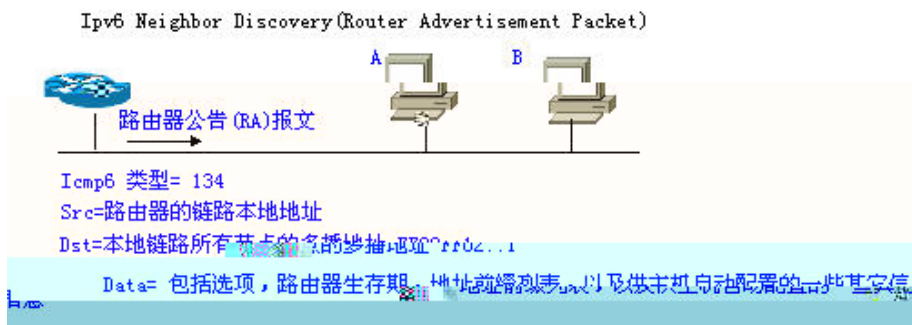

5

- IPv6
- IPv6
- ( )
- ( )
- MTU (RS) (RA)
- (0:0:0:0:0:0:0:0) (FF02::2) (RS)

(RA)

FF02::1)

(

Ra-interval

Ra-lifetime

Prefix IPv6

Rs-interval

Reachabletime

IPv6

---

1)

**no ipv6 nd suppress-ra**

2) 64

---

## 55.2 IPv6

IPv6

### 55.2.1 IPv6

IPv6

IPv6

---

IPv6

IPv6

UP  
(Anycast)

---

IPv6

|                           |  |
|---------------------------|--|
|                           |  |
| <b>configure terminal</b> |  |

|  |   |
|--|---|
| <b>interface</b> <i>interface-id</i>   |   |
| <b>ipv6 enable</b>   | IPv6<br>IPv6 IPv6   |
| <b>ipv6 address</b><br><i>ipv6-prefix/prefix-length</i><br>[ <b>eui-64</b> ] | IPv6 Eui-64<br>ipv6 ID<br>64 eui-64<br>ID/ ) ( +<br>IPv6 IPv6<br><b>enable</b> <b>no ipv6</b> |
| <b>End</b>   |   |
| <b>show ipv6 interface vlan 1</b>  | IPv6  |
| <b>copy running-config startup-config</b>                                    |   |

**no ipv6 address** *ipv6-prefix/prefix-length* [**eui-64**]

IPv6

```
Ruijie(config)# interface vlan 1
Ruijie(config-if)# ipv6 enable
Ruijie(config-if)# ipv6 address fec0:0:0:1::1/64
Ruijie(config-if)# end
Ruijie(config-if)# show ipv6 interface vlan 1
Interface vlan 1 is Up, ifindex: 2001
address(es):
Mac Address: 00:00:00:00:00:01
INET6: fe80::200:ff:fe00:1 , subnet is fe80::/64
INET6: fec0:0:0:1::1 , subnet is fec0:0:0:1::/64
Joined group address(es):
ff01:1::1
ff02:1::1
ff02:1::2
ff02:1::1:ff00:1
MTU is 1500 bytes
ICMP error messages limited to one every 10 milliseconds
ICMP redirects are enabled
ND DAD is enabled, number of DAD attempts: 1
```

```
ND reachable time is 30000 milliseconds
ND advertised reachable time is 0 milliseconds
ND retransmit interval is 1000 milliseconds
ND advertised retransmit interval is 0 milliseconds
ND router advertisements are sent every 200 seconds<240--160>
ND router advertisements live for 1800 seconds
```

## 55.2.2 ICMPv6

ICMPv6

IPv6

- 
- 
- 
- 

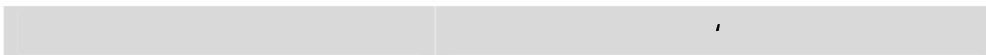

```
Ruijie (config-if)# ipv6 redirects
Ruijie (config-if)# end
Ruijie # show ipv6 interface vlan 1
Interface vlan 1 is Up, ifindex: 2001
address(es):
Mac Address: 00:d0:f8:00:00:01
INET6: fe80::2d0:f8ff:fe00:1 , subnet is fe80::/64
INET6: fec0:0:0:1::1 , subnet is fec0:0:0:1::/64
Joined group address(es):
ff01:1::1
ff02:1::1
ff02:1::2
ff02:1::1:ff00:1
MTU is 1500 bytes
ICMP error messages limited to one every 10 milliseconds
ICMP redirects are enabled
ND DAD is enabled, number of DAD attempts: 1
ND reachable time is 30000 milliseconds
ND advertised reachable time is 0 milliseconds
ND retransmit interval is 1000 milliseconds
ND advertised retransmit interval is 0 milliseconds
ND router advertisements are sent every 200 seconds<240--160>
ND router advertisements live for 1800 seconds
```

### 55.2.3

(NDP)

**no ipv6 neighbor**

SVI 1

```
Ruijie(config)# ipv6 neighbor fec0:0:0:1::100 vlan 1
00d0.f811.1234
Ruijie (config)# end
Ruijie# show ipv6 neighbors verbose fec0:0:0:1::100
IPv6 Address      Linklayer Addr  Interface
fec0:0:0:1::100   00d0.f811.1234  vlan 1
State: REACH/H Age: - asked: 0
```

### 55.2.4

2

- 0
- 

Donw      Up

|   |                 |
|---|-----------------|
|   |                 |
| <b>configure terminal</b>                           |                 |
| <b>interface vlan 1</b>                             | SVI 1           |
| <b>ipv6 nd dad attempts</b><br><i>attempts</i>      | 0               |
| <b>End</b>  |                 |
| <b>show ipv6 interface vlan 1</b>                   | SVI 1      IPv6 |
| <b>copy running-config</b><br><b>startup-config</b> |                 |

**no ipv6 nd dad attempts**

```

Ruijie# show ipv6 interface vlan 1
Interface vlan 1 is Up, ifindex: 2001
address(es):
Mac Address: 00:d0:f8:00:00:01
INET6: fe80::2d0:f8ff:fe00:1 , subnet is fe80::/64
INET6: fec0:0:0:1::1 , subnet is fec0:0:0:1::/64
Joined group address(es):
ff01:1::1
ff02:1::1
ff02:1::2
ff02:1::1:ff00:1
MTU is 1500 bytes
ICMP error messages limited to one every 10 milliseconds
ICMP redirects are enabled
ND DAD is enabled, number of DAD attempts: 3
ND reachable time is 30000 milliseconds
ND advertised reachable time is 0 milliseconds
ND retransmit interval is 1000 milliseconds
ND advertised retransmit interval is 0 milliseconds
ND router advertisements are sent every 200 seconds<240--160>
ND router advertisements live for 1800 seconds

```

## 55.2.5

IPv6

2

| <b>configure terminal</b>                         |      |
|---|------|
| <b>interface</b> <i>interface-id</i>              |      |
| <b>ipv6 enable</b>                                | IPv6 |
| <b>ipv6 nd ns-interval</b><br><i>milliseconds</i> |      |

|  |  |
|--|--|
| <p><b>ipv6 nd reachable-time</b><br/><i>milliseconds</i></p>   | <p>RFC4861</p> <p>0.5    1.5</p>                     |
| <p><b>ipv6 nd prefix</b><br/><i>ipv6-prefix/prefix-length  </i><br/><b>default</b> [[<i>valid-lifetime</i><br/><i>preferred-lifetime</i>]   [<b>at</b><br/><i>valid-date preferred-date</i>]<br/>  <b>infinite</b>   <b>no-advertise</b>]]</p> | <p>(RA)</p>  |
| <p><b>ipv6 nd ra-lifetime</b><br/><i>seconds</i></p>   | <p>(RA)</p> <p>0</p>                                 |
| <p><b>ipv6 nd ra-interval</b><br/><i>seconds</i></p>   | <p>(RA)</p>  |
| <p><b>ipv6 nd</b><br/><b>managed-config-flag</b></p>   | <p>(RA)</p> <p>“managed address configuration” ,</p> |

|  |      |
|--|------|
|  |      |
| <b>show ipv6 interface</b> [ <i>interface-id</i> ] [ <i>ra-info</i> ]                            | IPv6 |
| <b>show ipv6 neighbors</b> [ <i>verbose</i> ]<br>[ <i>interface-id</i> ] [ <i>ipv6-address</i> ] |      |
| <b>show ipv6 route</b> [ <i>static</i> ] [ <i>local</i> ]<br>[ <i>connected</i> ]                | IPv6 |

## 1) IPv6

```
Ruijie# show ipv6 interface
interface vlan 1 is Down, ifindex: 2001
address(es):
Mac Address: 00:d0:f8:00:00:01
INET6: fe80::2d0:f8ff:fe00:1 , subnet is fe80::/64
INET6: fec0:1:1:1::1 , subnet is fec0:1:1:1::/64
Joined group address(es):
ff01:1::1
ff02:1::1
ff02:1::2
ff02:1::1:ff00:1
MTU is 1500 bytes
ICMP error messages limited to one every 10 milliseconds
ICMP redirects are enabled
ND DAD is enabled, number of DAD attempts: 1
ND reachable time is 30000 milliseconds
ND advertised reachable time is 0 milliseconds
ND retransmit interval is 1000 milliseconds
ND advertised retransmit interval is 0 milliseconds
ND router advertisements are sent every 200 seconds<240--160>
ND router advertisements live for 1800 seconds
```

## 2)

```
Ruijie# show ipv6 interface ra-info
vlan 1: DOWN
RA timer is stopped
waits: 0, initcount: 3
statistics: RA(out/in/inconsistent): 4/0/0, RS(input): 0
Link-layer address: 00:00:00:00:00:01
Physical MTU: 1500
```



# 56 IPv6

## 56.1

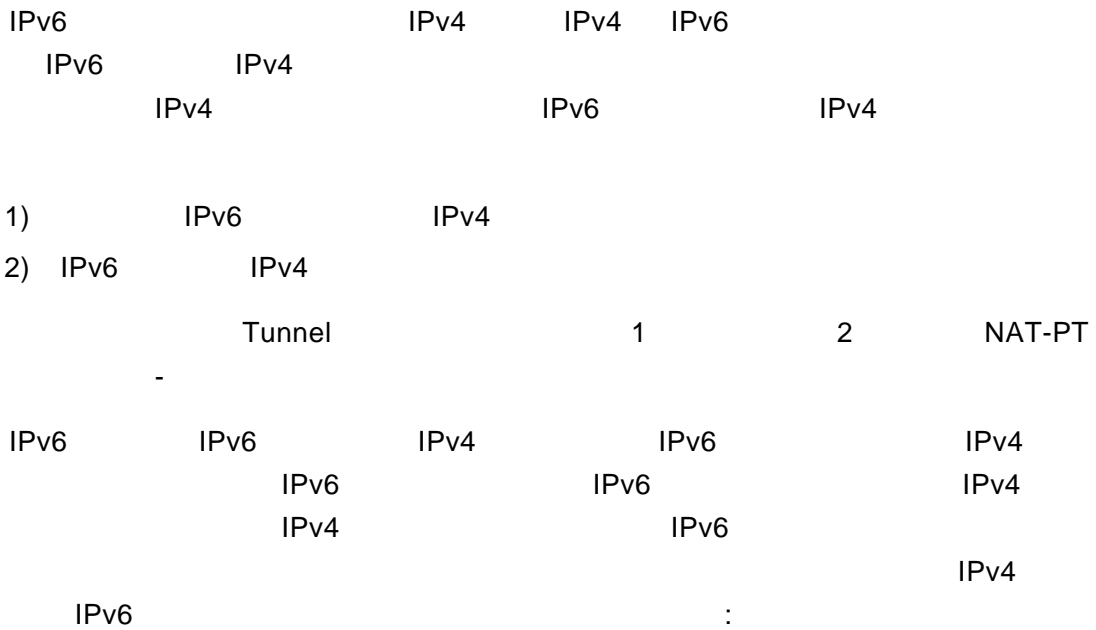

| Manually Config Tunnel                                  | RFC2893                      |
|---|------------------------------|
| automatic 6to4 Tunnel                                   | RFC3056                      |
| Intra-Site Automatic Tunnel Addressing Protocol(ISATAP) | draft-ietf-ngtrans-isatap-22 |

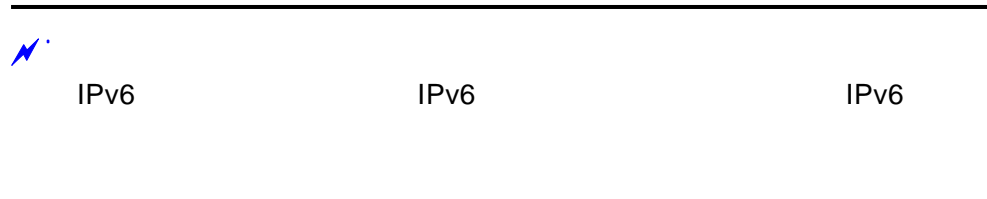



1

### 56.1.1 (IPv6 Manually Configured Tunnel)



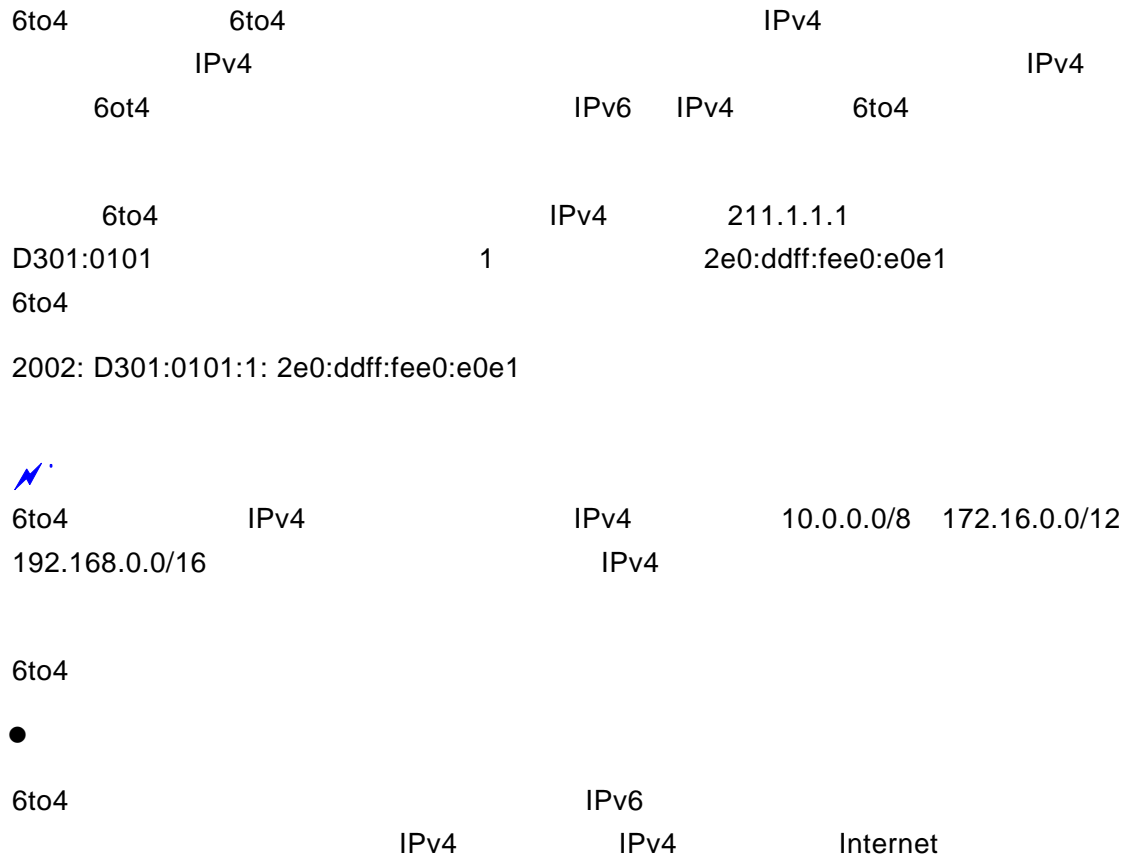

## ISATAP

```

config terminal
interface tunnel tunnel-num
tunnel mode ipv6ip
ipv6 enable
tunnel source {ip-address | type num}
tunnel destination ip-address
end
    
```

|  |      |              |      |
|--|------|--------------|------|
|  |      |              |      |
| <b>configure terminal</b>                              |      |              |      |
| <b>interface tunnel</b><br><i>tunnel-num</i>           |      |              |      |
| <b>tunnel mode</b><br><b>ipv6ip</b>                    |      |              |      |
| <b>ipv6 enable</b>                                     |      | IPv6<br>IPv6 | IPv6 |
| <b>tunnel source</b><br><i>{ip-address   type num}</i> |      | IPv4         |      |
| <b>tunnel destination</b><br><i>ip-address</i>         | IPv4 |              |      |
| <b>end</b>   |      |              |      |
| <b>copy running-config</b><br><b>startup-config</b>    |      |              |      |

“ IPv6 ”

### 56.2.2 6to4

```

6to4
6to4
6to4 IPv6
6to4 IPv4
6to4
    
```

---



### 56.2.3 ISATAP

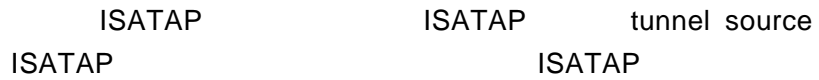
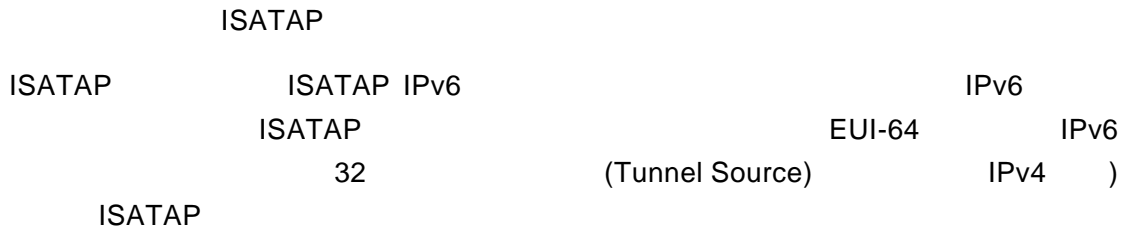

```

config terminal
interface tunnel tunnel-num
tunnel mode ipv6ip isatap
ipv6 address ipv6-prefix/prefix-length eui-64
tunnel source interface-type num
no ipv6 nd suppress-ra
end
    
```

|  |                                |
|--|--------------------------------|
| <b>configure terminal</b>  |                                |
| <b>interface tunnel</b><br><i>tunnel-num</i>                               |                                |
| <b>tunnel mode ipv6ip</b><br><b>isatap</b>                                 | ISATAP                         |
| <b>ipv6 address</b><br><i>ipv6-prefix/prefix-length</i><br><b>[eui-64]</b> | IPv6 ISATAP , eui-64<br>ISATAP |
| <b>tunnel source type num</b>  | ISATAP ,<br>IPv4               |
| <b>no ipv6 nd suppress-ra</b>  | ISATAP ,                       |







```
interface GigabitEthernet 2/1
no switchport
ip address 211.1.1.1 255.255.255.0

# IPv6
interface GigabitEthernet 2/2
no switchport
ipv6 address 2005::1/64
no ipv6 nd suppress-ra ( )

#
interface Tunnel 1
tunnel mode ipv6ip
ipv6 enable
tunnel source GigabitEthernet 2/1
tunnel destination 192.1.1.1

#
ipv6 route 2001::/64 tunnel 1
```

## 56.4.2 6to4



192.88.99.1

c058:6301



6to4

IPv4

6to4

2

IPv4

IPv4

**Enterprise Router**

```
# IPv4
interface GigabitEthernet 0/1
no switchport
ip address 61.154.22.41 255.255.255.128

# IPv6
interface GigabitEthernet 0/2
no switchport
ipv6 address 2002:3d9a:1629:1::1/64
no ipv6 nd suppress-ra

# 6to4
interface Tunnel 1
tunnel mode ipv6ip 6to4
ipv6 enable
tunnel source GigabitEthernet 0/1

#          tunt 0/1
```

```
#
ipv6 route 2002::/16 Tunnel 1
```

### 56.4.3 ISATAP

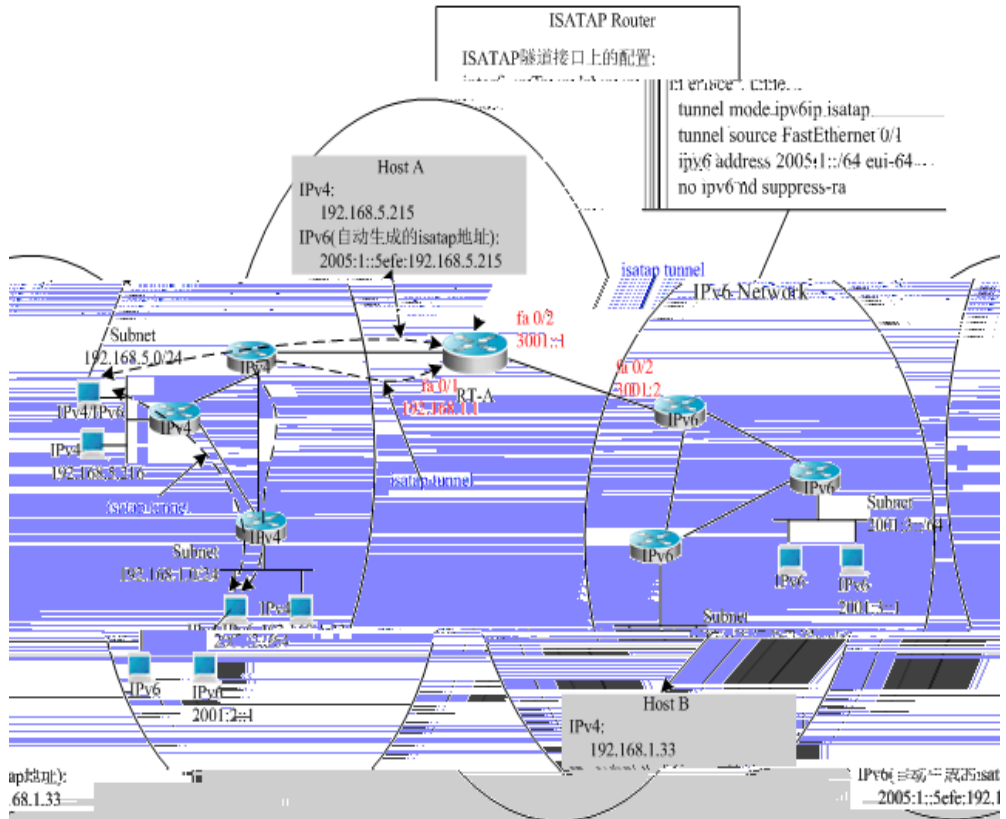

6

```

ISATAP          ISATAP          IPv4
IPv4/IPv6      ISATAP          ISATAP
2
●             ISATAP
ISATAP
●             ISATAP          IPv6
Host A  Host B          ISATAP Router  ISATAP Router
ISATAP
Host A  Host B  IPv6          ISATAP          Host A  Host B
IPv6          Host A          ISATAP          ISATAP
RT-A          RT-A  IPv6
ISATAP Router  RT-A
#             IPv4

```

```
interface GigabitEthernet 0/1
no switchport
ip address 192.168.1.1 255.255.255.0

# ISATAP
interface Tunnel 1
tunnel mode ipv6ip isatap
tunnel source GigabitEthernet 0/1
ipv6 address 2005:1::/64 eui-64
no ipv6 nd suppress-ra

# IPv6
interface GigabitEthernet 0/2
no switchport
ipv6 address 3001::1/64

# IPv6
ipv6 route 2001::/64 3001::2
```

#### 56.4.4 ISATAP 6to4

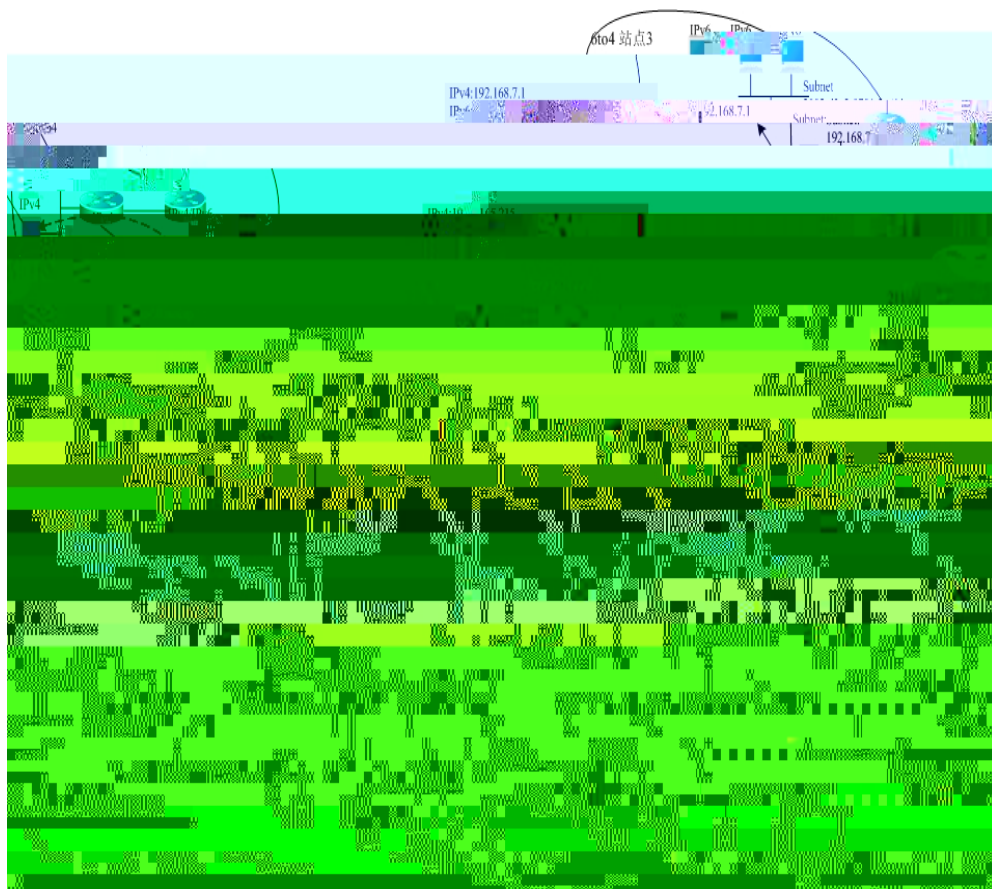



---

```

6to4      ISATAP      6to4      6to4
      6to4 relay router 6to4      Cernet      6to4
ISATAP      IPv4      IPv6      ISATAP      IPv6

```

---



---



```

IP      6to4 Relay
      IP      6to4 Relay
6to4 Relay

```

---

6to4

RT-A

```

#      Internet
interface GigabitEthernet 0/1
no switchport
ip address 211.162.1.1 255.255.255.0

#      IPv4
interface GigabitEthernet 0/1
no switchport
ip address 192.168.0.1 255.255.255.0

#      ISATAP
interface Tunnel 1
tunnel mode ipv6ip isatap
tunnel source GigabitEthernet 0/1
ipv6 address 2002:d3a2:0101:1::/64 eui-64
no ipv6 nd suppress-ra

#      IPv6      1
interface GigabitEthernet 0/2
no switchport
2002:d3a2:0101:10::1/64

#      IPv6      2
interface GigabitEthernet 0/2

```

```
no switchport
2002:d3a2:0101:20::1/64

#      6to4
interface Tunnel 2
tunnel mode ipv6ip 6to4
ipv6 enable
tunnel source GigabitEthernet 0/1

#      6to4
ipv6 route 2002::/16 Tunnel 2

#      6to4      RT-D      ,      Cernet
ipv6 route ::/0 2002:d3a2::0901::1

RT-B

#      Internet
interface GigabitEthernet 0/1
no switchport
ip address 211.162.5.1 255.255.255.0

#      IPv4      1
interface GigabitEthernet 0/1
no switchport
ip address 192.168.10.1 255.255.255.0

#      IPv4      2
interface GigabitEthernet 0/2
no switchport
ip address 192.168.20.1 255.255.255.0

#      ISATAP
interface Tunnel 1
tunnel mode ipv6ip isatap
tunnel source GigabitEthernet 0/1
ipv6 address 2002:d3a2:0501:1::/64 eui-64
no ipv6 nd suppress-ra

#      6to4
interface Tunnel 2
tunnel mode ipv6ip 6to4
ipv6 enable
tunnel source GigabitEthernet 0/1

#      6to4
ipv6 route 2002::/16 Tunnel 2
```

```
#      6to4      RT-D      ,      Cernet
ipv6 route ::/0 2002:d3a2::0901::1
```

**RT-C**

```
#      Internet
interface GigabitEthernet 0/1
no switchport
ip address 211.162.7.1 255.255.255.0
```

```
#      IPv4
interface GigabitEthernet 0/1
no switchport
ip address 192.168.0.1 255.255.255.0
```

```
#      ISATAP
interface Tunnel 1
tunnel mode ipv6ip isatap
tunnel source GigabitEthernet 0/1
ipv6 address 2002:d3a2:0701:1::/64 eui-64
no ipv6 nd suppress-ra
```

```
#      IPv6
interface GigabitEthernet 0/2
no switchport
2002:d3a2:0701:10::1/64
```

```
#      6to4
interface Tunnel 2
tunnel mode ipv6ip 6to4
ipv6 enable
tunnel source GigabitEthernet 0/1
```

```
#      6to4
ipv6 route 2002::/16 Tunnel 2
```

```
#      6to4      RT-D      ,      Cernet
ipv6 route ::/0 2002:d3a2::0901::1
```

**RT-D(6to4 Relay)**

```
#      Internet
interface GigabitEthernet 0/1
no switchport
ip address 211.162.9.1 255.255.255.0
```

```
#      IPv6
interface GigabitEthernet 0/1
```

